

MAGNUM[®] MHC1100-316 Slab Lift Cap

Allowable Capacity - 16 Tons Compression

3-Inch I.D. Collar with 16.00" Channel and Lifting Bolt Assembly

Fits MH313, MH313R, MH325, MH325R Magnum[®] Helical Piles



Description

Magnum MHC1100-3 slab lift cap has 32 tons ultimate capacity, 16 tons working capacity in compression. The slab lift cap consists of a collar tube with bolt hole for connection to Magnum helical piles and a channel and lifting bolt for insertion under existing slabs. The slab lift cap is designed in accordance with ICC-ES document AC358 as well as IBC, ACI, and AISC codes. Spacing and placement of the lifting caps under the existing slab varies by project and is the responsibility of registered design professional including maximum span of slab.

SPECIFICATIONS	
Collar Tube	0.25 in. x 3 in. I.D. ASTM A513 GR65+
End Effector	6.00" x 3.50" x 0.375" – 16.00" Long Channel and a 1.13" Lifting Bolt
Pile Connection	Direct Bearing on Pile Shaft
Surface Coating	Galvanized per ASTM A153/A123 (G), Bare Steel (NG), or Epoxy Coated per ICC-ES AC228 (EP)
Compatibility	MH313, MH313R, MH325, and MH325R

CAP CAPACITY	
Ultimate Compression / Tension	32 Tons / 32 Tons
Allowable Compression / Tension	16 Tons / 16 Tons

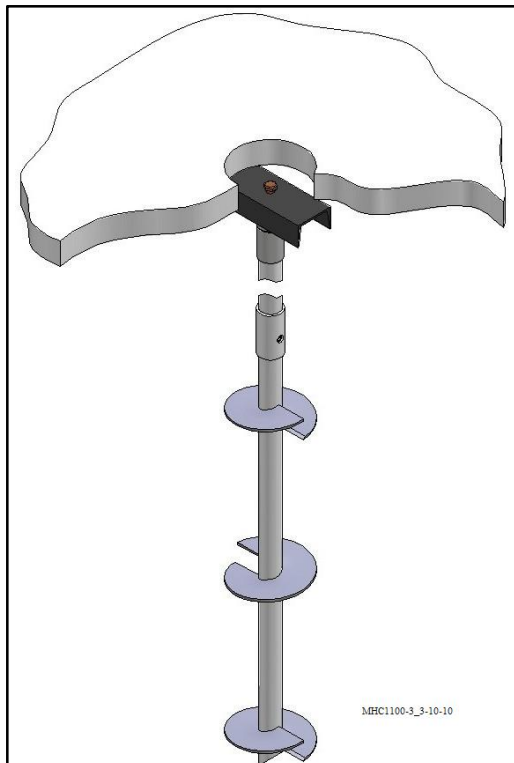
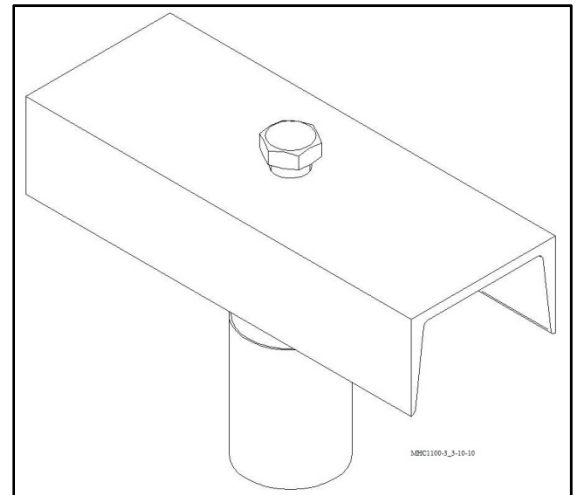

Installation Notes:

Core a hole through the slab slightly larger than the largest helix. Excavate a void large enough to facilitate channel installation. Install a Magnum Helical Pile to the correct depth, torque, and capacity. Cut-off the pile shaft at the proper elevation. Place the pile cap over the shaft. Place the channel under the slab with lifting bolt in place. Tighten the lifting bolt to raise the slab elevation as needed. Fill the void under the slab and core hole with cement grout.

All Magnum Steel & Products Made in U.S.A.

Magnum Piering, Inc.

6082 Schumacher Park Dr.
West Chester, OH 45069
800-822-7437
www.magnumpiering.com

© Copyright 2010 Magnum Piering, Inc. All Rights Reserved.
U.S. Patents 6,058,662 and 5,234,287; Other Patents Pending.