

MAGNUM® MHC1300-3E1212BR Bearing Plate Cap

Allowable Capacity 25 Tons Compression / 25 Tons Tension

3-Inch I.D. Collar with 12"x12"x3/4" Bearing Plate

Fits MH313, MH313R, MH325, and MH325R Magnum® Helical Piles



Description

Magnum MHC1300-3E1212BR bearing plate cap has 50 tons ultimate capacity, 25 tons working capacity in compression and tension. The bearing plate cap consists of a collar tube with bolt hole for connection to Magnum helical piles and 12"x12"x3/4" plate for embedment in cast-in-place reinforced concrete or attachment to a steel beam. The bearing plate cap is designed in accordance with ICC-ES document AC358 as well as IBC, ACI, and AISC codes. Application of the cap varies by project and is the responsibility of registered design professional including beam attachment, minimum embedment for two-way and one-way punching shear, reinforcement of concrete, and pile spacing as applicable.

SPECIFICATIONS	
Collar Tube	0.3 in. x 3 in. I.D. ASTM A513 GR65+
End Effector	12"x12"x3/4" Steel Bearing Plate
Pile Connection	(2) 1" SAE Grade 5 / ASTM A325 Bolts
Surface Coating	Galvanized per ASTM A153/A123 (G), Bare Steel (NG), or Epoxy Coated per ICC-ES AC228 (EP)
Compatibility	MH313, MH313R, MH325, and MH325R

CAP CAPACITY	
Ultimate Compression / Tension	50 Tons / 50 Tons
Allowable Compression / Tension	25 Tons / 25 Tons

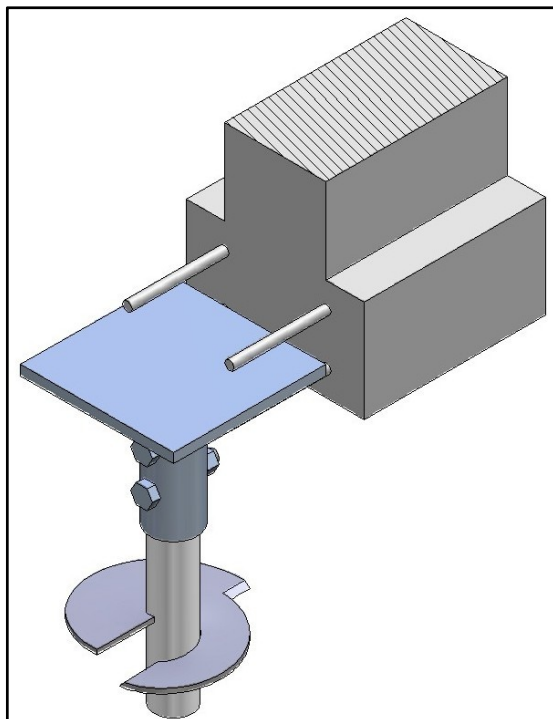
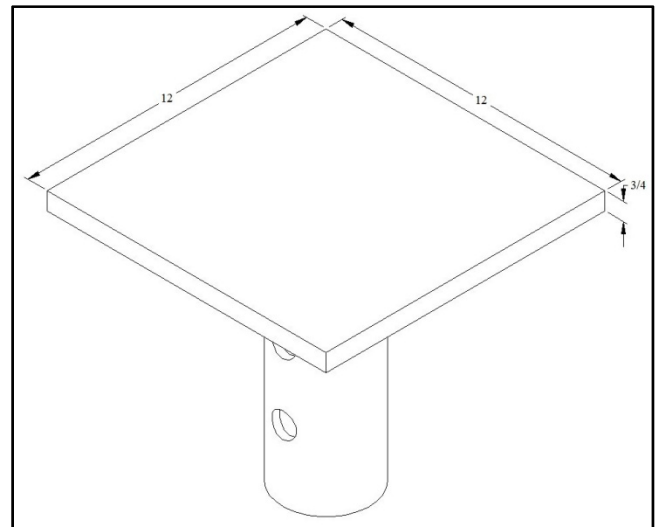

Installation Notes:

After installation of a Magnum Helical Pile to the correct depth, torque, and capacity, cut-off the pile shaft at the proper elevation. Drill two 17/16" holes using Magnum drill template. Place the pile cap over the shaft and secure with two 1" bolts. Snug tighten nuts. Place reinforced concrete over cap or place beam on cap and weld per project specifications.

All Magnum Steel & Products Made in U.S.A.

Magnum Piering, Inc.

6082 Schumacher Park Dr.
West Chester, OH 45069
800-822-7437
www.magnumpiering.com

© Copyright 2010 Magnum Piering, Inc. All Rights Reserved.
U.S. Patents 6,058,662 and 5,234,287; Other Patents Pending.