

MAGNUM[®] MHC1300-3J55B Bearing Plate Cap

Allowable Capacity 25 Tons Compression / 16 Tons Tension

3-Inch I.D. Collar with 5.00" x 5.00" x 0.50" Bearing Plate

Fits MH313, MH313R, MH325 Magnum[®] Helical Piles



Description

Magnum MHC1300-3A55B bearing plate cap has 50 tons ultimate capacity, 25 tons working capacity in compression and 32 tons ultimate capacity, 16 tons working capacity in tension. The bearing plate cap consists of a collar tube with bolt hole for connection to Magnum helical piles and 5.00" x 5.00" x 0.25" plate for embedment in cast-in-place reinforced concrete. The bearing plate cap is designed in accordance with ICC-ES document AC358 as well as IBC, ACI, and AISC codes. Application of the cap varies by project and is the responsibility of registered design professional including minimum embedment for two-way and one-way punching shear, reinforcement of concrete, and pile spacing.

SPECIFICATIONS	
Collar Tube	0.25 in. x 3.00 in. I.D. ASTM A513 GR65+
End Effector	5.00" x 5.00" x 0.25" Steel Bearing Plate
Pile Connection	(1) 0.88" SAE Grade 5 / ASTM A325 Bolt
Surface Coating	Galvanized per ASTM A153/A123 (G), Bare Steel (NG), or Epoxy Coated per ICC-ES AC228 (EP)
Compatibility	MH313, MH313R, MH325

CAP CAPACITY	
Ultimate Compression / Tension	50 Tons / 32 Tons
Allowable Compression / Tension	25 Tons / 16 Tons

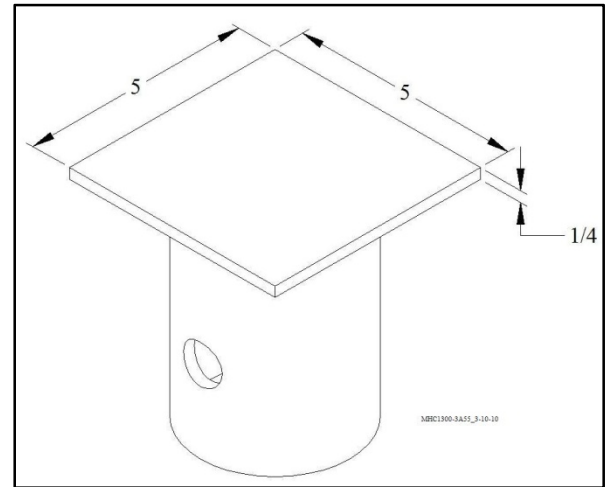

Note: Cap capacity takes into account strength of collar, end effector, and pile connection. Capacity may be limited by the helical pile itself, bearing/pullout capacity of soil, or strength of the structure to which the cap is attached, whichever is less.

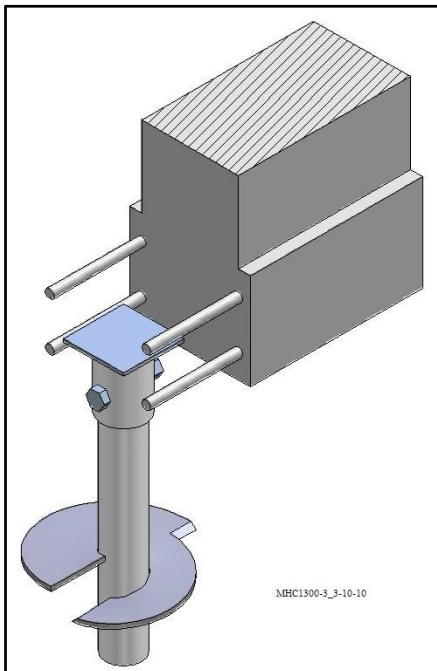

Installation Notes:

After installation of a Magnum Helical Pile to the correct depth, torque, and capacity, cut-off the pile shaft at the proper elevation. Drill 0.94" hole using Magnum drill template. Place the pile cap over the shaft and secure with 0.88" bolt. Snug tighten nut. Place reinforcing steel as required for the project and cast concrete over and around the pile cap.

All Magnum Steel & Products Made in U.S.A.

Magnum Piering, Inc.

6082 Schumacher Park Dr.
West Chester, OH 45069
800-822-7437
www.magnumpiering.com

© Copyright 2010 Magnum Piering, Inc. All Rights Reserved.
U.S. Patents 6,058,662 and 5,234,287; Other Patents Pending.