

# MAGNUM® MHC1420-3N1212BR Tilted Plate Cap

## Allowable Capacity 25 Tons Compression / 25 Tons Tension

3-Inch I.D. Collar with 12.00" x 12.00" x 0.75" Bearing Plate Tilted 20 Degrees  
Fits MH325R Magnum® Helical Piles



### Description

Magnum MHC1420-3N1212BR bearing plate cap has 50 tons ultimate capacity, 25 tons working capacity in compression and tension. The bearing plate cap consists of a collar tube with bolt holes for connection to Magnum helical piles and 12.00" x 12.00" x 0.75" plate battered 20 degrees for attachment to a steel beam. The bearing plate cap is designed in accordance with ICC-ES document AC358 as well as IBC, ACI, and AISC codes. Application of the cap varies by project and is the responsibility of registered design professional including beam attachment, beam shear, beam span, web stiffening, bracing, and pile spacing as applicable.

SPECIFICATIONS	
Collar Tube	0.31 in. x 3.00 in. I.D. ASTM A513 GR65+
End Effector	12.00" x 12.00" x 0.75" Steel Bearing Plate Tilted 20 Degrees
Pile Connection	(2) 1.00" SAE Grade 5 / ASTM A325 Bolts
Surface Coating	Galvanized per ASTM A153/A123 (G), Bare Steel (NG), or Epoxy Coated per ICC-ES AC228 (EP)
Compatibility	MH325R

CAP CAPACITY	
Ultimate Compression / Tension	50 Tons / 50 Tons
Allowable Compression / Tension	25 Tons / 25 Tons

Note: Cap capacity takes into account strength of collar, end effector, and pile connection. Capacity may be limited by the helical pile itself, bearing/pullout capacity of soil, or strength of the structure to which the cap is attached, whichever is less.

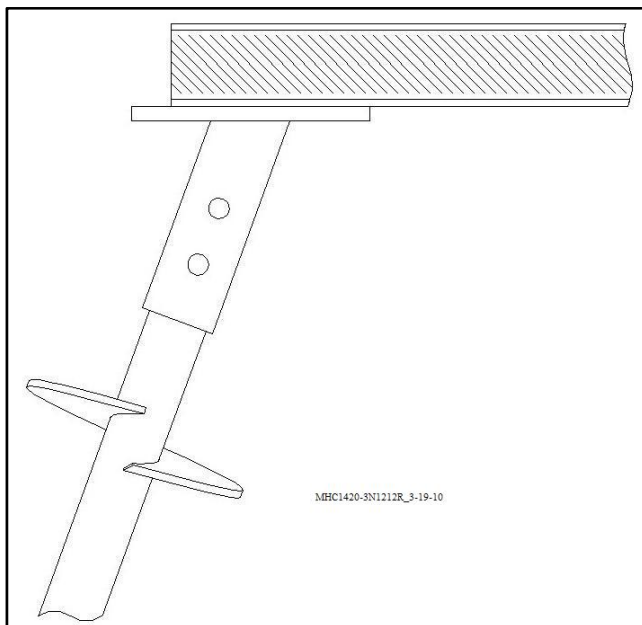
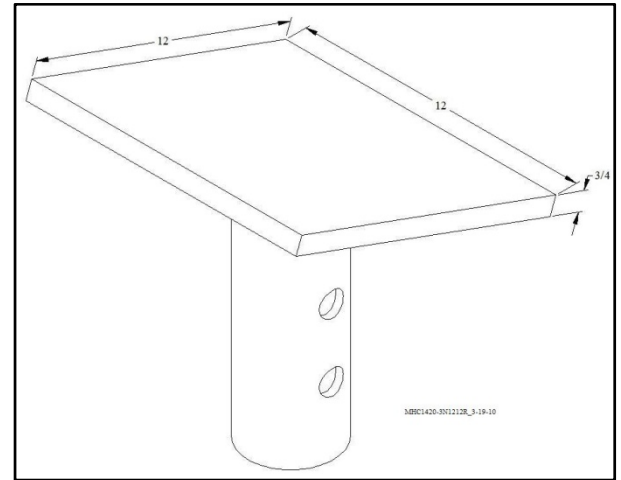

### Installation Notes:

After installation of a Magnum Helical Pile to the correct depth, torque, and capacity, cut-off the pile shaft at the proper elevation. For Bolted "B" application, drill two 1.06" holes using Magnum drill template. Place the pile cap over the shaft and secure with two 1.00" bolts. Snug tighten nuts. For Welded "W" application, plug weld cap in place through manufactured drill holes. Remove surface coating from plug weld areas. Place steel beam on cap and weld per project specifications.

*All Magnum Steel & Products Made in U.S.A.*

### Magnum Piering, Inc.

6082 Schumacher Park Dr.  
West Chester, OH 45069  
800-822-7437  
www.magnumpiering.com

© Copyright 2010 Magnum Piering, Inc. All Rights Reserved.  
U.S. Patents 6,058,662 and 5,234,287; Other Patents Pending.