

Table of Contents

Introduction

ISO 9001.....	3
Quality Materials	4

Helical Piles

Number Specification Legend.....	8
Helical Pile Specifications.....	9
Helical Pile Cut Sheets	12
Transition Pile Cut Sheets	44
Helical Pile Sizing Guides.....	47
Shaft Buckling Capacity.....	59
Corrosion and Life Expectancy.....	61

Displacement Piles

Number Specification Legend.....	68
Installation Examples.....	69
Propulsion Grout Pile Cut Sheets	70
Post Grout Piles.....	75

Push Piers & Jacked Piles

Number Specification Legend.....	78
Ratings and Specifications	79
Sizing Guide	81
Push Piers	82
Jacked Pile Couplings	90

Steel Pile Caps

Number Specification Legends.....	94
Cap Specifications.....	97
Anchor Cap Cut Sheets.....	102
Concrete Cap Cut Sheets.....	118
Rebar Cap Cut Sheets.....	155
Direct Connect Cap Cut Sheets.....	165
Pipe Support Cap Cut Sheets.....	181
Cap Application Guides	186

Foundation Brackets

Number Specification Legend.....	190
Bracket Ratings & Specifications.....	191
Bracket Cut Sheets.....	195
Lifting Assembly.....	203
Lifting Assembly.....	207

Boardwalk & Wood Support Brackets

Wood Cap Cut Sheets.....	218
Boardwalk K-Bracing System.....	231
Boardwalk H-Bracing System.....	232



Table of Contents (cont.)

Helical Post Bases

Number Specification Legend.....	236
Ratings and Specifications	237
Cut Sheets	239

Other Foundation Products

3.0" Crawl Space Support Post	250
Basement Reinforcing Beams	251
Full Displacement Tip	252
Shear Lock.....	253
Ratings and Specifications	257
Helical Bollards	258

Push Pier Rams & Accessories

Ram Kit Specifications.....	262
-----------------------------	-----

Tooling

Drive Adaptors	270
Adapter Order Form.....	271
Hydraulic Control	273
Torque Motor Skid.....	274

Micropile & Thread Bar Brackets

Ratings and Specifications	278
Micropile Bracket Cut Sheets	279
All Thread Bar Number Specification Legend.....	282
Thread Bar Ratings and Specifications	283
Accessory Number Specification Legend	284
Accessory Ratings and Specifications.....	285

Earth Anchor Systems

Soil Nails.....	290
Deadman Plate Anchor.....	291

Introduction





About Magnum Piering

MAGNUM® Piering launched its flagship product line, the MAGNUM® Hydraulic Push Pier System, in 1981. This established the company as one of the very first foundation repair systems manufacturers in United States and was the beginning of over 40 years of unparalleled performance. Now, with tens of thousands of successful projects, this system is recognized by contractors across the country as the most efficient and reliable foundation underpinning system on the market. In 2001 MAGNUM® developed and introduced the 3-inch MAGNUM® Helical Pile product line. Building on this found success, MAGNUM® expanded the helical product line to include round corner square shaft helical piles, grouted helical piles, as well as round shaft helical pile diameters from 2.875 – 24-inch and everything in between. These products provide our clients with the capabilities of achieving capacities in excess of 100 tons. MAGNUM® Helical Piles are now specified by engineers for a multitude of different applications including but not limited to: bridges, boardwalks, homes, metal buildings, solar panels, wind turbines, power transmission towers, gas compressors, oil and gas equipment / pipelines, and multi-story buildings.

Timeline

- 1981 We launch our first product
- 1999 Relocated to West Chester, OH
- 2001 Launch of our Helical Pile product line
- 2008 We build a 40,000 sq/ft facility
- 2015 We purchase and begin renovating a new facility
- 2016 We move production to state of the art, 100,000+ sq/ft headquarters
- 2022 We continued expansion of manufacturing on 7-acre property



Quality Manufacturing

MAGNUM® operates a state of the art 100,000+ sq/ft manufacturing facility boasting overhead cranes, robotic welding, a CNC laser cutting system, CNC drilling and a myriad of additional equipment. MAGNUM® can provide contractors a completely custom helical pile, designed specifically for that job, with quick turnaround times. In addition, MAGNUM® has made significant investments in product testing (ICC-ES Evaluation Report) and quality assurance programs (ISO 9001 Accreditation) designed to improve and extend the company's commitment to supplying the best products in the industry. These accreditations position MAGNUM® Piering as one of the leading companies in our industry and ensure continued growth and success for customers and employees for many years to come.

ICC-ES Evaluation

MAGNUM® Piering attests that all of its helical pile products have been designed to meet or exceed ICC-ES AC358 criteria. MAGNUM® uses both an internal quality assurance testing program and an outside, independent IAS accredited laboratory to conduct product testing in accordance with AC358. ICC-ES evaluation under AC358 criteria means that MAGNUM®'s products meet or exceed the most up-to-date industry standards, which ensures you a high level of assurance that the product will perform as designed.



ICC-ES ESR-2997 certifies capacities of MAGNUM®'s MH325B, MH325BR, MS150 helical piles in accordance with AC358. Also included in this report are the before mentioned product's bearing plate caps, tie-back caps, as well as foundation repair brackets. Other product sizes and types are accredited by AC358 engineering calculations under responsible charge of a licensed PE. MAGNUM® Piering representatives served as lead consultant and chair of the Ad Hoc Committee of Helical Foundation Manufacturers that drafted AC358. MAGNUM® personnel are leading advocates of ICC-ES evaluation and leaders in quality systems. In addition, ICC-ES ESR-4317 certifies the capacities of the following Magnum Push Pier Products: MP325, MP1001-3, MP1002-3, and the MP1005-3.

ISO 9001 Certification

In 2008, MAGNUM® underwent its first ISO 9001 audit. Since then, we conduct on going internal audits as well as submit to yearly audits from a third-party auditor. This ensures we continue to meet or exceed ISO 9001 standards.

Scope of Registration:

Steel Fabrication including, CAD Design, Laser Cutting, Bending, Welding, Robotic Welding, Machining and Fabrication of Helical Piles, Helical Anchors, Resistance Pier Products for New Construction Deep Foundations, Remedial Foundation and Repair Applications.

You can view and download a copy of our certification here:
<https://www.magnumpiering.com/products/iso-9001-certificate/>



Quality Policy

ISO 9001– The Global Standard for Quality Assurance Benefits & Assurance for MAGNUM[®] Piering, Inc. Customers

- Continual improvement, striving for complete customer satisfaction
- Efficiency and productivity
- Minimalizing risks in product liability
- Reduced inspection and testing costs
- Cost savings through reduction of manufacturing errors
- Consistency of service and product performance
- Transparency through clearly defined processes
- Continuous process and structural improvements
- Quick identification / correction of weaknesses
- Securing a competitive edge with an internationally recognized certification

MAGNUM[®] Piering, Inc. is the recognized leader in providing high quality, competitively priced foundation systems and services. We are committed to meeting all applicable requirements and exceeding our customers' needs through focused efforts on continuous improvement and customer service.





Quality Materials

MAGNUM® Piering manufactures its helical pile and steel push pier products from new, high-quality, American made steel. Material certificates are available for all of our steel shaft and plate materials.

Better Steel – Better Piles

All MAGNUM® 3.00" diameter helical pile and push pier products and many of our other products are manufactured from ASTM steel tubing. This premium steel tubing has higher carbon and alloy content, which means greater strength. ASTM is the common designation for mechanical tubing, which is used in applications that require closer tolerances and when the strength to weight ratio is important. This type of tubing is used in applications where dimensions and quality are critical for products like hydraulic cylinders and shock absorbers. Statistical process control is used to reduce variations in tube dimensions and the welding process.

Patented Dual Cutting Edge Helix / Moment Balance

MAGNUM®'s patented dual-cutting-edge (DCE) helix out performs standard circular helical bearing plates in difficult soil and bedrock conditions. The DCE helix offers a truer installation, tracks better, cuts through difficult soils such as gravel, construction debris, or trash, and will penetrate medium hard bedrock formations with an SPT blow count up to 100 to 150 blows per foot, or 50/6 to 50/4. The DCE helix gives you a better chance of getting through tough soil and bedrock situations without the need for pre-drilling. This patent also includes moment balance of the helix bearing plates. This positions the opening of the helix on alternating sides of the shaft while ensuring that helix follows the same path when advancing in the soil as the previous one. Doing this provides less "walking" of the pile and allows the pile to be installed with extreme accuracy.

High Strength Round Shafts

MAGNUM® offers round high-strength, structural steel tube shafts with rigid couplings. Round shafts generally have greater torsional capacity, buckling capacity, and greater lateral capacity than square or rectangle shafts. This means that helical piles and push piers can be used in new construction for structures with lateral, wind and seismic loads. It also means that you can compute buckling conventionally and you can use MAGNUM® helical piles and push piers in soft soils reducing the need for grout around the shaft.

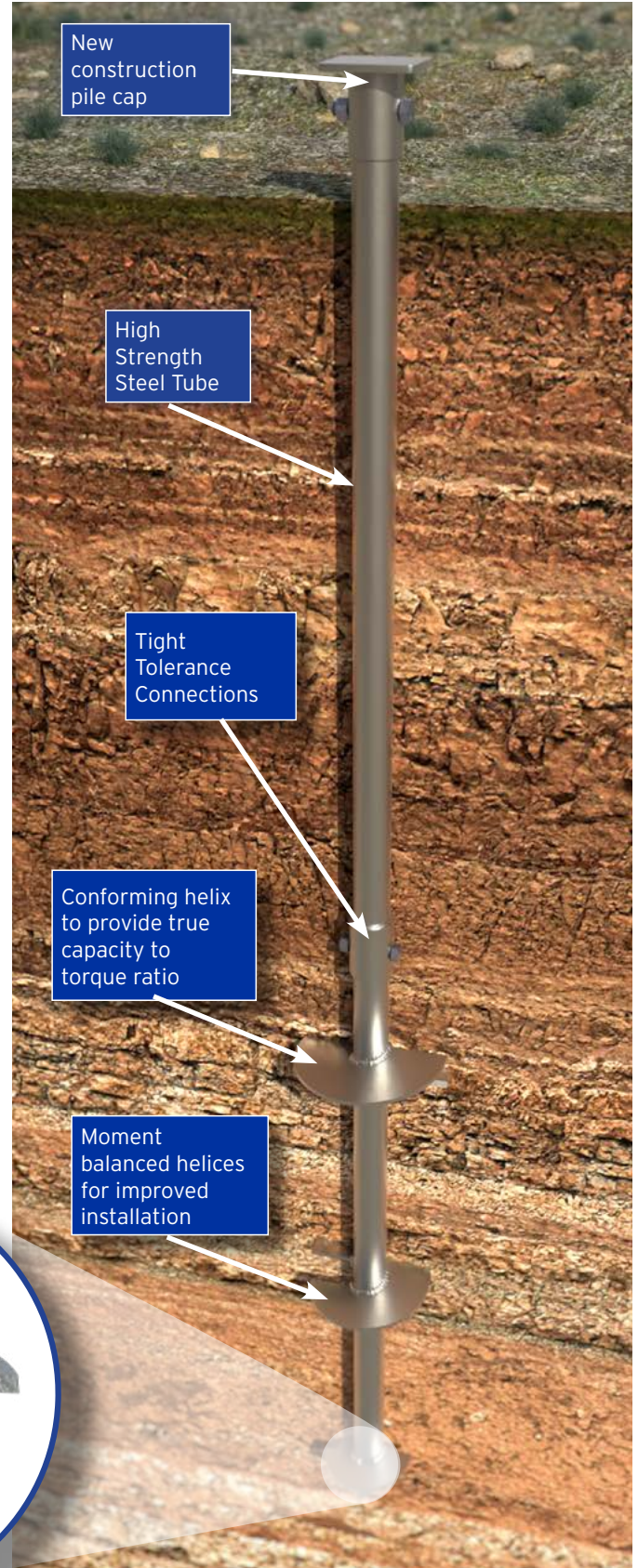

Dual Cutting Edge

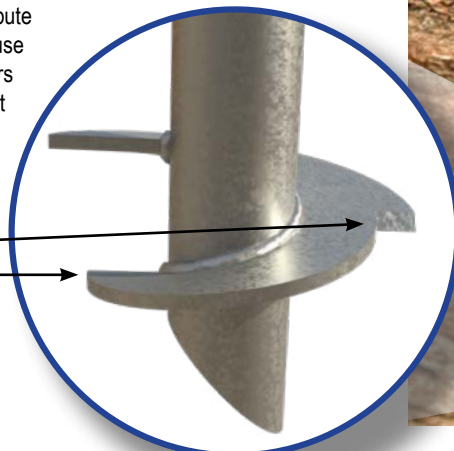



Technical Support

MAGNUM® Piering understands the importance of providing excellent technical support. MAGNUM® strives to provide the most accessible, responsive, and knowledgeable technical and engineering support in the industry.

Experience

Since its founding in 1981, MAGNUM® Piering, Inc. has gained the expertise that other companies just don't have. We have provided engineering support, foundation products, installation observation and load testing for a variety of diverse projects. Our projects range from residential tract homes to high-rise commercial developments, industrial gas compressors, power transmission, deep excavation shoring, membrane tension structures and NASA launch pads. Our experience has resulted in an extensive and encompassing product line to meet the diverse needs of our clients.

Expertise

Our director of engineering, Dr. Howard Perko, authored the only book currently available on helical pile installation and design, issued by a world-renowned publisher, John Wiley & Sons. Dr. Perko also authored helical pile additions to the 2009 IBC, and he was an expert consultant on writing of the NYC DOB code on helical piles. Having Magnum's experts on your team will give you piece of mind.

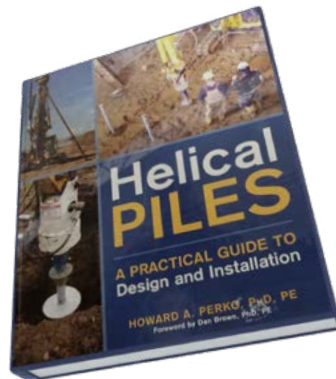

Engineering Services

MAGNUM® Piering has partnered with MAGNUM® Geo-Solutions, LLC to provide assistance in engineering projects involving MAGNUM® Piering, Inc. products. MAGNUM® Geo-Solutions, LLC currently operates an engineering office in Loveland, Colorado. Here a team of engineers is standing by ready and willing to help with project submittals and design-build support for foundation, shoring, underpinning, repair, and earth retention projects. MAGNUM® Geo-Solutions, LLC's engineers are licensed in 40 U.S. states. We also frequently provide support and advice under a peer review system throughout the World. Customers receive a separate contract and are charged by MAGNUM® Geo-Solutions, LLC for engineering services provided.

CAD Design Services

Our in-house CAD design department and engineers have the talent to design specialty foundation products to suit specific project requirements and the needs of our customers. Simply put in a request for quote for a specific foundation product, custom cap, or drive tool, and MAGNUM®'s CAD department in conjunction with manufacturing and sales will turn-around a drawing and quote for your approval in typically 24 to 48 hours.



Order Processing

In 2010, MAGNUM® Piering, Inc. announced the consolidation of sales and engineering support and the expansion of its customer service department. A team of support specialists has been assembled to better serve your needs. Each member of the support team is equipped and authorized to answer questions, suggest product sizes, and prepare material quotes upon your request. Below is an organizational chart for the company structure. The support team is standing by to help answer questions and meet your needs. Simply call or e-mail a team member for help today!

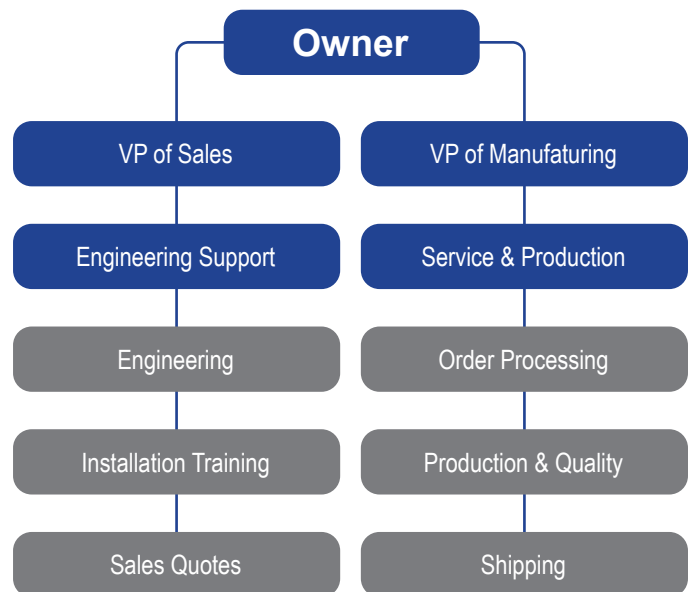

Helical Piles

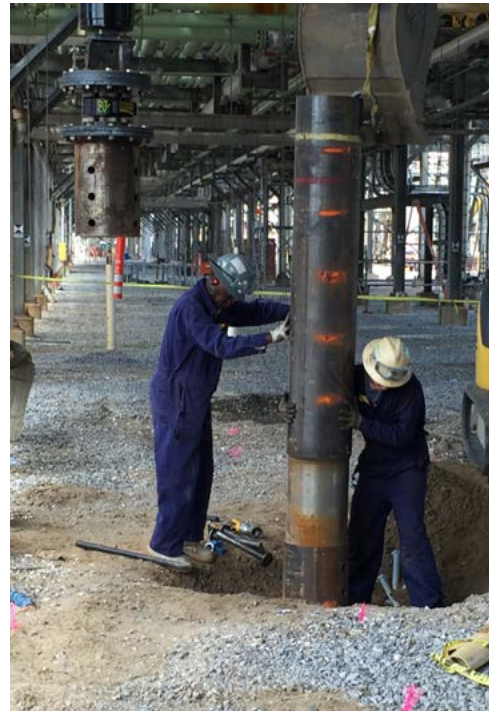

Helical Pile Number Specification Legend

Example

The MAGNUM® Helical Pile product number below, MHL434U10L12S14S6G, is for a Lead with 4.5" diameter shaft, a 0.337" wall thickness, 80ksi shaft material, 10 ft. long with (2) 0.50" Single Edge Helices 12 and 14 inches in diameter with a 6" pitch, and the surface preparation is Galvanized.

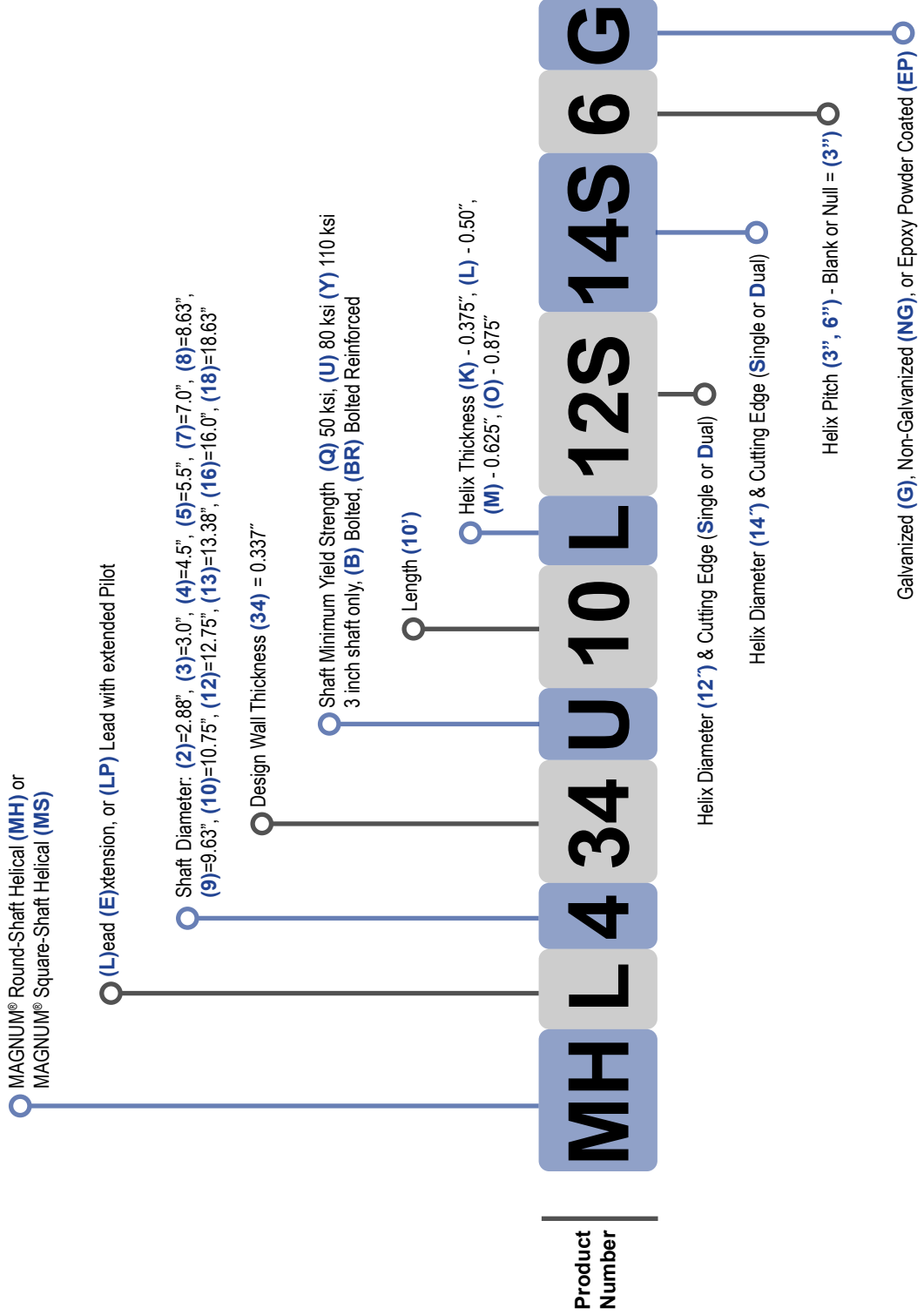

Helical Pile Specifications

System Ratings & Specifications

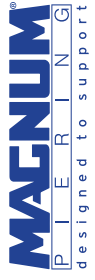

Product	Shaft Specifications					Structural Capacity (Tension & Comp)		Maximum Torque (ft-lbs)	Capacity to Torque Ratio (ft ⁻²)	Geotechnical Capacity (Tension & Comp)		Helix Specifications		Surface Coating	Standard Section Lengths (ft)
	Design Wall Gauge (in)	Outside Diameter (in)	Approx Weight (pif)	Min. Yield Strength (ksi)	Min. Tensile Strength (ksi)	Ultimate (tons)	Allowable (tons)			Ultimate (tons)	Allowable (tons)	Diameters (available in standard & dual cutting edge) (in)	Design Gauge (in)		
MS150B	1-1/2 SQ		7.7	90	100	36	18	7,000	10	36	18	8, 10, 12 & 14	0.375	NG, G, EP	3, 5, 7
MS175B	1-3/4 SQ		10.4	90	100	58	29	10,500	10	52	26	8, 10, 12 & 14	0.5	NG, G, EP	3, 5, 7
MH2325U	0.25	2-3/8	5.7	80	90	34	20	5,700	10	29	14	8, 10, 12 & 14	0.375	NG, G, EP	3, 6, 10
MH222U	0.22	2-7/8	6.2	80	90	41	21	7,800	9	35	17.5	8, 10, 12, 14 & 16	0.375	NG, G, EP	3, 6, 10, 15
MH227U	0.276	2-7/8	7.7	80	90	51	25	9,400	9	42	21	8, 10, 12, 14 & 16	0.375	NG, G, EP	3, 6, 10, 15
MH227U-6	0.276	2-7/8	7.7	80	90	51	25	9,400	7.3	34	17	8, 10, 12, 14 & 16	0.375	NG, G, EP	3, 6, 10, 15
MH313B	0.125	3	3.8	65	80	18	9	4,500	8	18	9	8, 10, 12, 14 & 16	0.375	NG, G, EP	3, 6, 10, 15
MH313BR	0.125	3	3.8	65	80	29	15	5,900	8	24	12	8, 10, 12, 14 & 16	0.375	NG, G, EP	3, 6, 10, 15
MH325B	0.27	3	7.3	65	80	33	16.5	8,300	8	33	16.5	8, 10, 12, 14 & 16	0.375	NG, G, EP	3, 6, 10, 15
MH325BR	0.27	3	7.3	65	80	54	27	12,500	8	50	25	8, 10, 12, 14 & 16	0.375	NG, G, EP	3, 6, 10, 15
MH325BR-6	0.27	3	7.3	65	80	54	27	12,500	7	44	22	10, 12, 14 & 16	0.375	NG, G, EP	3, 6, 10, 15
MH3521U	0.21	3-1/2	7.4	80	90	42	21	11,400	7	40	20	10, 12, 14 & 16	0.375	NG, G, EP	3, 6, 10, 15
MH3530U	0.3	3-1/2	10.3	80	90	48	24	13,700	7	48	24	10, 12, 14, 16, 20 & 24	0.375	NG, G, EP	3, 6, 10, 15
MH429U	0.29	4-1/2	13	80	90	91	45	26,200	5.7	75	37	10, 12, 14, 16, 20 & 24	0.5	NG, G, EP	5, 7.5, 10, 15

Helical Pile Specifications

System Ratings & Specifications



Product	Shaft Specifications					Structural Capacity (Tension & Comp)		Maximum Torque (ft-lbs)	Capacity to Torque Ratio (ft ⁻¹)	Geotechnical Capacity (Tension & Comp)		Helix Specifications		Surface Coating	Standard Section Lengths (ft)
	Design Wall Gauge (in)	Outside Diameter (in)	Approx Weight (plf)	Min. Yield Strength (ksi)	Min. Tensile Strength (ksi)	Ultimate (tons)	Allowable (tons)			Ultimate (tons)	Allowable (tons)	Diameters (available in standard & dual cutting edge) (in)	Design Gauge (in)		
MH429Y	0.29	4-1/2	13	110	120	120	60	34,900	5.7	99	50	10, 12, 14, 16, 20 & 24	0.5	NG, G, EP	5, 7.5, 10, 15
MH434U	0.34	4-1/2	15	80	90	120	60	29,700	5.7	85	42.5	10, 12, 14, 16, 20 & 24	0.5	NG, G, EP	5, 7.5, 10, 15
MH434U-6	0.34	4-1/2	15	80	90	120	60	29,700	4.9	73	36	10, 12, 14, 16, 20 & 24	0.5	NG, G, EP	5, 7.5, 10, 15
MH530Y-6	0.3	5-1/2	16.7	110	120	156	78	56,400	4.8	135	68	12, 14, 16, 20, 24, 30 & 36	0.625	NG, G, EP	10, 15, 20
MH536Y-6	0.36	5-1/2	19.8	110	120	157	78	65,300	4.8	157	78	12, 14, 16, 20, 24, 30 & 36	0.625	NG, G, EP	10, 15, 20
MH542Y-6	0.415	5-1/2	22.5	110	120	234	117	73,400	4.8	176	88	12, 14, 16, 20, 24, 30 & 36	0.625	NG, G, EP	10, 15, 20
MH547Y-6	0.47	5-1/2	25.3	110	120	234	117	82,000	4.8	197	98	12, 14, 16, 20, 24, 30 & 36	0.625	NG, G, EP	10, 15, 20
MH736U-6	0.36	7	25.5	80	90	247	124	86,600	3.9	169	84	14, 16, 20, 24, 30 & 36	0.625	NG, G, EP	10, 15, 20
MH740U-6	0.41	7	28.7	80	90	252	126	96,100	3.9	187	94	14, 16, 20, 24, 30 & 36	0.625	NG, G, EP	10, 15, 20
MH745U-6	0.45	7	31.5	80	90	280	140	105,200	3.9	205	103	14, 16, 20, 24, 30 & 36	0.625	NG, G, EP	10, 15, 20
MH745Y-6	0.45	7	31.5	110	120	280	140	140,300	3.9	274	137	14, 16, 20, 24, 30 & 36	0.625	NG, G, EP	10, 15, 20
MH850Q-6	0.5	8-5/8	43.4	50	60	261	131	123,500	3.3	204	102	16, 20, 24, 30, 36 & 42	0.625	NG, G, EP	10, 15, 20
MH939U-6	0.39	9-5/8	38.8	80	90	220	110	146,300	3	220	110	16, 20, 24, 30, 36 & 42	0.625	NG, G, EP	10, 15, 20

Helical Pile Specifications



System Ratings & Specifications

Product	Shaft Specifications					Structural Capacity (Tension & Comp)		Maximum Torque (ft-lbs)	Capacity to Torque Ratio (ft ²)	Geotechnical Capacity (Tension & Comp)		Helix Specifications		Surface Coating	Standard Section Lengths (ft)
	Design Wall Gauge (in)	Outside Diameter (in)	Approx Weight (plf)	Min. Yield Strength (ksi)	Min. Tensile Strength (ksi)	Ultimate (tons)	Allowable (tons)			Ultimate (tons)	Allowable (tons)	Diameters (available in standard & dual cutting edge) (in)	Design Gauge (in)		
MH1050U-6	0.5	10-3/4	54.7	80	90	504	252	293,200	2.8	410	205	18, 20, 24, 30, 36 & 42	1	NG, G, EP	10, 15, 20
MH1250Q-6	0.5	12-3/4	64.6	50	60	280	140	233,000	2.4	280	140	18, 20, 24, 30, 36 & 42	0.625	NG, G, EP	10, 15, 20
MH1338Q-6	0.38	13-3/8	52.7	50	60	233	116	194,200	2.4	233	116	18, 20, 24, 30, 36 & 42	0.625	NG, G, EP	10, 15, 20
MH1650U-6	0.495	16	82	80	90	280	140	265,700	2.1	280	140	20, 24, 30, 36 & 42	0.625	NG, G, EP	10, 15, 20
MH1843Q-6	0.43	18-5/8	83.6	50	60	267	134	281,100	1.9	267	134	24, 30, 36 & 42	0.625	NG, G, EP	10, 15, 20



As Magnum is committed to testing and improving products, these specifications are subject to change. Additional product specifications are available at www.magnumpiling.com and in the Magnum Helical Pile Engineering Reference Manual. Structural capacity is the buckling strength of the shaft and couplings in firm soils. Structural capacity takes into account corrosion over 75 year design life for bare steel in non-severe corrosive soils based on ICC-ES AC308, unless noted otherwise on pile cut sheet. Consult a Magnum corrosion engineer for severe corrosive soils. Geotechnical capacity is the theoretical bearing and pullout capacity in uniform ground when installed at maximum torque. Pullout capacity requires installation to minimum depth of 5 to 12 helix diameters below ground surface depending on soil.

* See Pile cut sheet for special capacity design considerations.

MAGNUM® MS150B Helical Pier

36 Ton Ultimate - 18 Ton Allowable Capacity

High-Strength 1.5" Round-Corner Square Shaft with Forged Upset Coupler

Description: MAGNUM® Helical Piers offer a number of unique advantages as shown below. MAGNUM® products are manufactured in the USA according to our ISO 9001 approved Quality Program. Our Helical Piers utilize rigid bolted couplings to join extension sections and the lead section, extending the helical bearing plates down to the desired bearing stratum. Structural capacities are developed according to AISC 360 and ICC-AC308 considering buckling of 1 ft unbraced length after 75 years of corrosion in moderate to high aggressive soils. Various coatings, custom lengths and helix configurations are available upon request. See Magnum Technical Reference Manual for additional information.

- 1. Patented alternating helix pattern reduces wobble and improves plumbness and tracking.**
- 2. 45-degree miter pilot point aids pier positioning and advancement.**
- 3. Patented MAGNUM® Dual-Cutting Edge helical bearing plates (DCE) enhance penetration through dense soils with occasional cobbles and debris.**
- 4. Sharpened edge on each helix slices through problem soils.**
- 5. Conforming helix shape limits auguring and provides better quality assurance through valid capacity to torque correlations.**

Drawing shows an example pier lead and extension section. Section lengths and number of helices vary with project requirements and soil conditions.

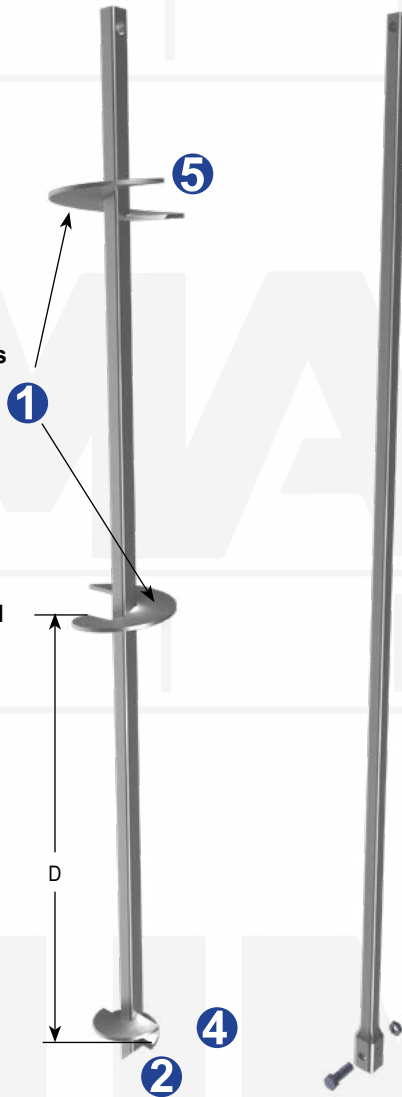
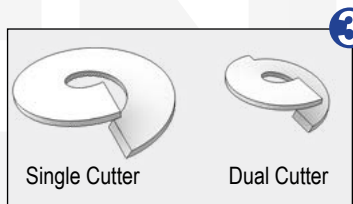

Specifications	
Shaft	RCSS 1.5" x 1.5" ASTM A29 Fy = 90 ksi, or Better
Bolts	(1) 7/8" Diameter SAE J429 Grade 8 Zinc Coated to ASTM B695/F1941
Helices	3/8" Thick, Helix Die-Pressed ASTM A36, or Better 8", 10", 12" & 14" Diameters Available
Spacing 'D'	25-1/2" TYP
Pitch	3"
Coating	Galvanized (G), Bare Steel (NG), Epoxy Powder Coated (EP)
Properties	
10 ft ⁻¹	Ultimate Capacity-to-Torque Ratio
* 7,000 ft-lbs	Maximum Installation Torque
Capacity by Torque	
*** 36 Tons	Ultimate Capacity
18 Tons	Allowable Capacity
Structural Capacity	
** 36 Tons	Ultimate Capacity
18 Tons	Allowable Capacity

Notes: Helical piers shall be installed to appropriate depth into suitable bearing stratum as determined by geotechnical engineer or local practice. Capacity by torque is based on advancing pier to maximum installation torque. A minimum factor of safety of 2.0 is recommended for determining allowable capacity from correlations with final installation torque. Deflections of 0.5" are typical at allowable capacity; a higher factor of safety may be required to achieve smaller deflections. For tension capacity, helical bearing plates must be deeply embedded (5 ~ 7 x ave. helix diameter or as specified by geotechnical engineer). Load tests are recommended when practical.

* Maximum Installation Torque rating per ESR-2997.

** Structural capacity of square-shaft helical piers equals gross area times steel strength. For compression applications, pile shafts must be fully-braced to prevent buckling in order to achieve this capacity. Structural capacity is shown for galvanized product after 75 years of corrosion. Structural capacity of bare steel product is less due to increased corrosion losses.

*** Capacity shown is for multi-helix configurations. For single helix, limit ultimate capacity to 21 Tons.

U.S. Patents 6,058,662, D612,954, Other Patents Pending

MAGNUM
PIERING
designed to support

156 Circle Freeway Dr.
Cincinnati, OH 45246
800-822-7437
www.MagnumPiering.com

MAGNUM® MS175B Helical Pier

52 Ton Ultimate - 26 Ton Allowable Capacity

High-Strength 1.75" Round-Corner Square Shaft with Forged Upset Coupler

Description: MAGNUM® Helical Piers offer a number of unique advantages as shown below. MAGNUM® products are manufactured in the USA according to our ISO 9001 approved Quality Program. Our Helical Piers utilize rigid bolted couplings to join extension sections and the lead section, extending the helical bearing plates down to the desired bearing stratum. Structural capacities are developed according to AISC 360 and ICC-AC308 considering buckling of 1 ft unbraced length after 75 years of corrosion in moderate to high aggressive soils. Various coatings, custom lengths and helix configurations are available upon request. See Magnum Technical Reference Manual for additional information.

1. Patented alternating helix pattern reduces wobble and improves plumbness and tracking.
2. 45-degree miter pilot point aids pier positioning and advancement.
3. Patented MAGNUM® Dual-Cutting Edge helical bearing plates (DCE) enhance penetration through dense soils with occasional cobbles and debris.
4. Sharpened edge on each helix slices through problem soils.
5. Conforming helix shape limits auguring and provides better quality assurance through valid capacity to torque correlations.

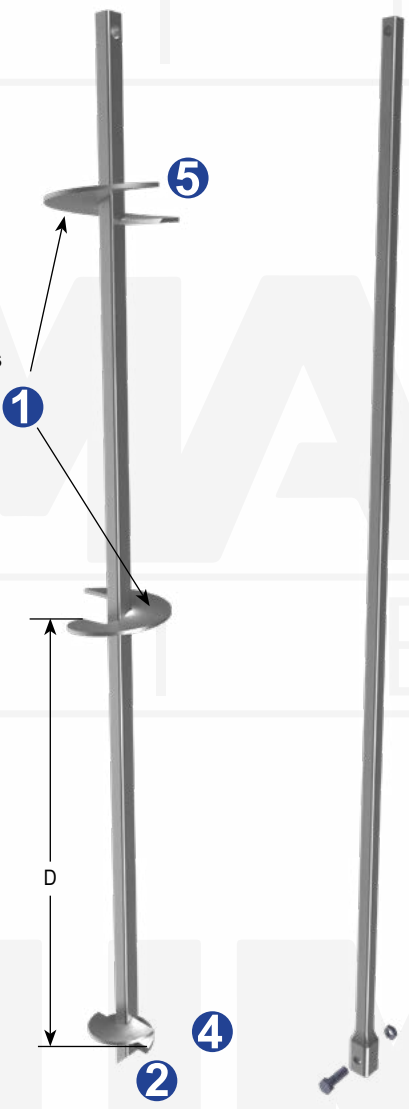

Drawing shows an example pier lead and extension section. Section lengths and number of helices vary with project requirements and soil conditions.

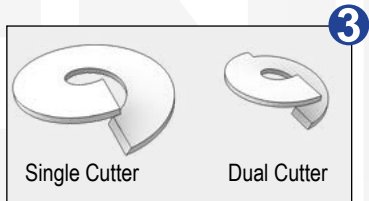

Specifications	
Shaft	RCSS 1.75" x 1.75" ASTM A29 Fy = 90 ksi, or Better
Bolts	(1) 1" Diameter SAE J429 Grade 8 Zinc Coated to ASTM B695/F1941
Helices	1/2" Thick, Helix Die-Pressed ASTM A36, or Better 8", 10", 12" & 14" Diameters Available
Spacing 'D'	25-1/2" TYP
Pitch	3"
Coating	Galvanized (G), Bare Steel (NG), Epoxy Powder Coated (EP)
Properties	
10 ft ⁻¹	Ultimate Capacity-to-Torque Ratio
10,500 ft-lbs	Maximum Installation Torque
Capacity by Torque	
** 52 Tons	Ultimate Capacity
26 Tons	Allowable Capacity
Structural Capacity	
* 58 Tons	Ultimate Capacity
29 Tons	Allowable Capacity

Notes: Helical piers shall be installed to appropriate depth into suitable bearing stratum as determined by geotechnical engineer or local practice. Capacity by torque is based on advancing pier to maximum installation torque. A minimum factor of safety of 2.0 is recommended for determining allowable capacity from correlations with final installation torque. Deflections of 0.5" are typical at allowable capacity; a higher factor of safety may be required to achieve smaller deflections. For tension capacity, helical bearing plates must be deeply embedded (5 ~ 7 x ave. helix diameter or as specified by geotechnical engineer). Load tests are recommended when practical.

* Structural capacity of square-shaft helical piers equals gross area times steel strength. For compression applications, pile shafts must be fully braced to prevent buckling in order to achieve this capacity. Structural capacity is shown for bare steel product after 75 years of corrosion. Structural capacity of galvanized product is more due to decrease in corrosion losses.
 ** Capacity shown is for multi-helix configurations. For single helix, limit ultimate capacity to 34 Tons.



156 Circle Freeway Dr.
Cincinnati, OH 45246
800-822-7437
www.MagnumPiering.com

MAGNUM® MH2325U Helical Piles

29 Ton Ultimate - 14 Ton Allowable Capacity

High-Strength 2.375" Diameter, 0.25" Wall, Round-Shaft with Rigid Coupler

Description: MAGNUM® Helical Piles offer a number of unique advantages as shown below. MAGNUM® products are manufactured in the USA according to our ISO 9001 approved Quality Program. Our Helical Piles utilize rigid bolted couplings to join extension sections and the lead section, extending the helical bearing plates down to the desired bearing stratum. Structural capacities are developed according to AISC 360 and ICC-AC358 considering buckling of 5 ft unbraced length after 75 years of corrosion in moderate to high aggressive soils. Various coatings, custom lengths and helix configurations are available upon request. See Magnum Technical Reference Manual for additional information.

1. Round shafts offer increased lateral and buckling resistance compared to square shafts.
2. Patented alternating helix pattern reduces wobble and improves plumbness and tracking.
3. 45-degree miter pilot point aids pile positioning and advancement.
4. Patented MAGNUM® Dual-Cutting Edge helical bearing plates (DCE) enhance penetration through dense soils with occasional cobbles and debris.
5. Sharpened edge on each helix slices through problem soils.
6. Conforming helix shape limits auguring and provides better quality assurance through valid capacity to torque correlations.

Drawing shows an example pile lead and extension section. Section lengths and number of helices vary with project requirements and soil conditions.

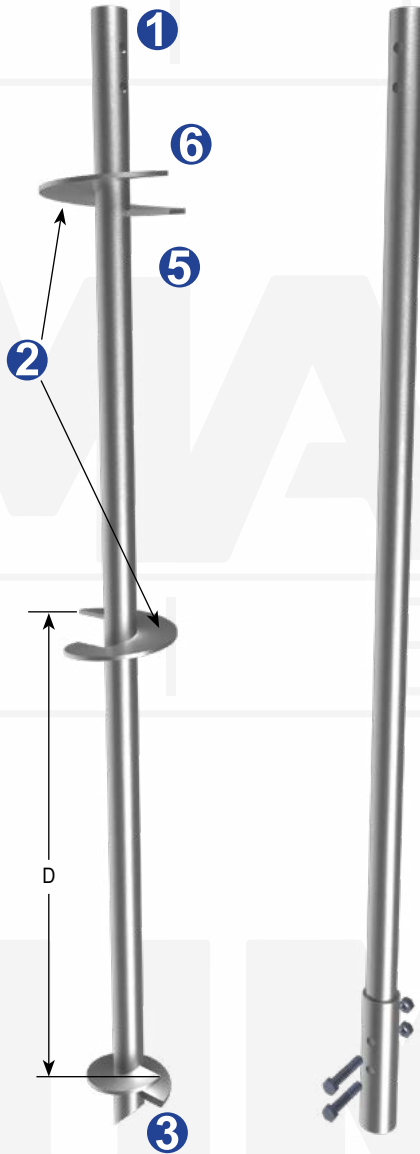
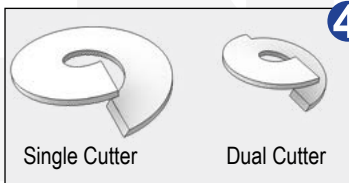

Specifications	
Shaft	HSS 2.375" x 0.25" Nominal, ASTM A252, Fy = 80 ksi, or Better
Bolts	(2) 5/8" Diameter SAE Grade 8 Zinc Coated to ASTM B695/F1941
Helices	3/8" Thick, Helix Die-Pressed ASTM A36, or Better 8", 10", 12", 14" & 16" Diameters Available
Spacing 'D'	* 25-1/2" TYP
Pitch	3"
Coating	Galvanized (G), Bare Steel (NG), Epoxy Powder Coated (EP)
Properties	
10 ft ⁻¹	Ultimate Capacity-to-Torque Ratio
** 5,700 ft-lbs	Maximum Installation Torque
Capacity by Torque	
29 Tons	Ultimate Capacity
14 Tons	Allowable Capacity
Structural Capacity	
*** 34 Tons	Ultimate Capacity
20 Tons	Allowable Capacity

Notes: Helical piles shall be installed to appropriate depth into suitable bearing stratum as determined by geotechnical engineer or local practice. Capacity by torque is based on advancing pile to maximum installation torque. A minimum factor of safety of 2.0 is recommended for determining allowable capacity from correlations with final installation torque. Deflections of 0.5" are typical at allowable capacity; a higher factor of safety may be required to achieve smaller deflections. For tension capacity, helical bearing plates must be deeply embedded (5 ~ 7 x ave. helix diameter or as specified by geotechnical engineer). Load tests are recommended when practical.

* Spacing = 34-1/2" with 16" Ø helix.

** Maximum Installation Torque rating considers Maximum Driving Stress per ASCE 20.

*** Structural capacity is shown for bare steel product after 75 years of corrosion. Structural capacity of galvanized product is more due to decrease in corrosion losses.

MAGNUM
PIERING
designed to support

156 Circle Freeway Dr.
Cincinnati, OH 45246
800-822-7437
www.MagnumPiering.com

U.S. Patents 6,058,662, D612,954, Other Patents Pending

MAGNUM® MH222U Helical Piles

35 Ton Ultimate - 17.5 Ton Allowable Capacity

High-Strength 2.875" Diameter, 0.217" Wall, Round-Shaft with Rigid Coupler

Description: MAGNUM® Helical Piles offer a number of unique advantages as shown below. MAGNUM® products are manufactured in the USA according to our ISO 9001 approved Quality Program. Our Helical Piles utilize rigid bolted couplings to join extension sections and the lead section, extending the helical bearing plates down to the desired bearing stratum. Structural capacities are developed according to AISC 360 and ICC-AC308 considering buckling of 5 ft unbraced length after 75 years of corrosion in moderate to high aggressive soils. Various coatings, custom lengths and helix configurations are available upon request. See Magnum Technical Reference Manual for additional information.

1. Round shafts offer increased lateral and buckling resistance compared to square shafts.
2. Patented alternating helix pattern reduces wobble and improves plumbness and tracking.
3. 45-degree miter pilot point aids pile positioning and advancement.
4. Patented MAGNUM® Dual-Cutting Edge helical bearing plates (DCE) enhance penetration through dense soils with occasional cobbles and debris.
5. Sharpened edge on each helix slices through problem soils.
6. Conforming helix shape limits auguring and provides better quality assurance through valid capacity to torque correlations.

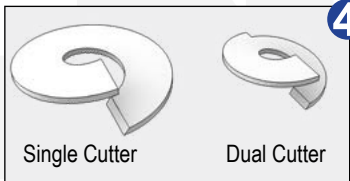
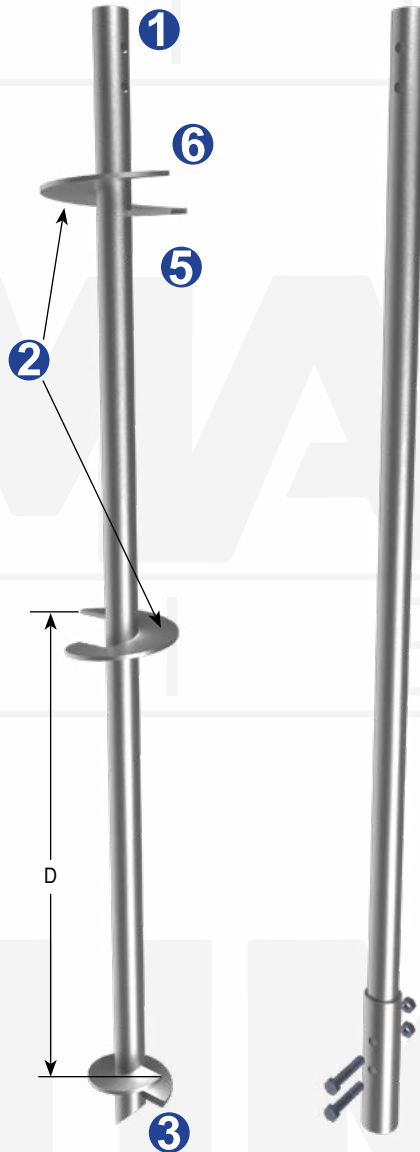

Specifications	
Shaft	HSS 2.875" x 0.217" Nominal ASTM A252, Fy = 80 ksi, or Better
Bolts	(2) 3/4" Diameter SAE J429 Grade 8 Zinc Coated to ASTM B695/F1941
Helices	3/8" Thick, Helix Die-Pressed ASTM A36, or Better 8", 10", 12", 14" & 16" Diameters Available
Spacing 'D'	* 25-1/2" TYP
Pitch	3"
Coating	Galvanized (G), Bare Steel (NG), Epoxy Powder Coated (EP)
Properties	
9 ft-1	Ultimate Capacity-to-Torque Ratio
** 7,800 ft-lbs	Maximum Installation Torque
Capacity by Torque	
35 Tons	Ultimate Capacity
17.5 Tons	Allowable Capacity
Structural Capacity	
*** 41 Tons	Ultimate Capacity
21 Tons	Allowable Capacity

Drawing shows an example pile lead and extension section. Section lengths and number of helices vary with project requirements and soil conditions.

Notes: Helical piles shall be installed to appropriate depth into suitable bearing stratum as determined by geotechnical engineer or local practice. Capacity by torque is based on advancing pile to maximum installation torque. A minimum factor of safety of 2.0 is recommended for determining allowable capacity from correlations with final installation torque. Deflections of 0.5" are typical at allowable capacity; a higher factor of safety may be required to achieve smaller deflections. For tension capacity, helical bearing plates must be deeply embedded (5 ~ 7 x ave. helix diameter or as specified by geotechnical engineer). Load tests are recommended when practical.

* Spacing = 34-1/2" with 16" Ø helix.
 ** Maximum Installation Torque rating considers Maximum Driving Stress per ASCE 20.
 *** Structural capacity is shown for bare steel product after 75 years of corrosion.
 Structural capacity of galvanized product is more due to decrease in corrosion losses.



156 Circle Freeway Dr.
 Cincinnati, OH 45246
 800-822-7437
www.MagnumPiering.com

MAGNUM® MH227U Helical Piles

42 Ton Ultimate - 21 Ton Allowable Capacity

High-Strength 2.875" Diameter, 0.276" Wall, Round-Shaft with Rigid Coupler

Description: MAGNUM® Helical Piles offer a number of unique advantages as shown below. MAGNUM® products are manufactured in the USA according to our ISO 9001 approved Quality Program. Our Helical Piles utilize rigid bolted couplings to join extension sections and the lead section, extending the helical bearing plates down to the desired bearing stratum. Structural Capacities are developed according to AISC 360 and ICC-AC358 considering buckling of 5 ft unbraced length after 75 years of corrosion in moderate to high aggressive soils. Various coatings, custom lengths and helix configurations are available upon request. See Magnum Technical Reference Manual for additional information.

1. Round shafts offer increased lateral and buckling resistance compared to square shafts.
2. Patented alternating helix pattern reduces wobble and improves plumbness and tracking.
3. 45-degree miter pilot point aids pile positioning and advancement.
4. Patented MAGNUM® Dual-Cutting Edge helical bearing plates (DCE) enhance penetration through dense soils with occasional cobbles and debris.
5. Sharpened edge on each helix slices through problem soils.
6. Conforming helix shape limits auguring and provides better quality assurance through valid capacity to torque correlations.

Drawing shows an example pile lead and extension section. Section lengths and number of helices vary with project requirements and soil conditions.

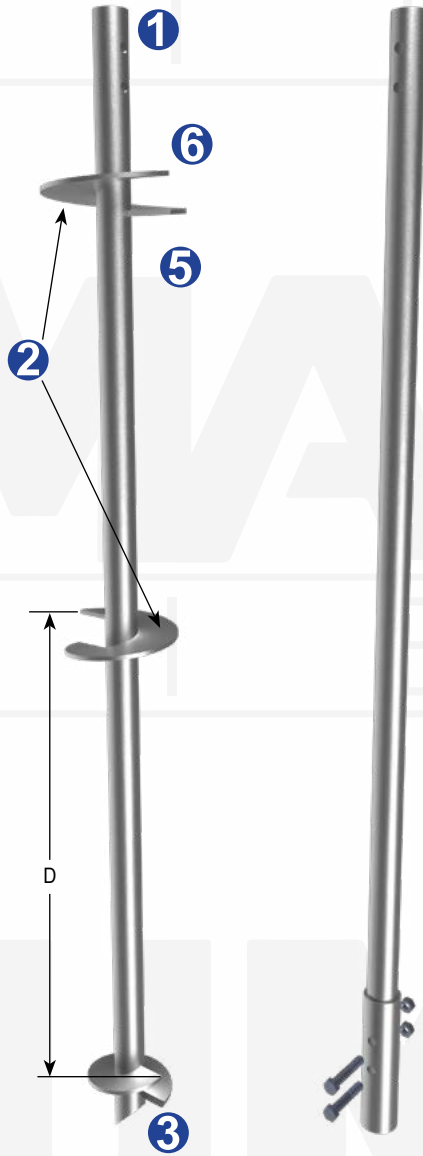
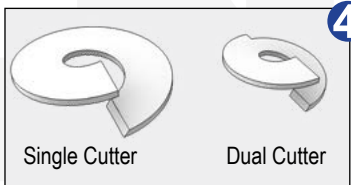

Specifications	
Shaft	HSS 2.875" x 0.276" Nominal ASTM A252, Fy = 80 ksi, or Better
Bolts	(2) 3/4" Diameter SAE J429 Grade 8 Zinc Coated to ASTM B695/F1941
Helices	3/8" Thick, Helix Die-Pressed ASTM A36, or Better 8", 10", 12", 14" & 16" Diameters Available
Spacing 'D'	* 25-1/2" TYP
Pitch	3"
Coating	Galvanized (G), Bare Steel (NG), Epoxy Powder Coated (EP)
Properties	
9 ft ⁻¹	Ultimate Capacity-to-Torque Ratio
** 9,400 ft-lbs	Maximum Installation Torque
Capacity by Torque	
42 Tons	Ultimate Capacity
21 Tons	Allowable Capacity
Structural Capacity	
*** 51 Tons	Ultimate Capacity
25 Tons	Allowable Capacity

Notes: Helical piles shall be installed to appropriate depth into suitable bearing stratum as determined by geotechnical engineer or local practice. Capacity by torque is based on advancing pile to maximum installation torque. A minimum factor of safety of 2.0 is recommended for determining allowable capacity from correlations with final installation torque. Deflections of 0.5" are typical at allowable capacity; a higher factor of safety may be required to achieve smaller deflections. For tension capacity, helical bearing plates must be deeply embedded (5 ~ 7 x ave. helix diameter or as specified by geotechnical engineer). Load tests are recommended when practical.

* Spacing = 34-1/2" with 16" Ø helix.

** Maximum Installation Torque rating considers Maximum Driving Stress per ASCE 20.

*** Structural capacity is shown for galvanized steel product after 75 years of corrosion.

Structural capacity of bare steel product is less due to increase in corrosion losses.

MAGNUM
PIERING
designed to support

156 Circle Freeway Dr.
Cincinnati, OH 45246
800-822-7437

www.MagnumPiering.com

U.S. Patents 6,058,662, D612,954, Other Patents Pending

MAGNUM® MH227U-6 Helical Piles

34 Ton Ultimate - 17 Ton Allowable Capacity

High-Strength 2.875" Diameter, 0.276" Wall, Round-Shaft with Rigid Coupler

Description: MAGNUM® Helical Piles offer a number of unique advantages as shown below. MAGNUM® products are manufactured in the USA according to our ISO 9001 approved Quality Program. Our Helical Piles utilize rigid bolted couplings to join extension sections and the lead section, extending the helical bearing plates down to the desired bearing stratum. Structural Capacities are developed according to AISC 360 and ICC-AC308 considering buckling of 5 ft unbraced length after 75 years of corrosion in moderate to high aggressive soils. Various coatings, custom lengths and helix configurations are available upon request. See Magnum Technical Reference Manual for additional information.

1. Round shafts offer increased lateral and buckling resistance compared to square shafts.
2. Patented alternating helix pattern reduces wobble and improves plumbness and tracking.
3. 45-degree miter pilot point aids pile positioning and advancement.
4. Patented MAGNUM® Dual-Cutting Edge helical bearing plates (DCE) enhance penetration through dense soils with occasional cobbles and debris.
5. Sharpened edge on each helix slices through problem soils.
6. Conforming helix shape limits auguring and provides better quality assurance through valid capacity to torque correlations.

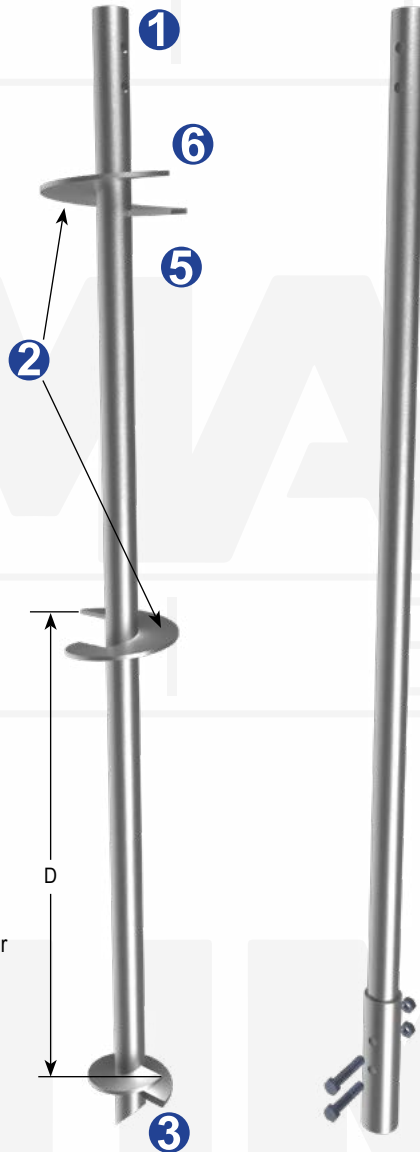

Drawing shows an example pile lead and extension section. Section lengths and number of helices vary with project requirements and soil conditions.

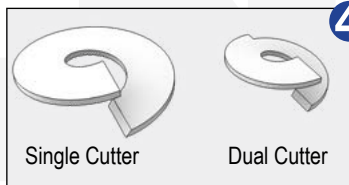

Specifications	
Shaft	HSS 2.875" x 0.276" Nominal ASTM A252, Fy = 80 ksi, or Better
Bolts	(2) 3/4" Diameter SAE J429 Grade 8 Zinc Coated to ASTM B695/F1941
Helices	3/8" Thick, Helix Die-Pressed ASTM A36, or Better 8", 10", 12", 14" & 16" Diameters Available
Spacing 'D'	* 27" TYP
Pitch	6"
Coating	Galvanized (G), Bare Steel (NG), Epoxy Powder Coated (EP)
Properties	
7.3 ft ⁻¹	Ultimate Capacity-to-Torque Ratio
** 9,400 ft-lbs	Maximum Installation Torque
Capacity by Torque	
34 Tons	Ultimate Capacity
17 Tons	Allowable Capacity
Structural Capacity	
*** 51 Tons	Ultimate Capacity
25 Tons	Allowable Capacity

Notes: Helical piles shall be installed to appropriate depth into suitable bearing stratum as determined by geotechnical engineer or local practice. Capacity by torque is based on advancing pile to maximum installation torque. A minimum factor of safety of 2.0 is recommended for determining allowable capacity from correlations with final installation torque. Deflections of 0.5" are typical at allowable capacity; a higher factor of safety may be required to achieve smaller deflections. For tension capacity, helical bearing plates must be deeply embedded (5 ~ 7 x ave. helix diameter or as specified by geotechnical engineer). Load tests are recommended when practical.

* Spacing = 39" with 16" Ø helix.
 ** Maximum Installation Torque rating considers Maximum Driving Stress per ASCE 20.
 *** Structural capacity is shown for galvanized steel product after 75 years of corrosion. Structural capacity of bare steel product is less due to increase in corrosion losses.



156 Circle Freeway Dr.
 Cincinnati, OH 45246
 800-822-7437
www.MagnumPiering.com

MAGNUM® MH313B Helical Piles

18 Ton Ultimate - 9 Ton Allowable Capacity

High-Strength 3.00" Diameter, 0.125" Wall, Round-Shaft with Rigid Coupler

Description: MAGNUM® Helical Piles offer a number of unique advantages as shown below. MAGNUM® products are manufactured in the USA according to our ISO 9001 approved Quality Program. Our Helical Piles utilize rigid bolted couplings to join extension sections and the lead section, extending the helical bearing plates down to the desired bearing stratum. Structural capacities are developed according to AISC 360 and ICC-AC358 considering buckling of 5 ft unbraced length after 75 years of corrosion in moderate to high aggressive soils. Various coatings, custom lengths and helix configurations are available upon request. See Magnum Technical Reference Manual for additional information.

1. Round shafts offer increased lateral and buckling resistance compared to square shafts.
2. Patented alternating helix pattern reduces wobble and improves plumbness and tracking.
3. 45-degree miter pilot point aids pile positioning and advancement.
4. Patented MAGNUM® Dual-Cutting Edge helical bearing plates (DCE) enhance penetration through dense soils with occasional cobbles and debris.
5. Sharpened edge on each helix slices through problem soils.
6. Conforming helix shape limits auguring and provides better quality assurance through valid capacity to torque correlations.

Drawing shows an example pile lead and extension section. Section lengths and number of helices vary with project requirements and soil conditions.

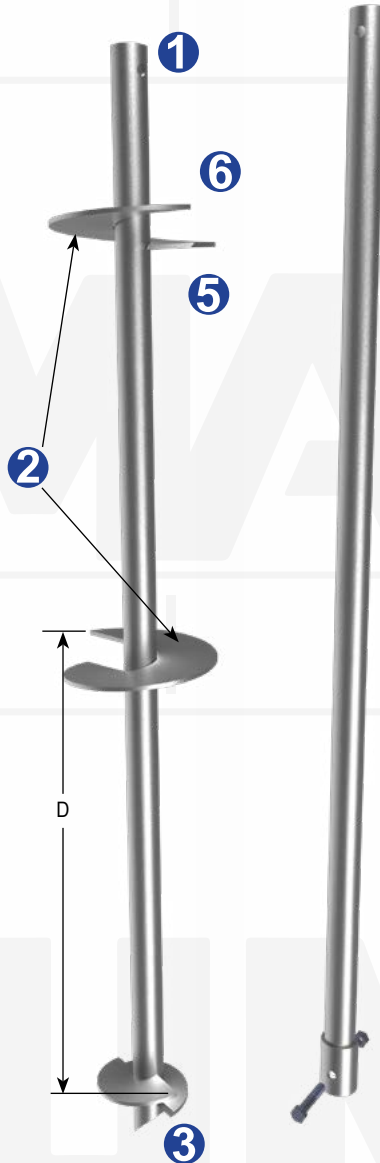
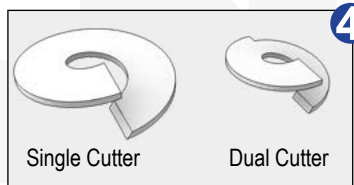

Specifications	
Shaft	HSS 3.00" x 0.125" Nominal ASTM A513, Fy = 65 ksi, or Better
Bolts	(1) 7/8" Diameter SAE J429 Grade 5 Zinc Coated to ASTM B695/F1941
Helices	3/8" Thick, Helix Die-Pressed ASTM A36, or Better 8", 10", 12", 14" & 16" Diameters Available
Spacing 'D'	* 25-1/2" TYP
Pitch	3"
Coating	Galvanized (G), Bare Steel (NG), Epoxy Powder Coated (EP)
Properties	
8 ft ⁻¹	Ultimate Capacity-to-Torque Ratio
** 4,500 ft-lbs	Maximum Installation Torque
Capacity by Torque	
*** 18 Tons	Ultimate Capacity
9 Tons	Allowable Capacity
Structural Capacity	
18 Tons	Ultimate Capacity
9 Tons	Allowable Capacity

Notes: Helical piles shall be installed to appropriate depth into suitable bearing stratum as determined by geotechnical engineer or local practice. Capacity by torque is based on advancing pile to maximum installation torque. A minimum factor of safety of 2.0 is recommended for determining allowable capacity from correlations with final installation torque. Deflections of 0.5" are typical at allowable capacity; a higher factor of safety may be required to achieve smaller deflections. For tension capacity, helical bearing plates must be deeply embedded (5 ~ 7 x ave. helix diameter or as specified by geotechnical engineer). Load tests are recommended when practical.

* Spacing = 34-1/2" with 16" Ø helix.

** Maximum Installation Torque rating considers Maximum Driving Stress per ASCE 20.

*** Structural capacity is shown for galvanized product after 75 years of corrosion.

Structural capacity of bare steel product is less due to increased corrosion losses.



156 Circle Freeway Dr.
Cincinnati, OH 45246
800-822-7437

www.MagnumPiering.com

U.S. Patents 6,058,662, D612,954, Other Patents Pending

MAGNUM[®] MH313BR Helical Piles

24 Ton Ultimate - 12 Ton Allowable Capacity

High-Strength 3.0" Diameter, 0.125" Wall, Round-Shaft with Reinforced (R) Dual Sleeve Rigid Coupler

Description: MAGNUM[®] Helical Piles offer a number of unique advantages as shown below. MAGNUM[®] products are manufactured in the USA according to our ISO 9001 approved Quality Program. Our Helical Piles utilize rigid bolted couplings to join extension sections and the lead section, extending the helical bearing plates down to the desired bearing stratum. Structural capacities are developed according to AISC 360 and ICC-AC308 considering buckling of 5 ft unbraced length after 75 years of corrosion in moderate to high aggressive soils. Various coatings, custom lengths and helix configurations are available upon request. See Magnum Technical Reference Manual for additional information.

1. Round shafts offer increased lateral and buckling resistance compared to square shafts.
2. Patented alternating helix pattern reduces wobble and improves plumbness and tracking.
3. 45-degree miter pilot point aids pile positioning and advancement.
4. Patented MAGNUM[®] Dual-Cutting Edge helical bearing plates (DCE) enhance penetration through dense soils with occasional cobbles and debris.
5. Sharpened edge on each helix slices through problem soils.
6. Conforming helix shape limits auguring and provides better quality assurance through valid capacity to torque correlations.

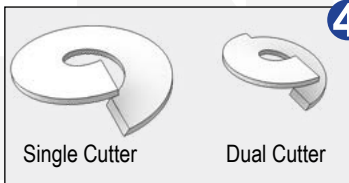
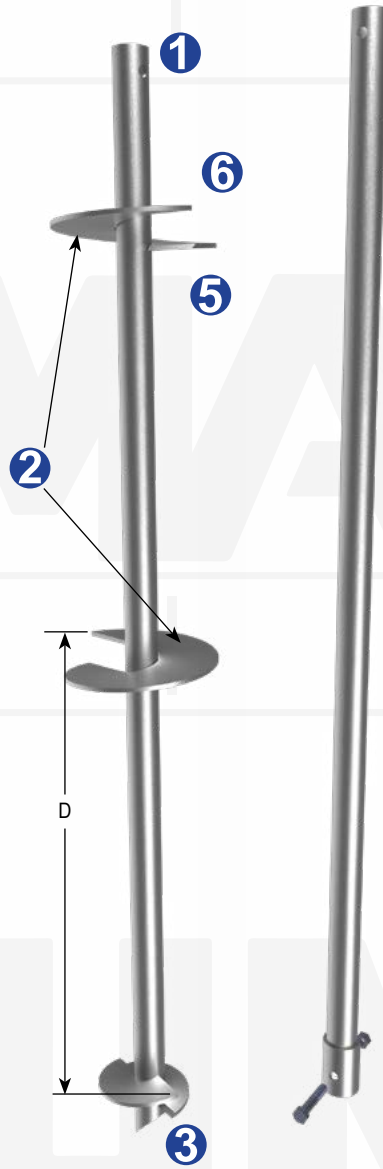

Specifications	
Shaft	HSS 3.00" x 0.125" Nominal ASTM A513, Fy = 65 ksi, or Better
Bolts	(1) 7/8" Diameter SAE J429 Grade 5 Zinc Coated to ASTM B695/F1941
Helices	3/8" Thick, Helix Die-Pressed ASTM A36, or Better 8", 10", 12", 14" & 16" Diameters Available
Spacing 'D'	* 25-1/2" TYP
Pitch	3"
Coating	Galvanized (G), Bare Steel (NG), Epoxy Powder Coated (EP)
Properties	
8 ft ⁻¹	Ultimate Capacity-to-Torque Ratio
** 5,900 ft-lbs	Maximum Installation Torque
Capacity by Torque	
24 Tons	Ultimate Capacity
12 Tons	Allowable Capacity
Structural Capacity	
*** 29 Tons	Ultimate Capacity
15 Tons	Allowable Capacity

Drawing shows an example pile lead and extension section. Section lengths and number of helices vary with project requirements and soil conditions.

Notes: Helical piles shall be installed to appropriate depth into suitable bearing stratum as determined by geotechnical engineer or local practice. Capacity by torque is based on advancing pile to maximum installation torque. A minimum factor of safety of 2.0 is recommended for determining allowable capacity from correlations with final installation torque. Deflections of 0.5" are typical at allowable capacity; a higher factor of safety may be required to achieve smaller deflections. For tension capacity, helical bearing plates must be deeply embedded (5 ~ 7 x ave. helix diameter or as specified by geotechnical engineer). Load tests are recommended when practical.

* Spacing = 34-1/2" with 16" Ø helix.
 ** Maximum Installation Torque rating considers Maximum Driving Stress per ASCE 20.
 *** Structural capacity is shown for galvanized product after 75 years of corrosion.
 Structural capacity of bare steel product is less due to increased corrosion losses.



156 Circle Freeway Dr.
 Cincinnati, OH 45246
 800-822-7437
www.MagnumPiering.com

MAGNUM® MH325B Helical Piles

33 Ton Ultimate - 16.5 Ton Allowable Capacity

High-Strength 3.0" Diameter, 0.27" Wall, Round-Shaft with Rigid Coupler

Description: MAGNUM® Helical Piles offer a number of unique advantages as shown below. MAGNUM® products are manufactured in the USA according to our ISO 9001 approved Quality Program. Our Helical Piles utilize rigid bolted couplings to join extension sections and the lead section, extending the helical bearing plates down to the desired bearing stratum. Structural capacities are developed according to AISC 360 and ICC-AC358 considering buckling of 5 ft unbraced length after 75 years of corrosion in moderate to high aggressive soils. Various coatings, custom lengths and helix configurations are available upon request. See Magnum Technical Reference Manual for additional information.

1. Round shafts offer increased lateral and buckling resistance compared to square shafts.
2. Patented alternating helix pattern reduces wobble and improves plumbness and tracking.
3. 45-degree miter pilot point aids pile positioning and advancement.
4. Patented MAGNUM® Dual-Cutting Edge helical bearing plates (DCE) enhance penetration through dense soils with occasional cobbles and debris.
5. Sharpened edge on each helix slices through problem soils.
6. Conforming helix shape limits auguring and provides better quality assurance through valid capacity to torque correlations.

Drawing shows an example pile lead and extension section. Section lengths and number of helices vary with project requirements and soil conditions.

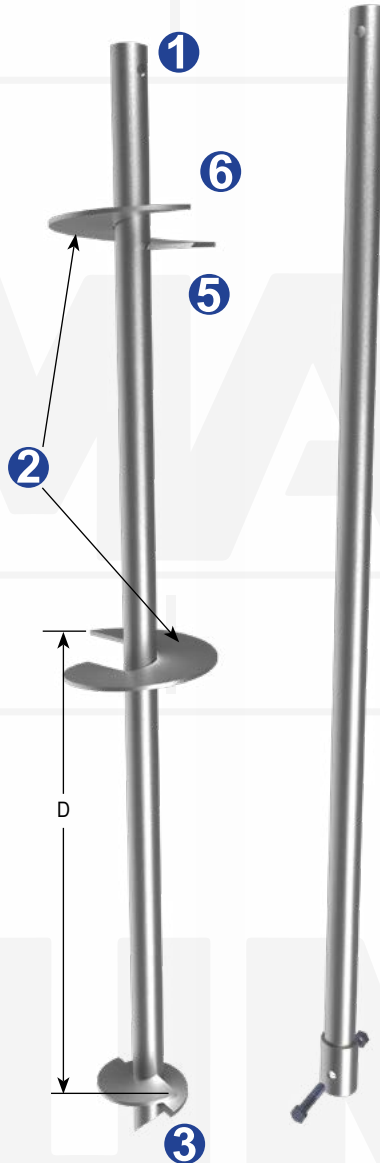
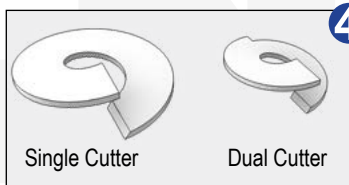

Specifications	
Shaft	HSS 3.00" x 0.27" Nominal ASTM A513, Fy = 65 ksi, or Better
Bolts	(1) 7/8" Diameter SAE J429 Grade 5 Zinc Coated to ASTM B695/F1941
Helices	3/8" Thick, Helix Die-Pressed ASTM A36, or Better 8", 10", 12", 14" & 16" Diameters Available
Spacing 'D'	* 25-1/2" TYP
Pitch	3"
Coating	Galvanized (G), Bare Steel (NG), Epoxy Powder Coated (EP)
Properties	
8 ft ⁻¹	Ultimate Capacity-to-Torque Ratio
** 8,300 ft-lbs	Maximum Installation Torque
Capacity by Torque	
33 Tons	Ultimate Capacity
16.5 Tons	Allowable Capacity
Structural Capacity	
*** 33 Tons	Ultimate Capacity
16.5 Tons	Allowable Capacity

Notes: Helical piles shall be installed to appropriate depth into suitable bearing stratum as determined by geotechnical engineer or local practice. Capacity by torque is based on advancing pile to maximum installation torque. A minimum factor of safety of 2.0 is recommended for determining allowable capacity from correlations with final installation torque. Deflections of 0.5" are typical at allowable capacity; a higher factor of safety may be required to achieve smaller deflections. For tension capacity, helical bearing plates must be deeply embedded (5 ~ 7 x ave. helix diameter or as specified by geotechnical engineer). Load tests are recommended when practical.

* Spacing = 34-1/2" with 16" Ø helix.

** Maximum Installation Torque rating considers Maximum Driving Stress per ASCE 20.

*** Structural capacity is shown for galvanized product after 75 years of corrosion. Structural capacity of bare steel product is less due to increased corrosion losses.

MAGNUM
PIERING
designed to support

156 Circle Freeway Dr.
Cincinnati, OH 45246
800-822-7437
www.MagnumPiering.com

U.S. Patents 6,058,662, D612,954, Other Patents Pending

MAGNUM® MH325BR Helical Piles

50 Ton Ultimate - 25 Ton Allowable Capacity

High-Strength 3.0" Diameter, 0.27" Wall, Round-Shaft with Reinforced (R) Dual Sleeve Coupler

Description: MAGNUM® Helical Piles offer a number of unique advantages as shown below. MAGNUM® products are manufactured in the USA according to our ISO 9001 approved Quality Program. Our Helical Piles utilize rigid bolted couplings to join extension sections and the lead section, extending the helical bearing plates down to the desired bearing stratum. Structural Capacities are developed according to AISC 360 and ICC-AC308 considering buckling of 5 ft unbraced length after 75 years of corrosion in moderate to high aggressive soils. Various coatings, custom lengths and helix configurations are available upon request. See Magnum Technical Reference Manual for additional information.

1. Round shafts offer increased lateral and buckling resistance compared to square shafts.
2. Patented alternating helix pattern reduces wobble and improves plumbness and tracking.
3. 45-degree miter pilot point aids pile positioning and advancement.
4. Patented MAGNUM® Dual-Cutting Edge helical bearing plates (DCE) enhance penetration through dense soils with occasional cobbles and debris.
5. Sharpened edge on each helix slices through problem soils.
6. Conforming helix shape limits auguring and provides better quality assurance through valid capacity to torque correlations.

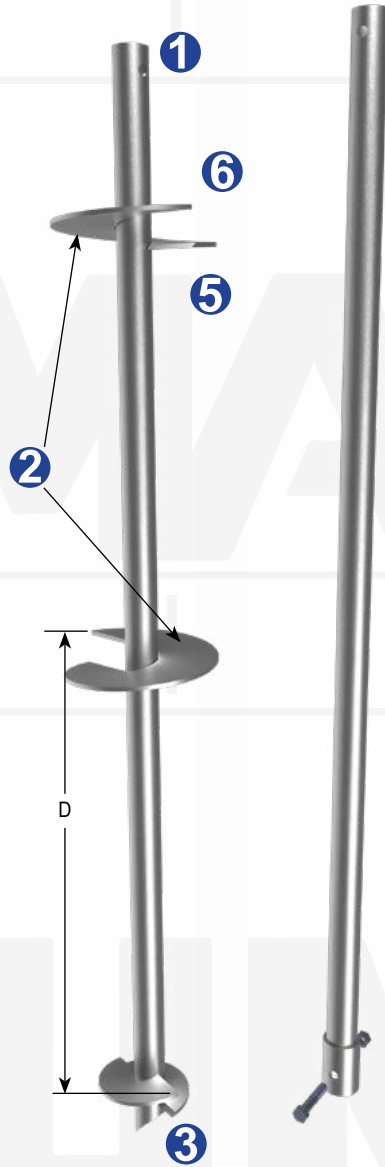

Drawing shows an example pile lead and extension section. Section lengths and number of helices vary with project requirements and soil conditions.

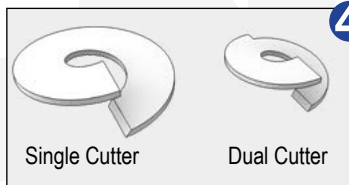

Specifications	
Shaft	HSS 3.00" x 0.27" Nominal ASTM A513, Fy = 65 ksi, or Better
Bolts	(1) 1" Diameter SAE J429 Grade 8 Zinc Coated to ASTM B695/F1941
Helices	3/8" Thick, Helix Die-Pressed ASTM A36, or Better 8", 10", 12", 14" & 16" Diameters Available
Spacing 'D'	* 25-1/2" TYP
Pitch	3"
Coating	Galvanized (G), Bare Steel (NG), Epoxy Powder Coated (EP)
Properties	
8 ft ⁻¹	Ultimate Capacity-to-Torque Ratio
** 12,500 ft-lbs	Maximum Installation Torque
Capacity by Torque	
50 Tons	Ultimate Capacity
25 Tons	Allowable Capacity
Structural Capacity	
*** 54 Tons	Ultimate Capacity
27 Tons	Allowable Capacity

Notes: Helical piles shall be installed to appropriate depth into suitable bearing stratum as determined by geotechnical engineer or local practice. Capacity by torque is based on advancing pile to maximum installation torque. A minimum factor of safety of 2.0 is recommended for determining allowable capacity from correlations with final installation torque. Deflections of 0.5" are typical at allowable capacity; a higher factor of safety may be required to achieve smaller deflections. For tension capacity, helical bearing plates must be deeply embedded (5 ~ 7 x ave. helix diameter or as specified by geotechnical engineer). Load tests are recommended when practical.

* Spacing = 34-1/2" with 16" Ø helix.
 ** Maximum Installation Torque rating per ESR-2997.
 *** Structural capacity is shown for galvanized product after 75 years of corrosion. Structural capacity of bare steel product is less due to increased corrosion losses.



156 Circle Freeway Dr.
 Cincinnati, OH 45246
 800-822-7437
www.MagnumPiering.com

MAGNUM® MH325BR-6 Helical Piles

44 Ton Ultimate - 22 Ton Allowable Capacity

High-Strength 3.0" Diameter, 0.27" Wall, Round-Shaft with Reinforced (R) Dual Sleeve Coupler

Description: MAGNUM® Helical Piles offer a number of unique advantages as shown below. MAGNUM® products are manufactured in the USA according to our ISO 9001 approved Quality Program. Our Helical Piles utilize rigid bolted couplings to join extension sections and the lead section, extending the helical bearing plates down to the desired bearing stratum. Structural capacities are developed according to AISC 360 and ICC-AC358 considering buckling of 5 ft unbraced length after 75 years of corrosion in moderate to high aggressive soils. Various coatings, custom lengths and helix configurations are available upon request. See Magnum Technical Reference Manual for additional information.

1. Round shafts offer increased lateral and buckling resistance compared to square shafts.
2. Patented alternating helix pattern reduces wobble and improves plumbness and tracking.
3. 45-degree miter pilot point aids pile positioning and advancement.
4. Patented MAGNUM® Dual-Cutting Edge helical bearing plates (DCE) enhance penetration through dense soils with occasional cobbles and debris.
5. Sharpened edge on each helix slices through problem soils.
6. Conforming helix shape limits auguring and provides better quality assurance through valid capacity to torque correlations.

Drawing shows an example pile lead and extension section. Section lengths and number of helices vary with project requirements and soil conditions.

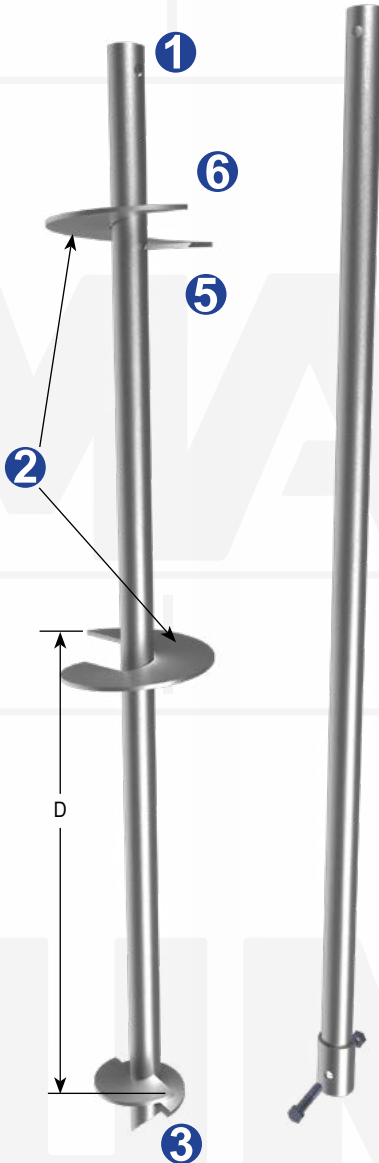
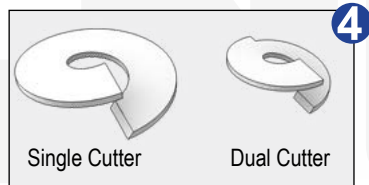

Specifications	
Shaft	HSS 3.00" x 0.27" Nominal ASTM A513, Fy = 65 ksi, or Better
Bolts	(1) 1" Diameter SAE J429 Grade 8 Zinc Coated to ASTM B695/F1941
Helices	3/8" or 1/2" Thick, Helix Die-Pressed ASTM A36, or Better 10", 12", 14" & 16" Diameters Available
Spacing 'D'	* 27" TYP
Pitch	6"
Coating	Galvanized (G), Bare Steel (NG), Epoxy Powder Coated (EP)
Properties	
7 ft ⁻¹	Ultimate Capacity-to-Torque Ratio
** 12,500 ft-lbs	Maximum Installation Torque
Capacity by Torque	
44 Tons	Ultimate Capacity
22 Tons	Allowable Capacity
Structural Capacity	
*** 54 Tons	Ultimate Capacity
27 Tons	Allowable Capacity

Notes: Helical piles shall be installed to appropriate depth into suitable bearing stratum as determined by geotechnical engineer or local practice. Capacity by torque is based on advancing pile to maximum installation torque. A minimum factor of safety of 2.0 is recommended for determining allowable capacity from correlations with final installation torque. Deflections of 0.5" are typical at allowable capacity; a higher factor of safety may be required to achieve smaller deflections. For tension capacity, helical bearing plates must be deeply embedded (5 ~ 7 x ave. helix diameter or as specified by geotechnical engineer). Load tests are recommended when practical.

* Spacing = 39" with 16" Ø helix.

** Maximum Installation Torque rating per ESR-2997.

*** Structural capacity is shown for galvanized product after 75 years of corrosion. Structural capacity of bare steel product is less due to increased corrosion losses.

MAGNUM
PIERING
designed to support

156 Circle Freeway Dr.
Cincinnati, OH 45246
800-822-7437
www.MagnumPiering.com

U.S. Patents 6,058,662, D612,954, Other Patents Pending

MAGNUM[®] MH3521U Helical Piles

40 Ton Ultimate - 20 Ton Allowable Capacity

High-Strength 3.50" Diameter, 0.21" Wall, Round-Shaft with Rigid Coupler

Description: MAGNUM[®] Helical Piles offer a number of unique advantages as shown below. MAGNUM[®] products are manufactured in the USA according to our ISO 9001 approved Quality Program. Our Helical Piles utilize rigid bolted couplings to join extension sections and the lead section, extending the helical bearing plates down to the desired bearing stratum. Structural capacities are developed according to AISC 360 and ICC-AC308 considering buckling of 5 ft unbraced length after 75 years of corrosion in moderate to high aggressive soils. Various coatings, custom lengths and helix configurations are available upon request. See Magnum Technical Reference Manual for additional information.

1. Round shafts offer increased lateral and buckling resistance compared to square shafts.
2. Patented alternating helix pattern reduces wobble and improves plumbness and tracking.
3. 45-degree miter pilot point aids pile positioning and advancement.
4. Patented MAGNUM[®] Dual-Cutting Edge helical bearing plates (DCE) enhance penetration through dense soils with occasional cobbles and debris.
5. Sharpened edge on each helix slices through problem soils.
6. Conforming helix shape limits auguring and provides better quality assurance through valid capacity to torque correlations.

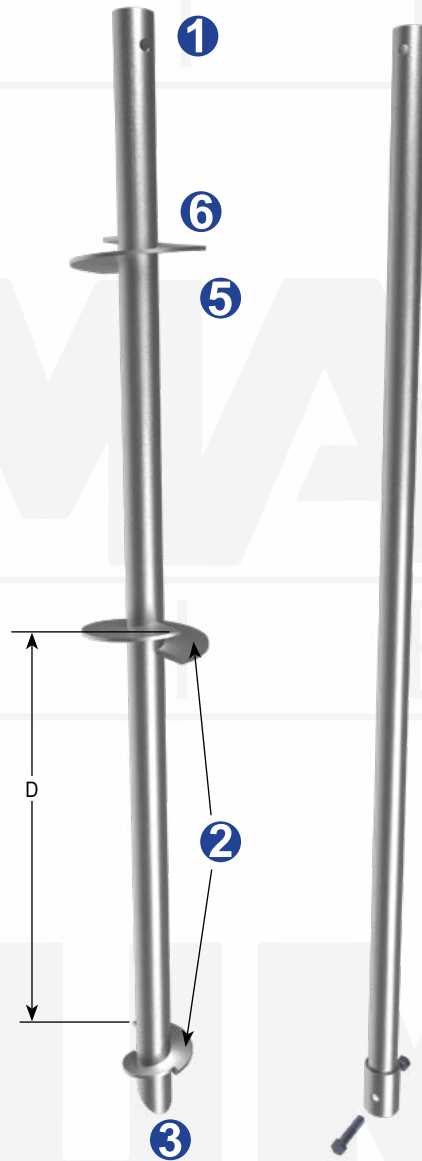

Drawing shows an example pile lead and extension section. Section lengths and number of helices vary with project requirements and soil conditions.

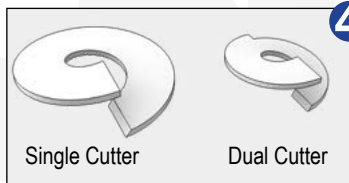

Specifications	
Shaft	3.5" x 0.21" Nominal, ASTM A252, Fy = 80 ksi, or Better
Bolts	(1) 1" Diameter SAE J429 Grade 8 Zinc Coated to ASTM B695/F1941
Helices	3/8" Thick, Helix Die-Pressed ASTM A36, or Better 10", 12", 14", 16", 20" & 24" Diameters Available
Spacing 'D'	* 25-1/2" TYP
Pitch	3"
Coating	Galvanized (G), Bare Steel (NG), Epoxy Powder Coated (EP) Coating
Properties	
7 ft ⁻¹	Ultimate Capacity-to-Torque Ratio
** 11,400 ft-lbs	Maximum Installation Torque
Capacity by Torque	
40 Tons	Ultimate Capacity
20 Tons	Allowable Capacity
Structural Capacity	
*** 42 Tons	Ultimate Capacity
21 Tons	Allowable Capacity

Notes: Helical piles shall be installed to appropriate depth into suitable bearing stratum as determined by geotechnical engineer or local practice. Capacity by torque is based on advancing pile to maximum installation torque. A minimum factor of safety of 2.0 is recommended for determining allowable capacity from correlations with final installation torque. Deflections of 0.5" are typical at allowable capacity; a higher factor of safety may be required to achieve smaller deflections. For tension capacity, helical bearing plates must be deeply embedded (5 ~ 7 x ave. helix diameter or as specified by geotechnical engineer). Load tests are recommended when practical.

* Spacing = 34-1/2" with 20" & 24" Ø helices.
 ** Maximum Installation Torque rating considers Maximum Driving Stress per ASCE 20.
 *** Structural capacity is shown for galvanized product after 75 years of corrosion. Structural capacity of bare steel product is less due to increased corrosion losses.



156 Circle Freeway Dr.
 Cincinnati, OH 45246
 800-822-7437
www.MagnumPiering.com

MAGNUM® MH3530U Helical Piles

48 Ton Ultimate - 24 Ton Allowable Capacity

High-Strength 3.50" Diameter, 0.30" Wall, Round-Shaft with Rigid Coupler

Description: MAGNUM® Helical Piles offer a number of unique advantages as shown below. MAGNUM® products are manufactured in the USA according to our ISO 9001 approved Quality Program. Our Helical Piles utilize rigid bolted couplings to join extension sections and the lead section, extending the helical bearing plates down to the desired bearing stratum. Structural Capacities are developed according to AISC 360 and ICC-AC308 considering buckling of 5 ft unbraced length after 75 years of corrosion in moderate to high aggressive soils. Various coatings, custom lengths and helix configurations are available upon request. See Magnum Technical Reference Manual for additional information.

1. Round shafts offer increased lateral and buckling resistance compared to square shafts.
2. Patented alternating helix pattern reduces wobble and improves plumbness and tracking.
3. 45-degree miter pilot point aids pile positioning and advancement.
4. Patented MAGNUM® Dual-Cutting Edge helical bearing plates (DCE) enhance penetration through dense soils with occasional cobbles and debris.
5. Sharpened edge on each helix slices through problem soils.
6. Conforming helix shape limits auguring and provides better quality assurance through valid capacity to torque correlations.

Drawing shows an example pile lead and extension section. Section lengths and number of helices vary with project requirements and soil conditions.

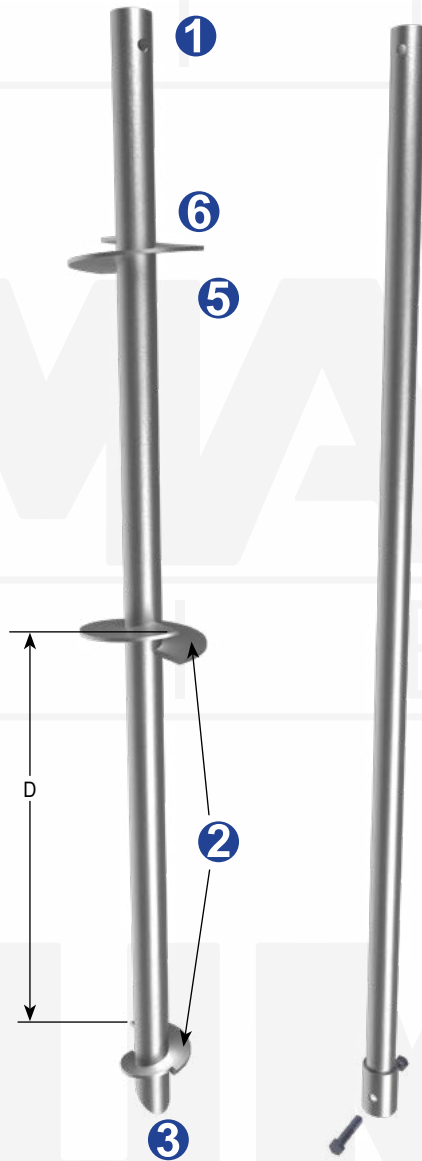
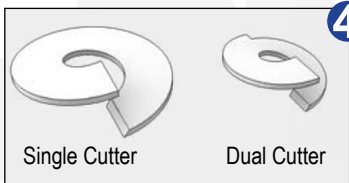

Specifications	
Shaft	3.5" x 0.30" Nominal Pipe ASTM A252, Fy = 80 ksi, or Better
Bolts	(1) 1" Diameter SAE J429 Grade 8 Zinc Coated to ASTM B695/F1941
Helices	3/8" Thick, Helix Die-Pressed ASTM A36, or Better 10", 12", 14", 16", 20 & 24" Diameters Available
Spacing 'D'	* 25-1/2" TYP
Pitch	3"
Coating	Galvanized (G), Bare Steel (NG), Epoxy Powder Coated (EP)
Properties	
7 ft ⁻¹	Ultimate Capacity-to-Torque Ratio
** 13,700 ft-lbs	Maximum Installation Torque
Capacity by Torque	
48 Tons	Ultimate Capacity
24 Tons	Allowable Capacity
Structural Capacity	
*** 48 Tons	Ultimate Capacity
24 Tons	Allowable Capacity

Notes: Helical piles shall be installed to appropriate depth into suitable bearing stratum as determined by geotechnical engineer or local practice. Capacity by torque is based on advancing pile to maximum installation torque. A minimum factor of safety of 2.0 is recommended for determining allowable capacity from correlations with final installation torque. Deflections of 0.5" are typical at allowable capacity; a higher factor of safety may be required to achieve smaller deflections. For tension capacity, helical bearing plates must be deeply embedded (5 ~ 7 x ave. helix diameter or as specified by geotechnical engineer). Load tests are recommended when practical.

* Spacing = 34-1/2" with 20" & 24" Ø helices.

** Maximum Installation Torque rating considers Maximum Driving Stress per ASCE 20.

*** Structural capacity is shown for galvanized product after 75 years of corrosion. Structural capacity of bare steel product is less due to increased corrosion losses.

MAGNUM
PIERING
designed to support

156 Circle Freeway Dr.
Cincinnati, OH 45246
800-822-7437
www.MagnumPiering.com

MAGNUM® MH429U Helical Piles

75 Ton Ultimate - 37 Ton Allowable Capacity

High-Strength 4.50" Diameter, 0.29" Wall, Round-Shaft with Rigid Coupler

Description: MAGNUM® Helical Piles offer a number of unique advantages as shown below. MAGNUM® products are manufactured in the USA according to our ISO 9001 approved Quality Program. Our Helical Piles utilize rigid bolted couplings to join extension sections and the lead section, extending the helical bearing plates down to the desired bearing stratum. Structural Capacities are developed according to AISC 360 and ICC-AC358 considering buckling of 5 ft unbraced length after 75 years of corrosion in moderate to high aggressive soils. Various coatings, custom lengths and helix configurations are available upon request. See Magnum Technical Reference Manual for additional information.

1. Round shafts offer increased lateral and buckling resistance compared to square shafts.
2. Patented alternating helix pattern reduces wobble and improves plumbness and tracking.
3. 45-degree miter pilot point aids pile positioning and advancement.
4. Patented MAGNUM® Dual-Cutting Edge helical bearing plates (DCE) enhance penetration through dense soils with occasional cobbles and debris.
5. Sharpened edge on each helix slices through problem soils.
6. Conforming helix shape limits auguring and provides better quality assurance through valid capacity to torque correlations.

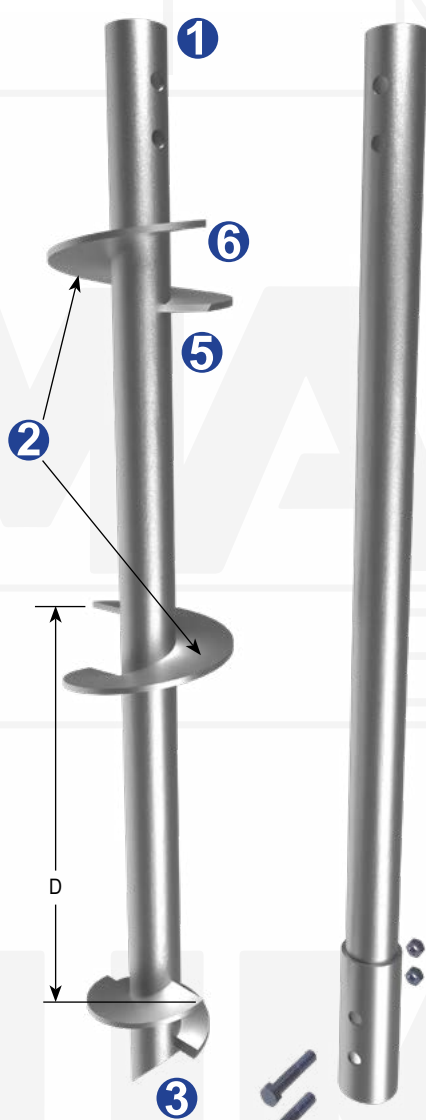

Drawing shows an example pile lead and extension section. Section lengths and number of helices vary with project requirements and soil conditions.

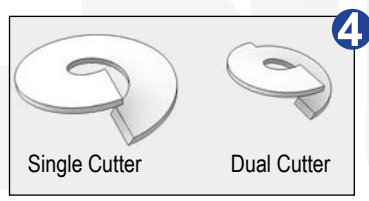

Specifications	
Shaft	4.5" x 0.29" Nominal Pipe ASTM A252, Fy = 80 ksi, or Better
Bolts	(2) 1-1/4" Diameter SAE J429 Grade 5 Zinc Coated to ASTM B695/F1941
Helices	1/2" Thick, Helix Die-Pressed ASTM A36, or Better 10", 12", 14", 16", 20 & 24" Diameters Available
Spacing 'D'	* 31-1/2" TYP
Pitch	3"
Coating	Galvanized (G), Bare Steel (NG), Epoxy Powder Coated (EP)
Properties	
5.7 ft ⁻¹	Ultimate Capacity-to-Torque Ratio
** 26,200 ft-lbs	Maximum Installation Torque
Capacity by Torque	
**** 75 Tons	Ultimate Capacity
37 Tons	Allowable Capacity
Structural Capacity	
*** 91 Tons	Ultimate Capacity
45 Tons	Allowable Capacity

Notes: Helical piles shall be installed to appropriate depth into suitable bearing stratum as determined by geotechnical engineer or local practice. Capacity by torque is based on advancing pile to maximum installation torque. A minimum factor of safety of 2.0 is recommended for determining allowable capacity from correlations with final installation torque. Deflections of 0.5" are typical at allowable capacity; a higher factor of safety may be required to achieve smaller deflections. For tension capacity, helical bearing plates must be deeply embedded (5 ~ 7 x ave. helix diameter or as specified by geotechnical engineer). Load tests are recommended when practical.

* Spacing = 49-1/2" with 20" & 24" Ø helices.
 ** Maximum Installation Torque rating considers Maximum Driving Stress per ASCE 20.
 *** Structural capacity is shown for bare steel product after 75 years of corrosion. Structural capacity of galvanized product is more due to decrease in corrosion losses.
 **** Capacity shown is for multi-helix configurations. For single helix, limit ultimate capacity to 42 Tons.

U.S. Patents 6,058,662, D612,954, Other Patents Pending



156 Circle Freeway Dr.
 Cincinnati, OH 45246
 800-822-7437
www.MagnumPiering.com

MAGNUM® MH429Y Helical Piles

99 Ton Ultimate - 50 Ton Allowable Capacity

High-Strength 4.50" Diameter, 0.29" Wall, Round-Shaft with Rigid Coupler

Description: MAGNUM® Helical Piles offer a number of unique advantages as shown below. MAGNUM® products are manufactured in the USA according to our ISO 9001 approved Quality Program. Our Helical Piles utilize rigid bolted couplings to join extension sections and the lead section, extending the helical bearing plates down to the desired bearing stratum. Structural Capacities are developed according to AISC 360 and ICC-AC358 considering buckling of 5 ft unbraced length after 75 years of corrosion in moderate to high aggressive soils. Various coatings, custom lengths and helix configurations are available upon request. See Magnum Technical Reference Manual for additional information.

1. Round shafts offer increased lateral and buckling resistance compared to square shafts.
2. Patented alternating helix pattern reduces wobble and improves plumbness and tracking.
3. 45-degree miter pilot point aids pile positioning and advancement.
4. Patented MAGNUM® Dual-Cutting Edge helical bearing plates (DCE) enhance penetration through dense soils with occasional cobbles and debris.
5. Sharpened edge on each helix slices through problem soils.
6. Conforming helix shape limits auguring and provides better quality assurance through valid capacity to torque correlations.

Drawing shows an example pile lead and extension section. Section lengths and number of helices vary with project requirements and soil conditions.

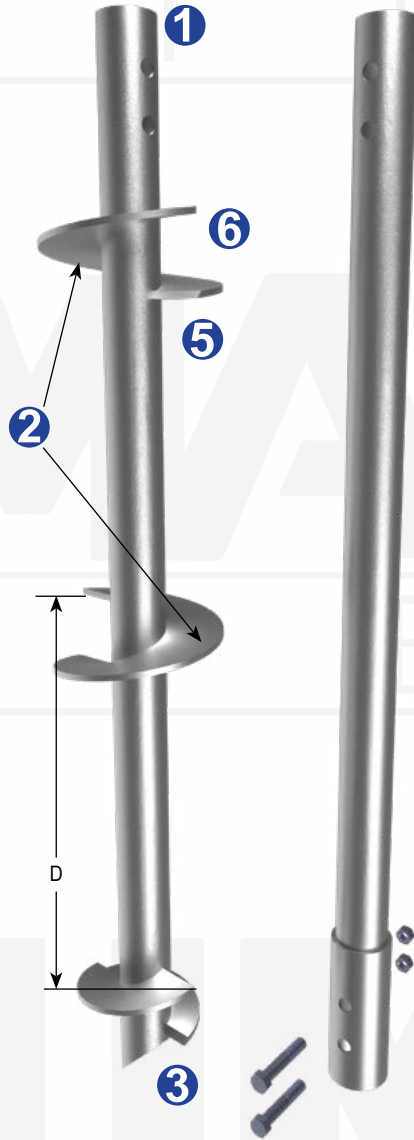
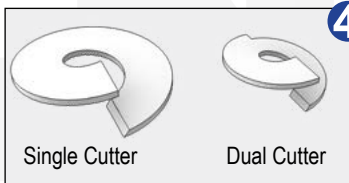

Specifications	
Shaft	4.5" x 0.29" Nominal Pipe ASTM A252, Fy = 110 ksi, or Better
Bolts	(2) 1-1/4" Diameter SAE J429 Grade 5 Zinc Coated to ASTM B695/F1941
Helices	1/2" Thick, Helix Die-Pressed ASTM A36, or Better 10", 12", 14", 16", 20 & 24" Diameters Available
Spacing 'D'	* 31-1/2" TYP
Pitch	3"
Coating	Galvanized (G), Bare Steel (NG), Epoxy Powder Coated (EP)
Properties	
5.7 ft ⁻¹	Ultimate Capacity-to-Torque Ratio
** 34,900 ft-lbs	Maximum Installation Torque
Capacity by Torque	
**** 99 Tons	Ultimate Capacity
50 Tons	Allowable Capacity
Structural Capacity	
*** 120 Tons	Ultimate Capacity
60 Tons	Allowable Capacity

Notes: Helical piles shall be installed to appropriate depth into suitable bearing stratum as determined by geotechnical engineer or local practice. Capacity by torque is based on advancing pile to maximum installation torque. A minimum factor of safety of 2.0 is recommended for determining allowable capacity from correlations with final installation torque. Deflections of 0.5" are typical at allowable capacity; a higher factor of safety may be required to achieve smaller deflections. For tension capacity, helical bearing plates must be deeply embedded (5 ~ 7 x ave. helix diameter or as specified by geotechnical engineer). Load tests are recommended when practical.

* Spacing = 49-1/2" with 20" & 24" Ø helices.

** Maximum Installation Torque rating considers Maximum Driving Stress per ASCE 20.

*** Structural capacity is shown for bare steel product after 75 years of corrosion. Structural capacity of galvanized product is more due to decrease in corrosion losses.

**** Capacity shown is for multi-helix configurations. For single helix, limit ultimate capacity to 42 Tons.

U.S. Patents 6,058,662, D612,954, Other Patents Pending

MAGNUM
PIERING
designed to support

156 Circle Freeway Dr.
Cincinnati, OH 45246
800-822-7437
www.MagnumPiering.com

MAGNUM® MH434U Helical Piles

85 Ton Ultimate - 42.5 Ton Allowable Capacity

High-Strength 4.50" Diameter, 0.337" Wall, Round-Shaft with Rigid Coupler

Description: MAGNUM® Helical Piles offer a number of unique advantages as shown below. MAGNUM® products are manufactured in the USA according to our ISO 9001 approved Quality Program. Our Helical Piles utilize rigid bolted couplings to join extension sections and the lead section, extending the helical bearing plates down to the desired bearing stratum. Structural Capacities are developed according to AISC 360 and ICC-AC358 considering buckling of 5 ft unbraced length after 75 years of corrosion in moderate to high aggressive soils. Various coatings, custom lengths and helix configurations are available upon request. See Magnum Technical Reference Manual for additional information.

1. Round shafts offer increased lateral and buckling resistance compared to square shafts.
2. Patented alternating helix pattern reduces wobble and improves plumbness and tracking.
3. 45-degree miter pilot point aids pile positioning and advancement.
4. Patented MAGNUM® Dual-Cutting Edge helical bearing plates (DCE) enhance penetration through dense soils with occasional cobbles and debris.
5. Sharpened edge on each helix slices through problem soils.
6. Conforming helix shape limits auguring and provides better quality assurance through valid capacity to torque correlations.

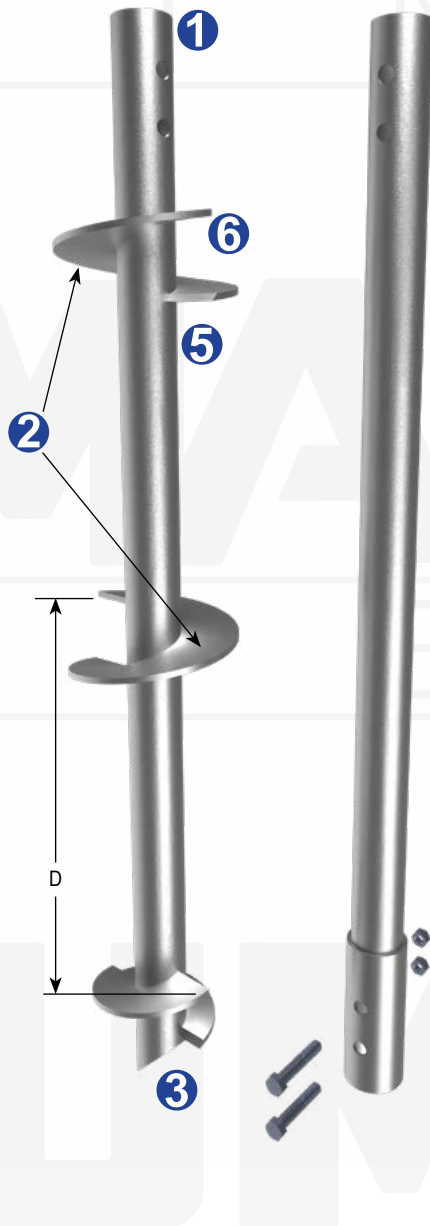

Specifications	
Shaft	4.5" x 0.337" Nominal Pipe ASTM A252, Fy = 80 ksi, or Better
Bolts	(2) 1-1/4" Diameter SAE J429 Grade 5 Zinc Coated to ASTM B695/F1941
Helices	1/2" Thick, Helix Die-Pressed ASTM A36, or Better 10", 12", 14", 16", 20 & 24" Diameters Available
Spacing 'D'	* 31-1/2" TYP
Pitch	3"
Coating	Galvanized (G), Bare Steel (NG), Epoxy Powder Coated (EP)
Properties	
5.7 ft ⁻¹	Ultimate Capacity-to-Torque Ratio
** 29,700 ft-lbs	Maximum Installation Torque
Capacity by Torque	
**** 85 Tons	Ultimate Capacity
42.5 Tons	Allowable Capacity
Structural Capacity	
*** 120 Tons	Ultimate Capacity
60 Tons	Allowable Capacity

Drawing shows an example pile lead and extension section. Section lengths and number of helices vary with project requirements and soil conditions.

Notes: Helical piles shall be installed to appropriate depth into suitable bearing stratum as determined by geotechnical engineer or local practice. Capacity by torque is based on advancing pile to maximum installation torque. A minimum factor of safety of 2.0 is recommended for determining allowable capacity from correlations with final installation torque. Deflections of 0.5" are typical at allowable capacity; a higher factor of safety may be required to achieve smaller deflections. For tension capacity, helical bearing plates must be deeply embedded (5 ~ 7 x ave. helix diameter or as specified by geotechnical engineer). Load tests are recommended when practical.

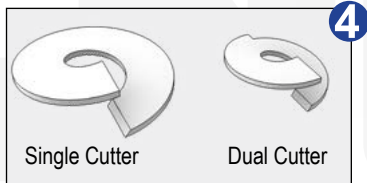

* Spacing = 49-1/2" with 20" & 24" Ø helices.
 ** Maximum Installation Torque rating considers Maximum Driving Stress per ASCE 20.
 *** Structural capacity is shown for bare steel product after 75 years of corrosion. Structural capacity of galvanized product is more due to decrease in corrosion losses.
 **** Capacity shown is for multi-helix configurations. For single helix, limit ultimate capacity to 42 Tons.



156 Circle Freeway Dr.
 Cincinnati, OH 45246
 800-822-7437
www.MagnumPiering.com

MAGNUM® MH434U-6 Helical Piles

73 Ton Ultimate - 36 Ton Allowable Capacity

High-Strength 4.50" Diameter, 0.337" Wall, Round-Shaft with Rigid Coupler

Description: MAGNUM® Helical Piles offer a number of unique advantages as shown below. MAGNUM® products are manufactured in the USA according to our ISO 9001 approved Quality Program. Our Helical Piles utilize rigid bolted couplings to join extension sections and the lead section, extending the helical bearing plates down to the desired bearing stratum. Structural Capacities are developed according to AISC 360 and ICC-AC358 considering buckling of 5 ft unbraced length after 75 years of corrosion in moderate to high aggressive soils. Various coatings, custom lengths and helix configurations are available upon request. See Magnum Technical Reference Manual for additional information.

1. Round shafts offer increased lateral and buckling resistance compared to square shafts.
2. Patented alternating helix pattern reduces wobble and improves plumbness and tracking.
3. 45-degree miter pilot point aids pile positioning and advancement.
4. Patented MAGNUM® Dual-Cutting Edge helical bearing plates (DCE) enhance penetration through dense soils with occasional cobbles and debris.
5. Sharpened edge on each helix slices through problem soils.
6. Conforming helix shape limits auguring and provides better quality assurance through valid capacity to torque correlations.

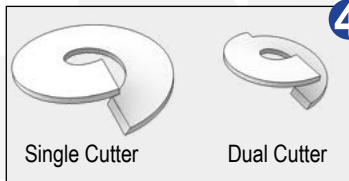
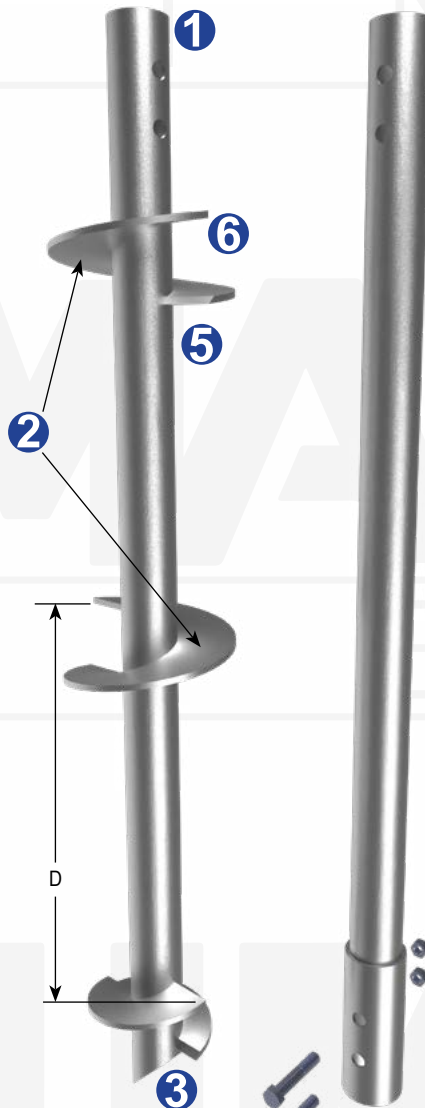

Specifications	
Shaft	4.5" x 0.337" Nominal Pipe ASTM A252, Fy = 80 ksi, or Better
Bolts	(2) 1-1/4" Diameter SAE J429 Grade 5 Zinc Coated to ASTM B695/F1941
Helices	1/2" Thick, Helix Die-Pressed ASTM A36, or Better 10", 12", 14", 16", 20 & 24" Diameters Available
Spacing 'D'	* 33" TYP
Pitch	6"
Coating	Galvanized (G), Bare Steel (NG), Epoxy Powder Coated (EP)
Properties	
4.9 ft ⁻¹	Ultimate Capacity-to-Torque Ratio
** 29,700 ft-lbs	Maximum Installation Torque
Capacity by Torque	
**** 73 Tons	Ultimate Capacity
36 Tons	Allowable Capacity
Structural Capacity	
*** 120 Tons	Ultimate Capacity
60 Tons	Allowable Capacity

Drawing shows an example pile lead and extension section. Section lengths and number of helices vary with project requirements and soil conditions.

Notes: Helical piles shall be installed to appropriate depth into suitable bearing stratum as determined by geotechnical engineer or local practice. Capacity by torque is based on advancing pile to maximum installation torque. A minimum factor of safety of 2.0 is recommended for determining allowable capacity from correlations with final installation torque. Deflections of 0.5" are typical at allowable capacity; a higher factor of safety may be required to achieve smaller deflections. For tension capacity, helical bearing plates must be deeply embedded (5 ~ 7 x ave. helix diameter or as specified by geotechnical engineer). Load tests are recommended when practical.

- * Spacing = 51" with 20" & 24" Ø helices.
- ** Maximum Installation Torque rating considers Maximum Driving Stress per ASCE 20.
- *** Structural capacity is shown for bare steel product after 75 years of corrosion. Structural capacity of galvanized product is more due to decrease in corrosion losses.
- **** Capacity shown is for multi-helix configurations. For single helix, limit ultimate capacity to 42 Tons.

U.S. Patents 6,058,662, D612,954, Other Patents Pending

MAGNUM
PIERING
designed to support

156 Circle Freeway Dr.
Cincinnati, OH 45246
800-822-7437
www.MagnumPiering.com

MAGNUM® MH530Y-6 Helical Piles

135 Ton Ultimate - 68 Ton Allowable Capacity

High-Strength 5.50" Diameter, 0.30" Wall, Round-Shaft with Rigid Coupler

Description: MAGNUM® Helical Piles offer a number of unique advantages as shown below. MAGNUM® products are manufactured in the USA according to our ISO 9001 approved Quality Program. Our Helical Piles utilize rigid bolted couplings to join extension sections and the lead section, extending the helical bearing plates down to the desired bearing stratum. Structural capacities are developed according to AISC 360 and ICC-AC358 considering buckling of 5 ft unbraced length after 75 years of corrosion in moderate to high aggressive soils. Various coatings, custom lengths and helix configurations are available upon request. See Magnum Technical Reference Manual for additional information.

1. Round shafts offer increased lateral and buckling resistance compared to square shafts.
2. Patented alternating helix pattern reduces wobble and improves plumbness and tracking.
3. 45-degree miter pilot point aids pile positioning and advancement.
4. Patented MAGNUM® Dual-Cutting Edge helical bearing plates (DCE) enhance penetration through dense soils with occasional cobbles and debris.
5. Sharpened edge on each helix slices through problem soils.
6. Conforming helix shape limits auguring and provides better quality assurance through valid capacity to torque correlations.

Drawing shows an example pile lead and extension section. Section lengths and number of helices vary with project requirements and soil conditions.

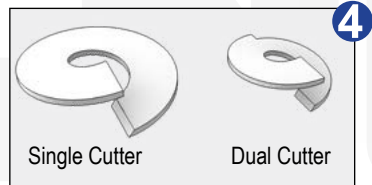
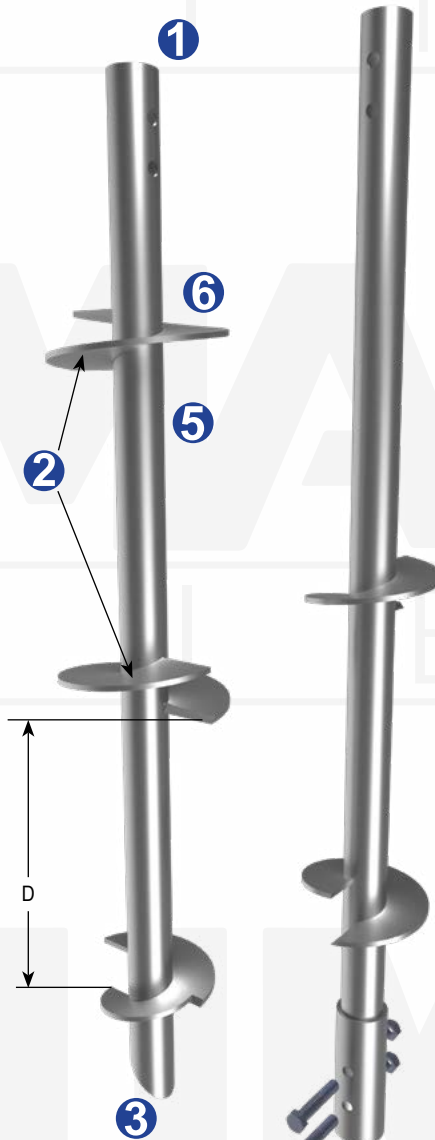

Specifications	
Shaft	5.5" x 0.30" Nominal Pipe ASTM A252, Fy = 110 ksi, or Better
Bolts	(2) 1-1/2" Diameter SAE J429 Grade 5 Zinc Coated to ASTM B695/F 1941
Helices	5/8" Thick, Helix Die-Pressed ASTM A36, or Better 12", 14", 16", 20", 24", 30" & 36" Diame- ters Available
Spacing 'D'	* 39" TYP
Pitch	6"
Coating	Galvanized (G), Bare Steel (NG), Epoxy Powder Coated (EP)
Properties	
4.8 ft ⁻¹	Ultimate Capacity-to-Torque Ratio
** 56,400 ft-lbs	Maximum Installation Torque
Capacity by Torque	
**** 135 Tons	Ultimate Capacity
68 Tons	Allowable Capacity
Structural Capacity	
*** 156 Tons	Ultimate Capacity
78 Tons	Allowable Capacity

Notes: Helical piles shall be installed to appropriate depth into suitable bearing stratum as determined by geotechnical engineer or local practice. Capacity by torque is based on advancing pile to maximum installation torque. A minimum factor of safety of 2.0 is recommended for determining allowable capacity from correlations with final installation torque. Deflections of 0.5" are typical at allowable capacity; a higher factor of safety may be required to achieve smaller deflections. For tension capacity, helical bearing plates must be deeply embedded (5 ~ 7 x ave. helix diameter or as specified by geotechnical engineer). Load tests are recommended when practical.

* Spacing = 69" with 30" & 36" Ø helices.
 ** Maximum Installation Torque rating considers Maximum Driving Stress per ASCE 20.
 *** Structural capacity is shown for bare steel product after 75 years of corrosion.
 Structural capacity of galvanized product is more due to decrease in corrosion losses.
 **** Capacity shown is for multi-helix configurations. For single helix, limit ultimate capacity to 107 Tons.

U.S. Patents 6,058,662, D612,954, Other Patents Pending



156 Circle Freeway Dr.
 Cincinnati, OH 45246
 800-822-7437
www.MagnumPiering.com

MAGNUM® MH536Y-6 Helical Piles

143 Ton Ultimate - 72 Ton Allowable Capacity

High-Strength 5.50" Diameter, 0.36" Wall, Round-Shaft with Rigid Coupler

Description: MAGNUM® Helical Piles offer a number of unique advantages as shown below. MAGNUM® products are manufactured in the USA according to our ISO 9001 approved Quality Program. Our Helical Piles utilize rigid bolted couplings to join extension sections and the lead section, extending the helical bearing plates down to the desired bearing stratum. Structural capacities are developed according to AISC 360 and ICC-AC308 considering buckling of 5 ft unbraced length after 75 years of corrosion in moderate to high aggressive soils. Various coatings, custom lengths and helix configurations are available upon request. See Magnum Technical Reference Manual for additional information.

1. Round shafts offer increased lateral and buckling resistance compared to square shafts.
2. Patented alternating helix pattern reduces wobble and improves plumbness and tracking.
3. 45-degree miter pilot point aids pile positioning and advancement.
4. Patented MAGNUM® Dual-Cutting Edge helical bearing plates (DCE) enhance penetration through dense soils with occasional cobbles and debris.
5. Sharpened edge on each helix slices through problem soils.
6. Conforming helix shape limits auguring and provides better quality assurance through valid capacity to torque correlations.

Drawing shows an example pile lead and extension section. Section lengths and number of helices vary with project requirements and soil conditions.

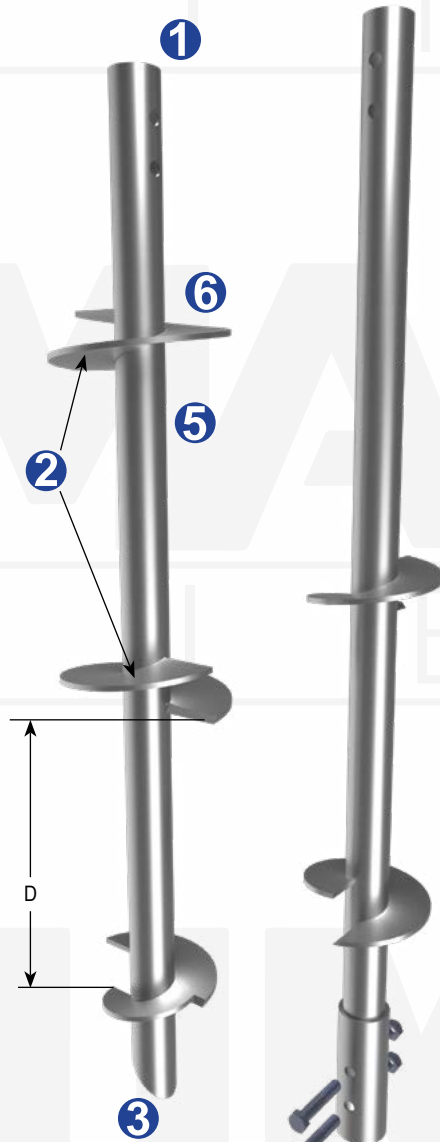
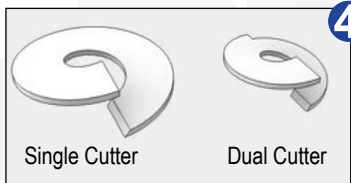

Specifications	
Shaft	5.5" x 0.36" Nominal Pipe ASTM A252, Fy = 110 ksi, or Better
Bolts	(2) 1-1/2" Diameter SAE J429 Grade 5 Zinc Coated to ASTM B695/F1941
Helices	5/8" Thick, Helix Die-Pressed ASTM A36, or Better 12", 14", 16", 20", 24", 30" & 36" Diame- ters Available
Spacing 'D'	* 39" TYP
Pitch	6"
Coating	Galvanized (G), Bare Steel (NG), Epoxy Powder Coated (EP)
Properties	
4.8 ft ⁻¹	Ultimate Capacity-to-Torque Ratio
** 59,700 ft-lbs	Maximum Installation Torque
Capacity by Torque	
**** 143 Tons	Ultimate Capacity
72 Tons	Allowable Capacity
Structural Capacity	
*** 162 Tons	Ultimate Capacity
81 Tons	Allowable Capacity

Notes: Helical piles shall be installed to appropriate depth into suitable bearing stratum as determined by geotechnical engineer or local practice. Capacity by torque is based on advancing pile to maximum installation torque. A minimum factor of safety of 2.0 is recommended for determining allowable capacity from correlations with final installation torque. Deflections of 0.5" are typical at allowable capacity; a higher factor of safety may be required to achieve smaller deflections. For tension capacity, helical bearing plates must be deeply embedded (5 ~ 7 x ave. helix diameter or as specified by geotechnical engineer). Load tests are recommended when practical.

- * Spacing = 69" with 30" and 36" Ø helices.
- ** Maximum Installation Torque rating considers Maximum Driving Stress per ASCE 20.
- *** Structural capacity is shown for bare steel product after 75 years of corrosion. Structural capacity of galvanized product is more due to decrease in corrosion losses.
- **** Capacity shown is for multi-helix configurations. For single helix, limit ultimate capacity to 107 Tons.

U.S. Patents 6,058,662, D612,954, Other Patents Pending

MAGNUM
PIERING
designed to support

156 Circle Freeway Dr.
Cincinnati, OH 45246
800-822-7437
www.MagnumPiering.com

MAGNUM® MH542Y-6 Helical Piles

176 Ton Ultimate - 88 Ton Allowable Capacity

High-Strength 5.50" Diameter, 0.415" Wall, Round-Shaft with Rigid Coupler

Description: MAGNUM® Helical Piles offer a number of unique advantages as shown below. MAGNUM® products are manufactured in the USA according to our ISO 9001 approved Quality Program. Our Helical Piles utilize rigid bolted couplings to join extension sections and the lead section, extending the helical bearing plates down to the desired bearing stratum. Structural capacities are developed according to AISC 360 and ICC-AC358 considering buckling of 5 ft unbraced length after 75 years of corrosion in moderate to high aggressive soils. Various coatings, custom lengths and helix configurations are available upon request. See Magnum Technical Reference Manual for additional information.

1. **Round shafts offer increased lateral and buckling resistance compared to square shafts.**
2. **Patented alternating helix pattern reduces wobble and improves plumbness and tracking.**
3. **45-degree miter pilot point aids pile positioning and advancement.**
4. **Patented MAGNUM® Dual-Cutting Edge helical bearing plates (DCE) enhance penetration through dense soils with occasional cobbles and debris.**
5. **Sharpened edge on each helix slices through problem soils.**
6. **Conforming helix shape limits auguring and provides better quality assurance through valid capacity to torque correlations.**

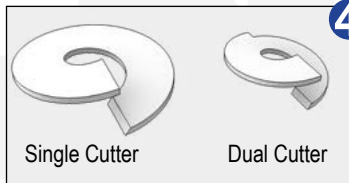
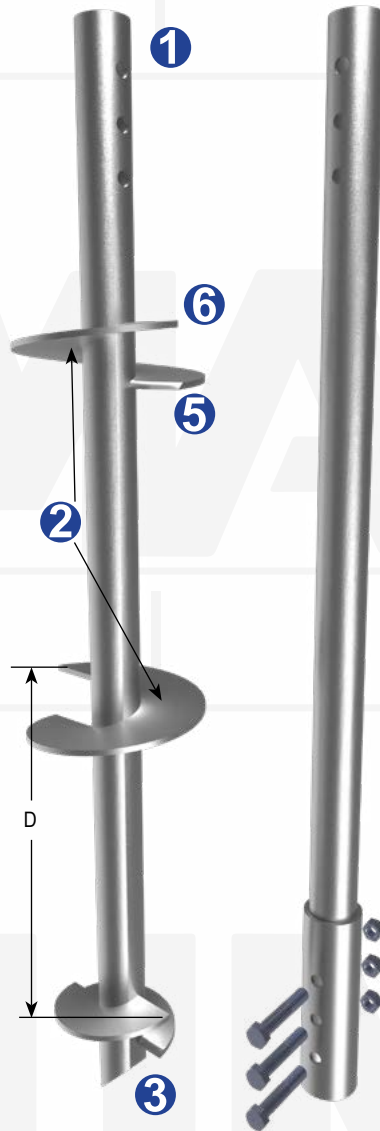

Specifications	
Shaft	5.5" x 0.415" Nominal Pipe ASTM A252, Fy = 110 ksi, or Better
Bolts	(3) 1-1/2" Diameter SAE J429 Grade 5 Zinc Coated to ASTM B695/F1941
Helices	5/8" Thick, Helix Die-Pressed ASTM A36, or Better 12", 14", 16", 20", 24", 30" & 36" Diame- ters Available
Spacing 'D'	* 39" TYP
Pitch	6"
Coating	Galvanized (G), Bare Steel (NG), Epoxy Powder Coated (EP)
Properties	
4.8 ft ⁻¹	Ultimate Capacity-to-Torque Ratio
** 73,400 ft-lbs	Maximum Installation Torque
Capacity by Torque	
**** 176 Tons	Ultimate Capacity
88 Tons	Allowable Capacity
Structural Capacity	
*** 234 Tons	Ultimate Capacity
117 Tons	Allowable Capacity

Drawing shows an example pile lead and extension section. Section lengths and number of helices vary with project requirements and soil conditions.

Notes: Helical piles shall be installed to appropriate depth into suitable bearing stratum as determined by geotechnical engineer or local practice. Capacity by torque is based on advancing pile to maximum installation torque. A minimum factor of safety of 2.0 is recommended for determining allowable capacity from correlations with final installation torque. Deflections of 0.5" are typical at allowable capacity; a higher factor of safety may be required to achieve smaller deflections. For tension capacity, helical bearing plates must be deeply embedded (5 ~ 7 x ave. helix diameter or as specified by geotechnical engineer). Load tests are recommended when practical.

* Spacing = 69" with 30" and 36" Ø helices.
 ** Maximum Installation Torque rating considers Maximum Driving Stress per ASCE 20.
 *** Structural capacity is shown for bare steel product after 75 years of corrosion. Structural capacity of galvanized product is more due to decrease in corrosion losses.
 **** Capacity shown is for multi-helix configurations. For single helix, limit ultimate capacity to 107 Tons.

U.S. Patents 6,058,662, D612,954, Other Patents Pending



156 Circle Freeway Dr.
Cincinnati, OH 45246
800-822-7437
www.MagnumPiering.com

MAGNUM® MH547Y-6 Helical Piles

197 Ton Ultimate - 98 Ton Allowable Capacity

High-Strength 5.50" Diameter, 0.476" Wall, Round-Shaft with Rigid Coupler

Description: MAGNUM® Helical Piles offer a number of unique advantages as shown below. MAGNUM® products are manufactured in the USA according to our ISO 9001 approved Quality Program. Our Helical Piles utilize rigid bolted couplings to join extension sections and the lead section, extending the helical bearing plates down to the desired bearing stratum. Structural capacities are developed according to AISC 360 and ICC-AC358 considering buckling of 5 ft unbraced length after 75 years of corrosion in moderate to high aggressive soils. Various coatings, custom lengths and helix configurations are available upon request. See Magnum Technical Reference Manual for additional information.

1. Round shafts offer increased lateral and buckling resistance compared to square shafts.
2. Patented alternating helix pattern reduces wobble and improves plumbness and tracking.
3. 45-degree miter pilot point aids pile positioning and advancement.
4. Patented MAGNUM® Dual-Cutting Edge helical bearing plates (DCE) enhance penetration through dense soils with occasional cobbles and debris.
5. Sharpened edge on each helix slices through problem soils.
6. Conforming helix shape limits auguring and provides better quality assurance through valid capacity to torque correlations.

Drawing an example pile lead and extension section. Section lengths and number of helices vary with project requirements and soil conditions.

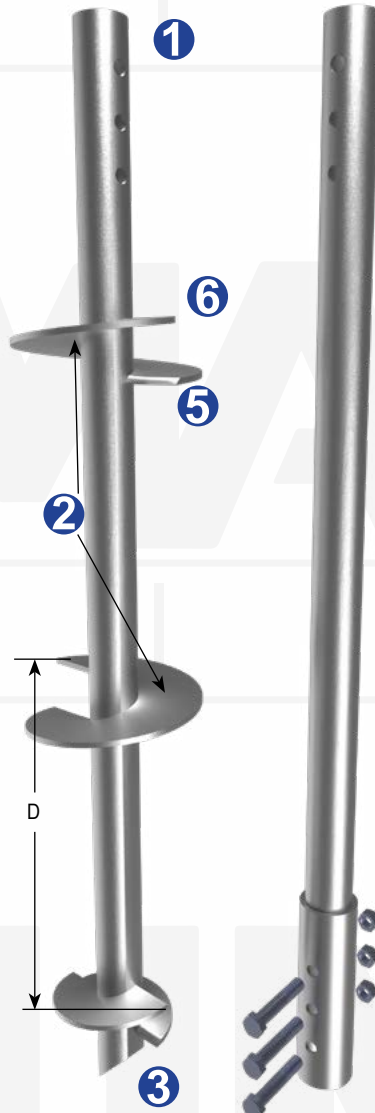
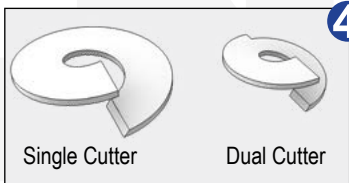

Specifications	
Shaft	5.5" x 0.476" Nominal Pipe ASTM A252, Fy = 110 ksi, or Better
Bolts	(3) 1-1/2" Diameter SAE J429 Grade 5 Zinc Coated to ASTM B695/F1941
Helices	5/8" Thick, Helix Die-Pressed ASTM A36, or Better 12", 14", 16", 20", 24", 30" & 36" Diame- ters Available
Spacing 'D'	* 39" TYP
Pitch	6"
Coating	Galvanized (G), Bare Steel (NG), Epoxy Powder Coated (EP)
Properties	
4.8 ft ⁻¹	Ultimate Capacity-to-Torque Ratio
** 82,000 ft-lbs	Maximum Installation Torque
Capacity by Torque	
**** 197 Tons	Ultimate Capacity
98 Tons	Allowable Capacity
Structural Capacity	
*** 234 Tons	Ultimate Capacity
117 Tons	Allowable Capacity

Notes: Helical piles shall be installed to appropriate depth into suitable bearing stratum as determined by geotechnical engineer or local practice. Capacity by torque is based on advancing pile to maximum installation torque. A minimum factor of safety of 2.0 is recommended for determining allowable capacity from correlations with final installation torque. Deflections of 0.5" are typical at allowable capacity; a higher factor of safety may be required to achieve smaller deflections. For tension capacity, helical bearing plates must be deeply embedded (5 ~ 7 x ave. helix diameter or as specified by geotechnical engineer). Load tests are recommended when practical.

- * Spacing = 69" with 30" and 36" Ø helices.
- ** Maximum Installation Torque rating considers Maximum Driving Stress per ASCE 20.
- *** Structural capacity is shown for bare steel product after 75 years of corrosion. Structural capacity of galvanized product is more due to decrease in corrosion losses.
- **** Capacity shown is for multi-helix configurations. For single helix, limit ultimate capacity to 107 Tons.

U.S. Patents 6,058,662, D612,954, Other Patents Pending

MAGNUM
PIERING
designed to support

156 Circle Freeway Dr.
Cincinnati, OH 45246
800-822-7437
www.MagnumPiering.com

MAGNUM® MH736U-6 Helical Screw Piles

169 Ton Ultimate - 84 Ton Allowable Capacity

High-Strength 7.0" Diameter, 0.36" Wall, Round-Shaft with Rigid Coupler

Description: MAGNUM® Helical Screw Piles offer a number of unique advantages as shown below. MAGNUM® products are manufactured in the USA according to our ISO 9001 approved Quality Program. Our Helical Screw Piles utilize rigid bolted couplings to join extension sections and the lead section, extending the helical bearing plates down to the desired bearing stratum. Structural capacities are developed according to AISC 360 and ICC-AC358 considering buckling of 5 ft unbraced length after 75 years of corrosion in moderate to high aggressive soils. Various coatings, custom lengths and helix configurations are available upon request. See Magnum Technical Reference Manual for additional information.

1. **Round shafts offer increased lateral and buckling resistance compared to square shafts.**
2. **Patented alternating helix pattern reduces wobble and improves plumbness and tracking.**
3. **45-degree miter pilot point aids pile positioning and advancement.**
4. **Patented MAGNUM® Dual-Cutting Edge helical bearing plates (DCE) enhance penetration through dense soils with occasional cobbles and debris.**
5. **Sharpened edge on each helix slices through problem soils.**
6. **Conforming helix shape limits auguring and provides better quality assurance through valid capacity to torque correlations.**

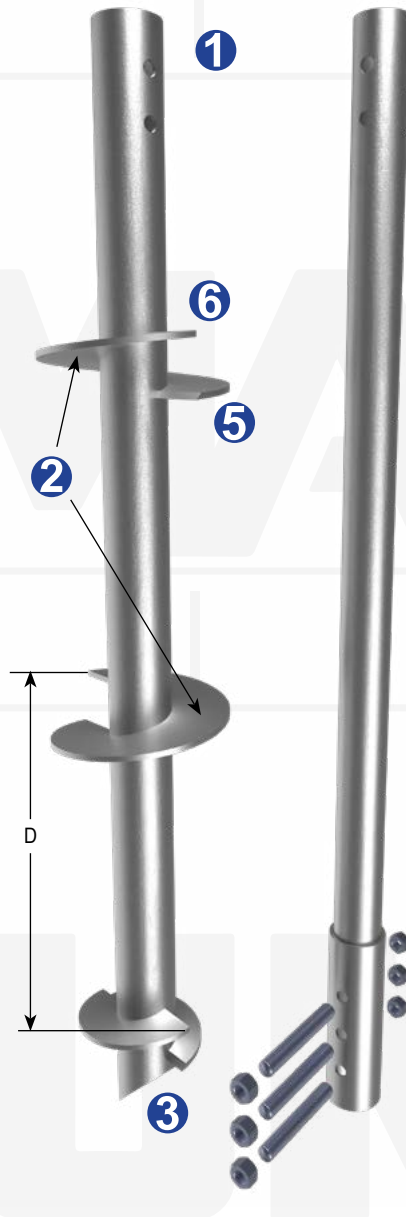

Drawing shows an example pile lead and extension section. Section lengths and number of helices vary with project requirements and soil conditions.

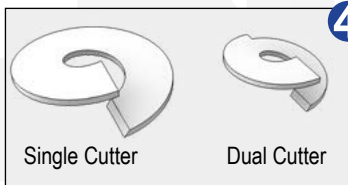

Specifications	
Shaft	7.0" x 0.36" Nominal Pipe ASTM A252, Fy = 80 ksi, or Better
Bolts	(2) 1-1/2" Diameter ASTM A193 B7 Zinc Coated to ASTM B695/F1941
Helices	5/8" Thick, Helix Die-Pressed ASTM A36, or Better 14", 16", 20", 24", 30" & 36" Diameters Available
Spacing 'D'	* 69" TYP
Pitch	6"
Coating	Galvanized (G), Bare Steel (NG), Epoxy Powder Coated (EP)
Properties	
3.9 ft ⁻¹	Ultimate Capacity-to-Torque Ratio
** 86,600 ft-lbs	Maximum Installation Torque
Capacity by Torque	
**** 169 Tons	Ultimate Capacity
84 Tons	Allowable Capacity
Structural Capacity	
*** 247 Tons	Ultimate Capacity
124 Tons	Allowable Capacity

Notes: Helical screw piles shall be installed to appropriate depth into suitable bearing stratum as determined by geotechnical engineer or local practice. Capacity by torque is based on advancing pile to maximum installation torque. A minimum factor of safety of 2.0 is recommended for determining allowable capacity from correlations with final installation torque. Deflections of 0.5" are typical at allowable capacity; a higher factor of safety may be required to achieve smaller deflections. For tension capacity, helical bearing plates must be deeply embedded (5 ~ 7 x ave. helix diameter or as specified by geotechnical engineer). Load tests are recommended when practical.

* Spacing = 87" with 30" & 36" Ø helices.
 ** Maximum Installation Torque rating considers Maximum Driving Stress per ASCE 20.
 *** Structural capacity is shown for bare steel product after 75 years of corrosion. Structural capacity of galvanized product is more due to decrease in corrosion losses.
 **** Capacity shown is for multi-helix configurations. For single helix, limit ultimate capacity to 137 Tons.



156 Circle Freeway Dr.
 Cincinnati, OH 45246
 800-822-7437
www.MagnumPiering.com

MAGNUM® MH740U-6 Helical Screw Piles

187 Ton Ultimate - 94 Ton Allowable Capacity

High-Strength 7.0" Diameter, 0.408" Wall, Round-Shaft with Rigid Coupler

Description: MAGNUM® Helical Screw Piles offer a number of unique advantages as shown below. MAGNUM® products are manufactured in the USA according to our ISO 9001 approved Quality Program. Our Helical Screw Piles utilize rigid bolted couplings to join extension sections and the lead section, extending the helical bearing plates down to the desired bearing stratum. Structural capacities are developed according to AISC 360 and ICC-AC308 considering buckling of 5 ft unbraced length after 75 years of corrosion in moderate to high aggressive soils. Various coatings, custom lengths and helix configurations are available upon request. See Magnum Technical Reference Manual for additional information.

1. Round shafts offer increased lateral and buckling resistance compared to square shafts.
2. Patented alternating helix pattern reduces wobble and improves plumbness and tracking.
3. 45-degree miter pilot point aids pile positioning and advancement.
4. Patented MAGNUM® Dual-Cutting Edge helical bearing plates (DCE) enhance penetration through dense soils with occasional cobbles and debris.
5. Sharpened edge on each helix slices through problem soils.
6. Conforming helix shape limits auguring and provides better quality assurance through valid capacity to torque correlations.

Drawing shows an example pile lead and extension section. Section lengths and number of helices vary with project requirements and soil conditions.

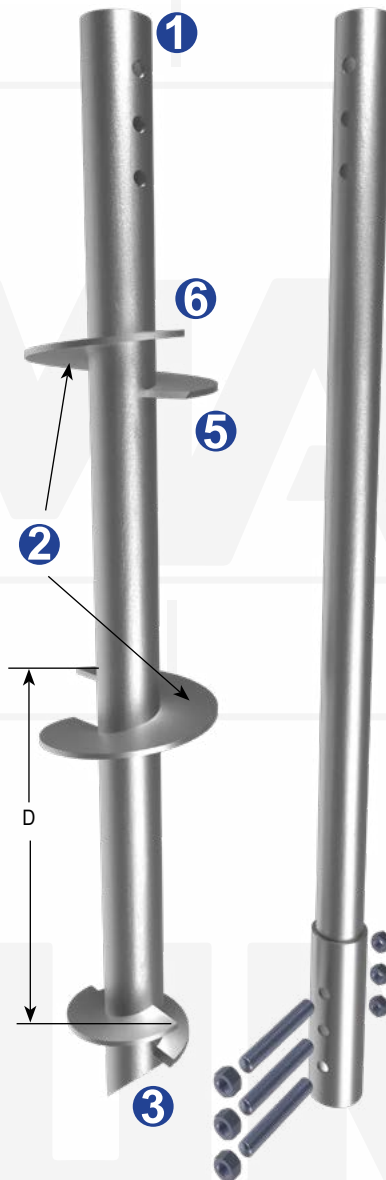
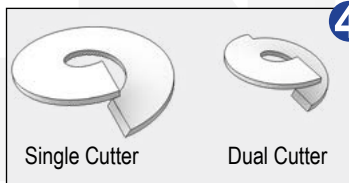

Specifications	
Shaft	7.0" x 0.408" Nominal Pipe ASTM A252, Fy = 80 ksi, or Better
Bolts	(3) 1-1/2" Diameter ASTM A193 B7 Zinc Coated to ASTM B695/F1941
Helices	5/8" Thick, Helix Die-Pressed ASTM A36, or Better 14", 16", 20", 24", 30" & 36" Diameters Available
Spacing 'D'	* 69" TYP
Pitch	6"
Coating	Galvanized (G), Bare Steel (NG), Epoxy Powder Coated (EP)
Properties	
3.9 ft ⁻¹	Ultimate Capacity-to-Torque Ratio
** 96,100 ft-lbs	Maximum Installation Torque
Capacity by Torque	
**** 187 Tons	Ultimate Capacity
94 Tons	Allowable Capacity
Structural Capacity	
*** 252 Tons	Ultimate Capacity
126 Tons	Allowable Capacity

Notes: Helical screw piles shall be installed to appropriate depth into suitable bearing stratum as determined by geotechnical engineer or local practice. Capacity by torque is based on advancing pile to maximum installation torque. A minimum factor of safety of 2.0 is recommended for determining allowable capacity from correlations with final installation torque. Deflections of 0.5" are typical at allowable capacity; a higher factor of safety may be required to achieve smaller deflections. For tension capacity, helical bearing plates must be deeply embedded (5 ~ 7 x ave. helix diameter or as specified by geotechnical engineer). Load tests are recommended when practical.

* Spacing = 87" with 30" & 36" Ø helices.

** Maximum Installation Torque rating considers Maximum Driving Stress per ASCE 20.

*** Structural capacity is shown for bare steel product after 75 years of corrosion.

Structural capacity of galvanized product is more due to decrease in corrosion losses.

**** Capacity shown is for multi-helix configurations. For single helix, limit ultimate capacity to 137 Tons.

U.S. Patents 6,058,662, D612,954, Other Patents Pending

MAGNUM
PIERING
designed to support

156 Circle Freeway Dr.
Cincinnati, OH 45246
800-822-7437
www.MagnumPiering.com

MAGNUM® MH745U-6 Helical Screw Piles

205 Ton Ultimate - 103 Ton Allowable Capacity

High-Strength 7.0" Diameter, 0.453" Wall, Round-Shaft with Rigid Coupler

Description: MAGNUM® Helical Screw Piles offer a number of unique advantages as shown below. MAGNUM® products are manufactured in the USA according to our ISO 9001 approved Quality Program. Our Helical Screw Piles utilize rigid bolted couplings to join extension sections and the lead section, extending the helical bearing plates down to the desired bearing stratum. Structural capacities are developed according to AISC 360 and ICC-AC308 considering buckling of 5 ft unbraced length after 75 years of corrosion in moderate to high aggressive soils. Various coatings, custom lengths and helix configurations are available upon request. See Magnum Technical Reference Manual for additional information.

1. Round shafts offer increased lateral and buckling resistance compared to square shafts.
2. Patented alternating helix pattern reduces wobble and improves plumbness and tracking.
3. 45-degree miter pilot point aids pile positioning and advancement.
4. Patented MAGNUM® Dual-Cutting Edge helical bearing plates (DCE) enhance penetration through dense soils with occasional cobbles and debris.
5. Sharpened edge on each helix slices through problem soils.
6. Conforming helix shape limits auguring and provides better quality assurance through valid capacity to torque correlations.

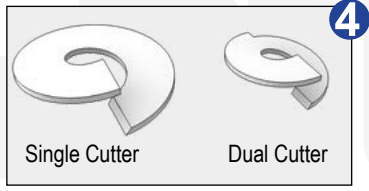
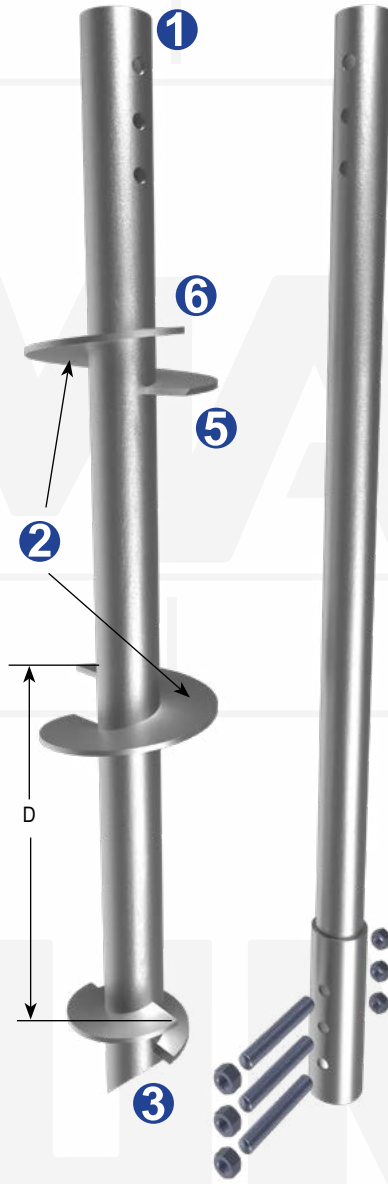

Specifications	
Shaft	7.0" x 0.453" Nominal Pipe ASTM A252, Fy = 80 ksi, or Better
Bolts	(3) 1-1/2" Diameter ASTM A193 B7 Zinc Coated to ASTM B695/F1941
Helices	5/8" Thick, Helix Die-Pressed ASTM A36, or Better 14", 16", 20", 24", 30" & 36" Diameters Available
Spacing 'D'	* 69" TYP
Pitch	6"
Coating	Galvanized (G), Bare Steel (NG), Epoxy Powder Coated (EP)
Properties	
3.9 ft ⁻¹	Ultimate Capacity-to-Torque Ratio
** 105,200 ft-lbs	Maximum Installation Torque
Capacity by Torque	
**** 205 Tons	Ultimate Capacity
103 Tons	Allowable Capacity
Structural Capacity	
*** 280 Tons	Ultimate Capacity
140 Tons	Allowable Capacity

Drawing shows an example pile lead and extension section. Section lengths and number of helices vary with project requirements and soil conditions.

Notes: Helical screw piles shall be installed to appropriate depth into suitable bearing stratum as determined by geotechnical engineer or local practice. Capacity by torque is based on advancing pile to maximum installation torque. A minimum factor of safety of 2.0 is recommended for determining allowable capacity from correlations with final installation torque. Deflections of 0.5" are typical at allowable capacity; a higher factor of safety may be required to achieve smaller deflections. For tension capacity, helical bearing plates must be deeply embedded (5 ~ 7 x ave. helix diameter or as specified by geotechnical engineer). Load tests are recommended when practical.

* Spacing = 87" with 30" & 36" Ø helices.
 ** Maximum Installation Torque rating considers Maximum Driving Stress per ASCE 20.
 *** Structural capacity is shown for bare steel product after 75 years of corrosion. Structural capacity of galvanized product is more due to decrease in corrosion losses.
 **** Capacity shown is for multi-helix configurations. For single helix, limit ultimate capacity to 137 Tons.



156 Circle Freeway Dr.
 Cincinnati, OH 45246
 800-822-7437
www.MagnumPiering.com

U.S. Patents 6,058,662, D612,954, Other Patents Pending

MAGNUM® MH745Y-6 Helical Screw Piles

274 Ton Ultimate - 137 Ton Allowable Capacity

High-Strength 7.0" Diameter, 0.453" Wall, Round-Shaft with Rigid Coupler

Description: MAGNUM® Helical Screw Piles offer a number of unique advantages as shown below. MAGNUM® products are manufactured in the USA according to our ISO 9001 approved Quality Program. Our Helical Screw Piles utilize rigid bolted couplings to join extension sections and the lead section, extending the helical bearing plates down to the desired bearing stratum. Structural capacities are developed according to AISC 360 and ICC-AC308 considering buckling of 5 ft unbraced length after 75 years of corrosion in moderate to high aggressive soils. Various coatings, custom lengths and helix configurations are available upon request. See Magnum Technical Reference Manual for additional information.

- 1. Round shafts offer increased lateral and buckling resistance compared to square shafts.**
- 2. Patented alternating helix pattern reduces wobble and improves plumbness and tracking.**
- 3. 45-degree miter pilot point aids pile positioning and advancement.**
- 4. Patented MAGNUM® Dual-Cutting Edge helical bearing plates (DCE) enhance penetration through dense soils with occasional cobbles and debris.**
- 5. Sharpened edge on each helix slices through problem soils.**
- 6. Conforming helix shape limits auguring and provides better quality assurance through valid capacity to torque correlations.**

Drawing shows an example pile lead and extension section. Section lengths and number of helices vary with project requirements and soil conditions.

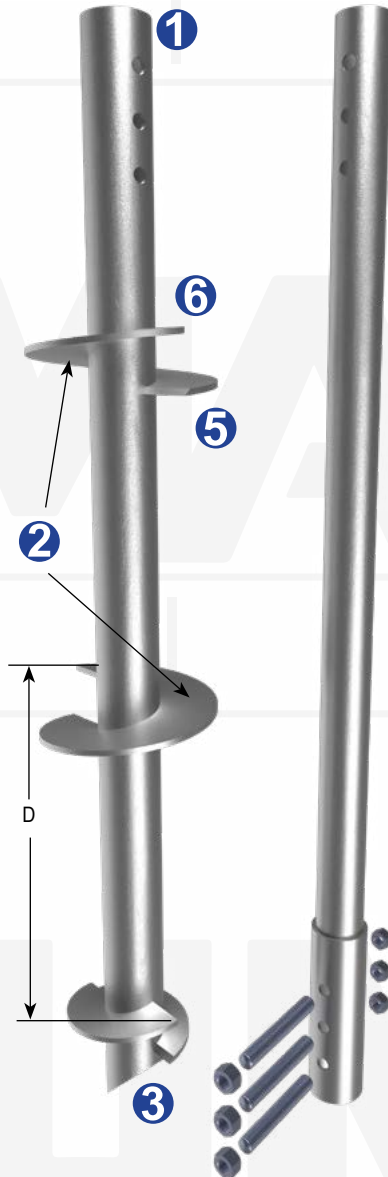
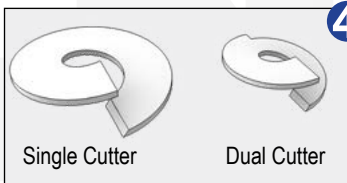

Specifications	
Shaft	7.0" x 0.453" Nominal Pipe ASTM A252, Fy = 110 ksi, or Better
Bolts	(3) 1-1/2" Diameter ASTM A193 B7 Zinc Coated to ASTM B695/F1941
Helices	5/8" Thick, Helix Die-Pressed ASTM A36, or Better 14", 16", 20", 24", 30" & 36" Diameters Available
Spacing 'D'	* 69" TYP
Pitch	6"
Coating	Galvanized (G), Bare Steel (NG), Epoxy Powder Coated (EP)
Properties	
3.9 ft ⁻¹	Ultimate Capacity-to-Torque Ratio
** 140,300 ft-lbs	Maximum Installation Torque
Capacity by Torque	
**** 274 Tons	Ultimate Capacity
137 Tons	Allowable Capacity
Structural Capacity	
*** 280 Tons	Ultimate Capacity
140 Tons	Allowable Capacity

Notes: Helical screw piles shall be installed to appropriate depth into suitable bearing stratum as determined by geotechnical engineer or local practice. Capacity by torque is based on advancing pile to maximum installation torque. A minimum factor of safety of 2.0 is recommended for determining allowable capacity from correlations with final installation torque. Deflections of 0.5" are typical at allowable capacity; a higher factor of safety may be required to achieve smaller deflections. For tension capacity, helical bearing plates must be deeply embedded (5 ~ 7 x ave. helix diameter or as specified by geotechnical engineer). Load tests are recommended when practical.

* Spacing = 87" with 30" & 36" Ø helices.

** Maximum Installation Torque rating considers Maximum Driving Stress per ASCE 20.

*** Structural capacity is shown for bare steel product after 75 years of corrosion.

Structural capacity of galvanized product is more due to decrease in corrosion losses.

**** Capacity shown is for multi-helix configurations. For single helix, limit ultimate capacity to 137 Tons.

U.S. Patents 6,058,662, D612,954, Other Patents Pending

MAGNUM
PIERING
designed to support

156 Circle Freeway Dr.
Cincinnati, OH 45246
800-822-7437
www.MagnumPiering.com

MAGNUM® MH850Q-6 Helical Screw Piles

204 Ton Ultimate - 102 Ton Allowable Capacity

Standard 8.63" Diameter, 0.50" Wall, Round-Shaft with Rigid Coupler

Description: MAGNUM® Helical Screw Piles offer a number of unique advantages as shown below. MAGNUM® products are manufactured in the USA according to our ISO 9001 approved Quality Program. Our Helical Screw Piles utilize rigid bolted couplings to join extension sections and the lead section, extending the helical bearing plates down to the desired bearing stratum. Structural capacities are developed according to AISC 360 and ICC-AC308 considering buckling of 5 ft unbraced length after 75 years of corrosion in moderate to high aggressive soils. Various coatings, custom lengths and helix configurations are available upon request. See Magnum Technical Reference Manual for additional information.

1. Round shafts offer increased lateral and buckling resistance compared to square shafts.
2. Patented alternating helix pattern reduces wobble and improves plumbness and tracking.
3. 45-degree miter pilot point aids pile positioning and advancement.
4. Patented MAGNUM® Dual-Cutting Edge helical bearing plates (DCE) enhance penetration through dense soils with occasional cobbles and debris.
5. Sharpened edge on each helix slices through problem soils.
6. Conforming helix shape limits auguring and provides better quality assurance through valid capacity to torque correlations.

Drawing shows an example pile lead and extension section. Section lengths and number of helices vary with project requirements and soil conditions.

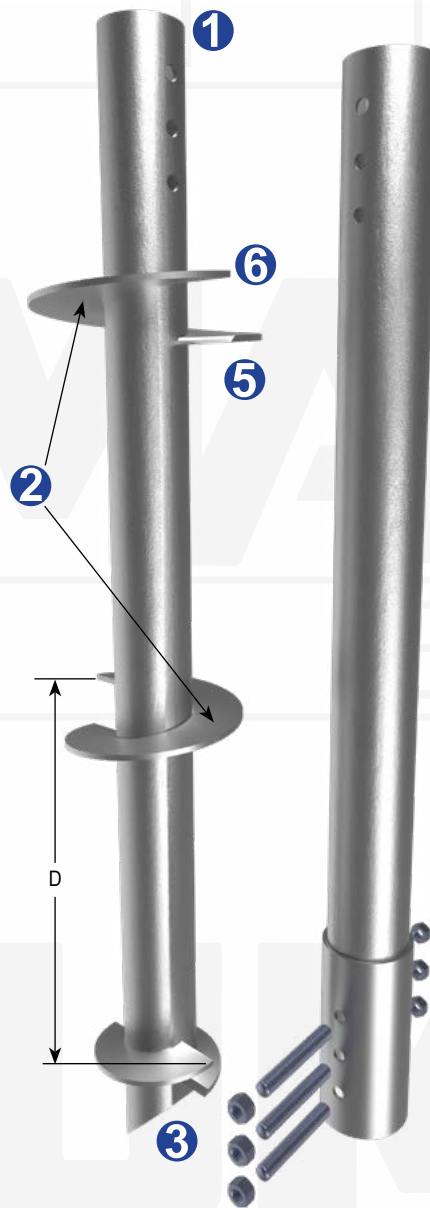
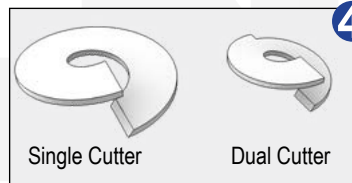

Specifications	
Shaft	8.63" x 0.5" Nominal Pipe ASTM A252, Fy = 50 ksi, or Better
Bolts	(3) 1-1/2" Diameter ASTM A193 B7 Zinc Coated to ASTM B695/F1941
Helices	5/8" Thick, Helix Die-Pressed ASTM A36, or Better 16", 20", 24", 30", 36" & 42" Diameters Available
Spacing 'D'	* 69" TYP
Pitch	6"
Coating	Galvanized (G), Bare Steel (NG), Epoxy Powder Coated (EP)
Properties	
3.3 ft ⁻¹	Ultimate Capacity-to-Torque Ratio
** 123,500 ft-lbs	Maximum Installation Torque
Capacity by Torque	
**** 204 Tons	Ultimate Capacity
102 Tons	Allowable Capacity
Structural Capacity	
*** 261 Tons	Ultimate Capacity
131 Tons	Allowable Capacity

Notes: Helical screw piles shall be installed to appropriate depth into suitable bearing stratum as determined by geotechnical engineer or local practice. Capacity by torque is based on advancing pile to maximum installation torque. A minimum factor of safety of 2.0 is recommended for determining allowable capacity from correlations with final installation torque. Deflections of 0.5" are typical at allowable capacity; a higher factor of safety may be required to achieve smaller deflections. For tension capacity, helical bearing plates must be deeply embedded (5 ~ 7 x ave. helix diameter or as specified by geotechnical engineer). Load tests are recommended when practical.

* Spacing = 87" with 30", 36" & 42" Ø helices.
 ** Maximum Installation Torque rating considers Maximum Driving Stress per ASCE 20.
 *** Structural capacity is shown for bare steel product after 75 years of corrosion. Structural capacity of galvanized product is more due to decrease in corrosion losses.
 **** Capacity shown is for multi-helix configurations. For single helix, limit ultimate capacity to 168 Tons.



156 Circle Freeway Dr.
Cincinnati, OH 45246
800-822-7437
www.MagnumPiering.com

MAGNUM® MH939U-6 Helical Screw Piles

220 Ton Ultimate - 110 Ton Allowable Capacity

High-Strength 9.63" Diameter, 0.39" Wall, Round-Shaft with Rigid Coupler

Description: MAGNUM® Helical Screw Piles offer a number of unique advantages as shown below. MAGNUM® products are manufactured in the USA according to our ISO 9001 approved Quality Program. Our Helical Screw Piles utilize rigid bolted couplings to join extension sections and the lead section, extending the helical bearing plates down to the desired bearing stratum. Structural capacities are developed according to AISC 360 and ICC-AC308 considering buckling of 5 ft unbraced length after 75 years of corrosion in moderate to high aggressive soils. Various coatings, custom lengths and helix configurations are available upon request. See Magnum Technical Reference Manual for additional information.

1. Round shafts offer increased lateral and buckling resistance compared to square shafts.
2. Patented alternating helix pattern reduces wobble and improves plumbness and tracking.
3. 45-degree miter pilot point aids pile positioning and advancement.
4. Patented MAGNUM® Dual-Cutting Edge helical bearing plates (DCE) enhance penetration through dense soils with occasional cobbles and debris.
5. Sharpened edge on each helix slices through problem soils.
6. Conforming helix shape limits auguring and provides better quality assurance through valid capacity to torque correlations.

Drawing shows an example pile lead and extension section. Section lengths and number of helices vary with project requirements and soil conditions.

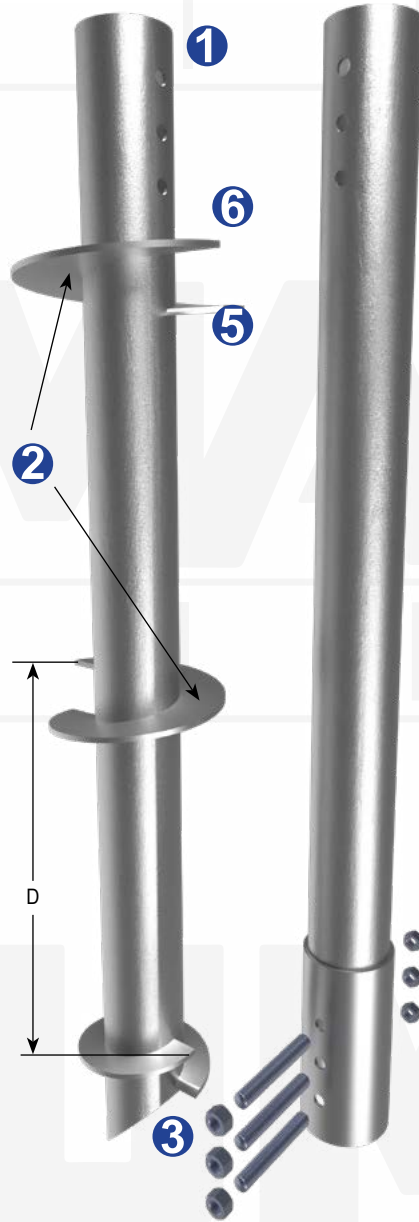
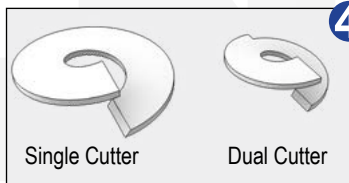

Specifications	
Shaft	9.63" x 0.39" Nominal Pipe ASTM A252, Fy = 80 ksi, or Better
Bolts	(3) 1-1/2" Diameter ASTM A193 B7 Zinc Coated to ASTM B695/F1941
Helices	5/8" Thick, Helix Die-Pressed ASTM A36, or Better 16", 20", 24", 30", 36" & 42" Diameters Available
Spacing 'D'	* 69" TYP
Pitch	6"
Coating	Galvanized (G), Bare Steel (NG), Epoxy Powder Coated (EP)
Properties	
3.0 ft ⁻¹	Ultimate Capacity-to-Torque Ratio
** 146,300 ft-lbs	Maximum Installation Torque
Capacity by Torque	
**** 220 Tons	Ultimate Capacity
110 Tons	Allowable Capacity
Structural Capacity	
*** 220 Tons	Ultimate Capacity
110 Tons	Allowable Capacity

Notes: Helical screw piles shall be installed to appropriate depth into suitable bearing stratum as determined by geotechnical engineer or local practice. Capacity by torque is based on advancing pile to maximum installation torque. A minimum factor of safety of 2.0 is recommended for determining allowable capacity from correlations with final installation torque. Deflections of 0.5" are typical at allowable capacity; a higher factor of safety may be required to achieve smaller deflections. For tension capacity, helical bearing plates must be deeply embedded (5 ~ 7 x ave. helix diameter or as specified by geotechnical engineer). Load tests are recommended when practical.

* Spacing = 87" with 30", 36" & 42" Ø helices.
 ** Maximum Installation Torque rating considers Maximum Driving Stress per ASCE 20.
 *** Structural capacity is shown for bare steel product after 75 years of corrosion. Structural capacity of galvanized product is more due to decrease in corrosion losses.
 **** Capacity shown is for multi-helix configurations. For single helix, limit ultimate capacity to 125 Tons.

U.S. Patents 6,058,662, D612,954, Other Patents Pending



156 Circle Freeway Dr.
Cincinnati, OH 45246
800-822-7437
www.MagnumPiering.com

MAGNUM® MH1050U-6 Helical Screw Piles

410 Ton Ultimate - 205 Ton Allowable Capacity

High-Strength 10.75" Diameter, 0.5" Wall, Round-Shaft with Rigid Coupler

Description: MAGNUM® Helical Screw Piles offer a number of unique advantages as shown below. MAGNUM® products are manufactured in the USA according to our ISO 9001 approved Quality Program. Our Helical Screw Piles utilize rigid bolted couplings to join extension sections and the lead section, extending the helical bearing plates down to the desired bearing stratum. Structural capacities are developed according to AISC 360 and ICC-AC308 considering buckling of 5 ft unbraced length after 75 years of corrosion in moderate to high aggressive soils. Various coatings, custom lengths and helix configurations are available upon request. See Magnum Technical Reference Manual for additional information.

1. Round shafts offer increased lateral and buckling resistance compared to square shafts.
2. Patented alternating helix pattern reduces wobble and improves plumbness and tracking.
3. 45-degree miter pilot point aids pile positioning and advancement.
4. Patented MAGNUM® Dual-Cutting Edge helical bearing plates (DCE) enhance penetration through dense soils with occasional cobbles and debris.
5. Sharpened edge on each helix slices through problem soils.
6. Conforming helix shape limits auguring and provides better quality assurance through valid capacity to torque correlations.

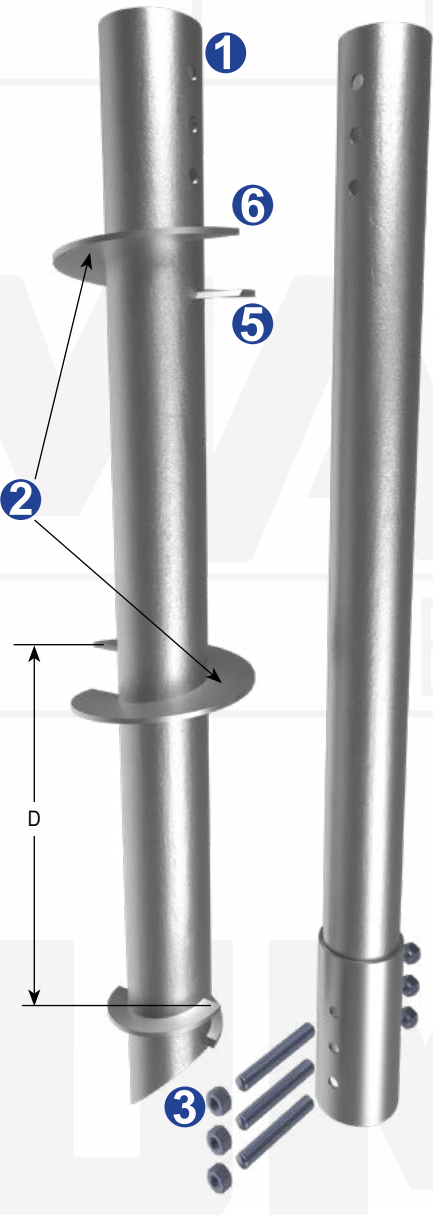

Specifications	
Shaft	10.75" x 0.50" Nominal Pipe ASTM A252, Fy = 80 ksi, or Better
Bolts	(3) 2" Diameter ASTM A193 B7 Zinc Coated to ASTM B695/F1941
Helices	1" Thick, Helix Die-Pressed ASTM A36, or Better 20", 24", 30", 36" & 42" Diameters Available
Spacing 'D'	* 69" TYP
Pitch	6"
Coating	Galvanized (G), Bare Steel (NG), Epoxy Powder Coated (EP)
Properties	
2.8 ft ⁻¹	Ultimate Capacity-to-Torque Ratio
** 293,200 ft-lbs	Maximum Installation Torque
Capacity by Torque	
**** 410 Tons	Ultimate Capacity
205 Tons	Allowable Capacity
Structural Capacity	
*** 504 Tons	Ultimate Capacity
252 Tons	Allowable Capacity

Drawing shows an example pile lead and extension section. Section lengths and number of helices vary with project requirements and soil conditions.

Notes: Helical screw piles shall be installed to appropriate depth into suitable bearing stratum as determined by geotechnical engineer or local practice. Capacity by torque is based on advancing pile to maximum installation torque. A minimum factor of safety of 2.0 is recommended for determining allowable capacity from correlations with final installation torque. Deflections of 0.5" are typical at allowable capacity; a higher factor of safety may be required to achieve smaller deflections. For tension capacity, helical bearing plates must be deeply embedded (5 ~ 7 x ave. helix diameter or as specified by geotechnical engineer). Load tests are recommended when practical.

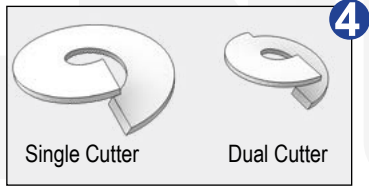

* Spacing = 87" with 30", 36" & 42" Ø helices.
 ** Maximum Installation Torque rating considers Maximum Driving Stress per ASCE 20.
 *** Structural capacity is shown for bare steel product after 75 years of corrosion.
 Structural capacity of galvanized product is more due to decrease in corrosion losses.
 **** Capacity shown is for multi-helix configurations. For single helix, limit ultimate capacity to 346 Tons.



156 Circle Freeway Dr.
 Cincinnati, OH 45246
 800-822-7437
 www.MagnumPiering.com

MAGNUM[®] MH1250Q-6 Helical Screw Piles

280 Ton Ultimate - 140 Ton Allowable Capacity

Standard 12.75" Diameter, 0.50" Wall, Round-Shaft with Rigid Coupler

Description: MAGNUM[®] Helical Screw Piles offer a number of unique advantages as shown below. MAGNUM[®] products are manufactured in the USA according to our ISO 9001 approved Quality Program. Our Helical Screw Piles utilize rigid bolted couplings to join extension sections and the lead section, extending the helical bearing plates down to the desired bearing stratum. Structural capacities are developed according to AISC 360 and ICC-AC308 considering buckling of 5 ft unbraced length after 75 years of corrosion in moderate to high aggressive soils. Various coatings, custom lengths and helix configurations are available upon request. See Magnum Technical Reference Manual for additional information.

1. Round shafts offer increased lateral and buckling resistance compared to square shafts.
2. Patented alternating helix pattern reduces wobble and improves plumbness and tracking.
3. 45-degree miter pilot point aids pile positioning and advancement.
4. Patented MAGNUM[®] Dual-Cutting Edge helical bearing plates (DCE) enhance penetration through dense soils with occasional cobbles and debris.
5. Sharpened edge on each helix slices through problem soils.
6. Conforming helix shape limits auguring and provides better quality assurance through valid capacity to torque correlations.

Drawing shows an example pile lead and extension section. Section lengths and number of helices vary with project requirements and soil conditions.

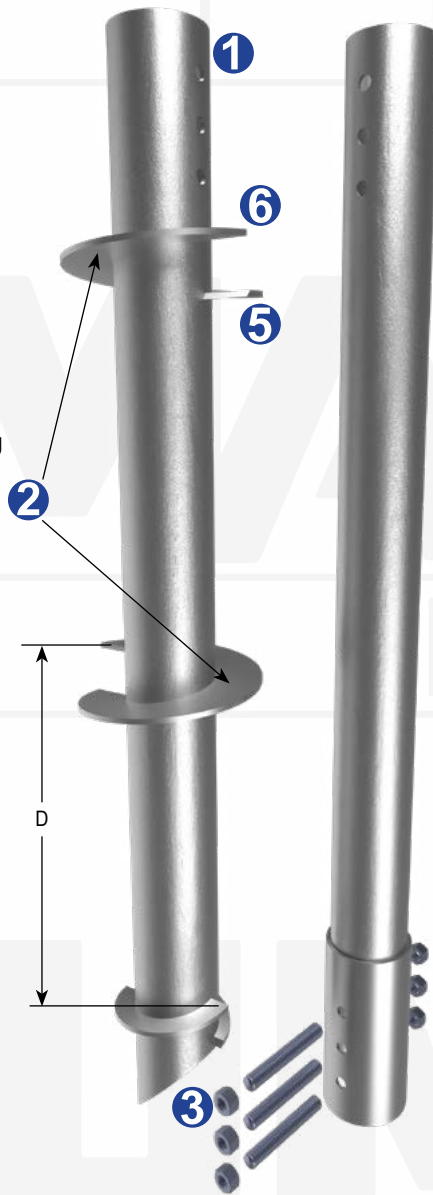
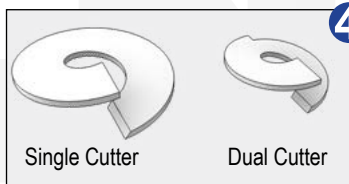

Specifications	
Shaft	12.75" x 0.5" Nominal Pipe ASTM A252, Fy = 50 ksi, or Better
Bolts	(3) 1-1/2" Diameter ASTM A193 B7 Zinc Coated to ASTM B695/F1941
Helices	5/8" Thick, Helix Die-Pressed ASTM A36, or Better 18", 20", 24", 30", 36" & 42" Diameters Available
Spacing 'D'	* 69" TYP
Pitch	6"
Coating	Galvanized (G), Bare Steel (NG), Epoxy Powder Coated (EP)
Properties	
2.4 ft ⁻¹	Ultimate Capacity-to-Torque Ratio
** 233,000 ft-lbs	Maximum Installation Torque
Capacity by Torque	
280 Tons	Ultimate Capacity
140 Tons	Allowable Capacity
Structural Capacity	
*** 280.Tons	Ultimate Capacity
140 Tons	Allowable Capacity

Notes: Helical screw piles shall be installed to appropriate depth into suitable bearing stratum as determined by geotechnical engineer or local practice. Capacity by torque is based on advancing pile to maximum installation torque. A minimum factor of safety of 2.0 is recommended for determining allowable capacity from correlations with final installation torque. Deflections of 0.5" are typical at allowable capacity; a higher factor of safety may be required to achieve smaller deflections. For tension capacity, helical bearing plates must be deeply embedded (5 ~ 7 x ave. helix diameter or as specified by geotechnical engineer). Load tests are recommended when practical.

* Spacing = 87" with 30", 36" & 42" Ø helices.

** Maximum Installation Torque rating considers Maximum Driving Stress per ASCE 20.

*** Structural capacity is shown for bare steel product after 75 years of corrosion.

Structural capacity of galvanized product is more due to decrease in corrosion losses.

MAGNUM[®]
PIERING
designed to support

156 Circle Freeway Dr.
Cincinnati, OH 45246
800-822-7437
www.MagnumPiering.com

U.S. Patents 6,058,662, D612,954, Other Patents Pending

MAGNUM[®] MH1338Q-6 Helical Screw Piles

233 Ton Ultimate - 116 Ton Allowable Capacity

Standard 13.38" Diameter, 0.38" Wall, Round-Shaft with Rigid Coupler

Description: MAGNUM[®] Helical Screw Piles offer a number of unique advantages as shown below. MAGNUM[®] products are manufactured in the USA according to our ISO 9001 approved Quality Program. Our Helical Screw Piles utilize rigid bolted couplings to join extension sections and the lead section, extending the helical bearing plates down to the desired bearing stratum. Structural capacities are developed according to AISC 360 and ICC-AC308 considering buckling of 5 ft unbraced length after 75 years of corrosion in moderate to high aggressive soils. Various coatings, custom lengths and helix configurations are available upon request. See Magnum Technical Reference Manual for additional information.

1. Round shafts offer increased lateral and buckling resistance compared to square shafts.
2. Patented alternating helix pattern reduces wobble and improves plumbness and tracking.
3. 45-degree miter pilot point aids pile positioning and advancement.
4. Patented MAGNUM[®] Dual-Cutting Edge helical bearing plates (DCE) enhance penetration through dense soils with occasional cobbles and debris.
5. Sharpened edge on each helix slices through problem soils.
6. Conforming helix shape limits auguring and provides better quality assurance through valid capacity to torque correlations.

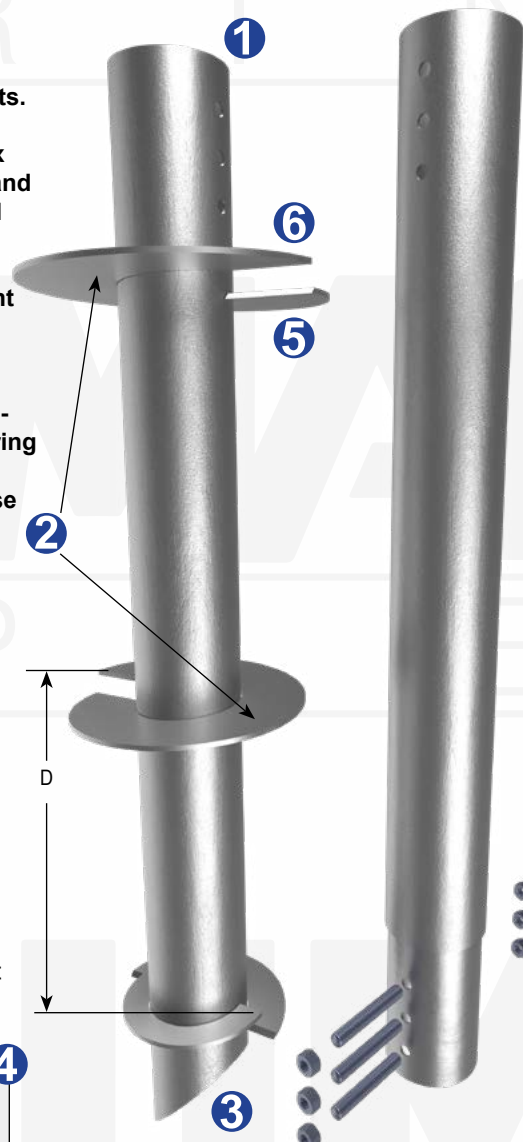

Specifications	
Shaft	13.375" x 0.375" Nominal Pipe ASTM A252, Fy = 50 ksi, or Better
Bolts	(3) 1-1/2" Diameter ASTM A193 B7 Zinc Coated to ASTM B695/F1941
Helices	5/8" Thick, Helix Die-Pressed ASTM A36, or Better 18", 20", 24", 30", 36" & 42" Diameters Available
Spacing 'D'	* 69" TYP
Pitch	6"
Coating	Galvanized (G), Bare Steel (NG), Epoxy Powder Coated (EP)
Properties	
2.4 ft ⁻¹	Ultimate Capacity-to-Torque Ratio
** 194,200 ft-lbs	Maximum Installation Torque
Capacity by Torque	
233Tons	Ultimate Capacity
116 Tons	Allowable Capacity
Structural Capacity	
*** 233 Tons	Ultimate Capacity
116 Tons	Allowable Capacity

Drawing shows an example pile lead and extension section. Section lengths and number of helices vary with project requirements and soil conditions.

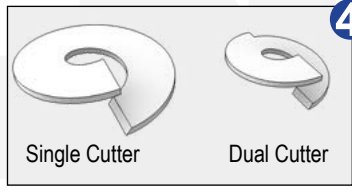

Notes: Helical screw piles shall be installed to appropriate depth into suitable bearing stratum as determined by geotechnical engineer or local practice. Capacity by torque is based on advancing pile to maximum installation torque. A minimum factor of safety of 2.0 is recommended for determining allowable capacity from correlations with final installation torque. Deflections of 0.5" are typical at allowable capacity; a higher factor of safety may be required to achieve smaller deflections. For tension capacity, helical bearing plates must be deeply embedded (5 ~ 7 x ave. helix diameter or as specified by geotechnical engineer). Load tests are recommended when practical.

* Spacing = 87" with 30", 36" & 42" Ø helices.
 ** Maximum Installation Torque rating considers Maximum Driving Stress per ASCE 20.
 *** Structural capacity is shown for galvanized steel product after 75 years of corrosion. Structural capacity of bare steel product is less due to increase in corrosion losses.



156 Circle Freeway Dr.
 Cincinnati, OH 45246
 800-822-7437
www.MagnumPiering.com

U.S. Patents 6,058,662, D612,954, Other Patents Pending

MAGNUM® MH1650U-6 Helical Screw Piles

280 Ton Ultimate - 140 Ton Allowable Capacity

Standard 16.0" Diameter, 0.495" Wall, Round-Shaft with Rigid Coupler

Description: MAGNUM® Helical Screw Piles offer a number of unique advantages as shown below. MAGNUM® products are manufactured in the USA according to our ISO 9001 approved Quality Program. Our Helical Screw Piles utilize rigid bolted couplings to join extension sections and the lead section, extending the helical bearing plates down to the desired bearing stratum. Structural capacities are developed according to AISC 360 and ICC-AC308 considering buckling of 5 ft unbraced length after 75 years of corrosion in moderate to high aggressive soils. Various coatings, custom lengths and helix configurations are available upon request. See Magnum Technical Reference Manual for additional information.

1. Round shafts offer increased lateral and buckling resistance compared to square shafts.
2. Patented alternating helix pattern reduces wobble and improves plumbness and tracking.
3. 45-degree miter pilot point aids pile positioning and advancement.
4. Patented MAGNUM® Dual-Cutting Edge helical bearing plates (DCE) enhance penetration through dense soils with occasional cobbles and debris.
5. Sharpened edge on each helix slices through problem soils.
6. Conforming helix shape limits auguring and provides better quality assurance through valid capacity to torque correlations.

Drawing shows an example pile lead and extension section. Section lengths and number of helices vary with project requirements and soil conditions.

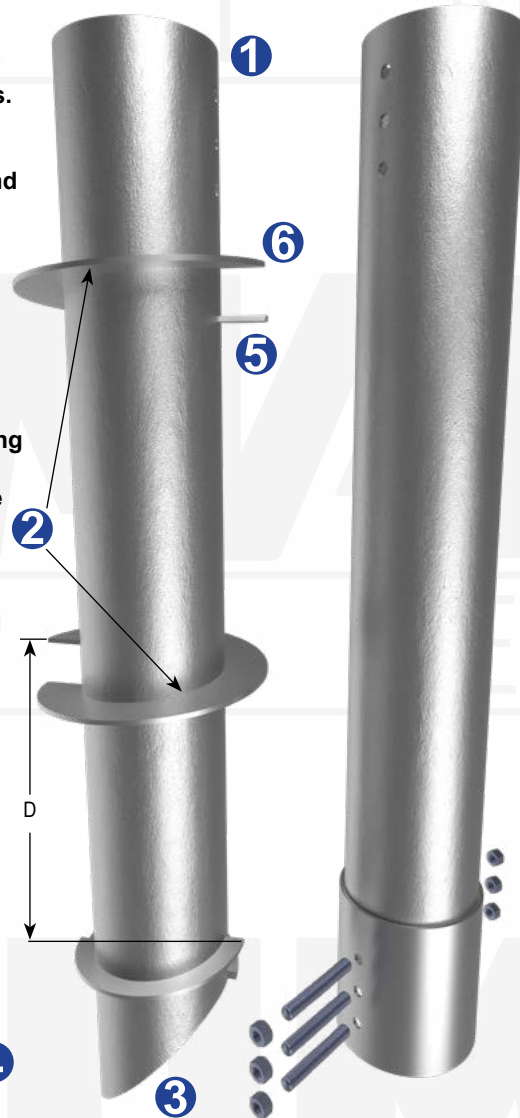
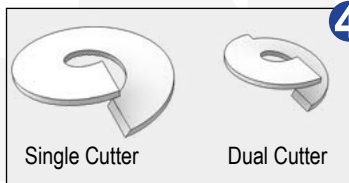

Specifications	
Shaft	16.0" x 0.495" Nominal Pipe ASTM A252, Fy = 80 ksi, or Better
Bolts	(3) 1-1/2" Diameter ASTM A193 B7 Zinc Coated to ASTM B695/F1941
Helices	5/8" Thick, Helix Die-Pressed ASTM A36, or Better 20", 24", 30", 36" & 42" Diameters Available
Spacing 'D'	* 69" TYP
Pitch	6"
Coating	Galvanized (G), Bare Steel (NG), Epoxy Powder Coated (EP)
Properties	
2.1 ft ⁻¹	Ultimate Capacity-to-Torque Ratio
** 265,700 ft-lbs	Maximum Installation Torque
Capacity by Torque	
280 Tons	Ultimate Capacity
140 Tons	Allowable Capacity
Structural Capacity	
*** 280 Tons	Ultimate Capacity
140 Tons	Allowable Capacity

Notes: Helical screw piles shall be installed to appropriate depth into suitable bearing stratum as determined by geotechnical engineer or local practice. Capacity by torque is based on advancing pile to maximum installation torque. A minimum factor of safety of 2.0 is recommended for determining allowable capacity from correlations with final installation torque. Deflections of 0.5" are typical at allowable capacity; a higher factor of safety may be required to achieve smaller deflections. For tension capacity, helical bearing plates must be deeply embedded (5 ~ 7 x ave. helix diameter or as specified by geotechnical engineer). Load tests are recommended when practical.

* Spacing = 87" with 30", 36" & 42" Ø helices.

** Maximum Installation Torque rating considers Maximum Driving Stress per ASCE 20.

*** Structural capacity is shown for bare steel product after 75 years of corrosion. Structural capacity of galvanized product is more due to decrease in corrosion losses.

MAGNUM
PIERING
designed to support

156 Circle Freeway Dr.
Cincinnati, OH 45246
800-822-7437
www.MagnumPiering.com

U.S. Patents 6,058,662, D612,954, Other Patents Pending

MAGNUM® MH1843Q-6 Helical Screw Piles

267 Ton Ultimate - 134 Ton Allowable Capacity

Standard 18.63" Diameter, 0.43" Wall, Round-Shaft with Rigid Coupler

Description: MAGNUM® Helical Screw Piles offer a number of unique advantages as shown below. MAGNUM® products are manufactured in the USA according to our ISO 9001 approved Quality Program. Our Helical Screw Piles utilize rigid bolted couplings to join extension sections and the lead section, extending the helical bearing plates down to the desired bearing stratum. Structural capacities are developed according to AISC 360 and ICC-AC308 considering buckling of 5 ft unbraced length after 75 years of corrosion in moderate to high aggressive soils. Various coatings, custom lengths and helix configurations are available upon request. See Magnum Technical Reference Manual for additional information.

1. Round shafts offer increased lateral and buckling resistance compared to square shafts.
2. Patented alternating helix pattern reduces wobble and improves plumbness and tracking.
3. 45-degree miter pilot point aids pile positioning and advancement.
4. Patented MAGNUM® Dual-Cutting Edge helical bearing plates (DCE) enhance penetration through dense soils with occasional cobbles and debris.
5. Sharpened edge on each helix slices through problem soils.
6. Conforming helix shape limits auguring and provides better quality assurance through valid capacity to torque correlations.

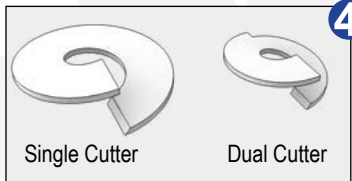
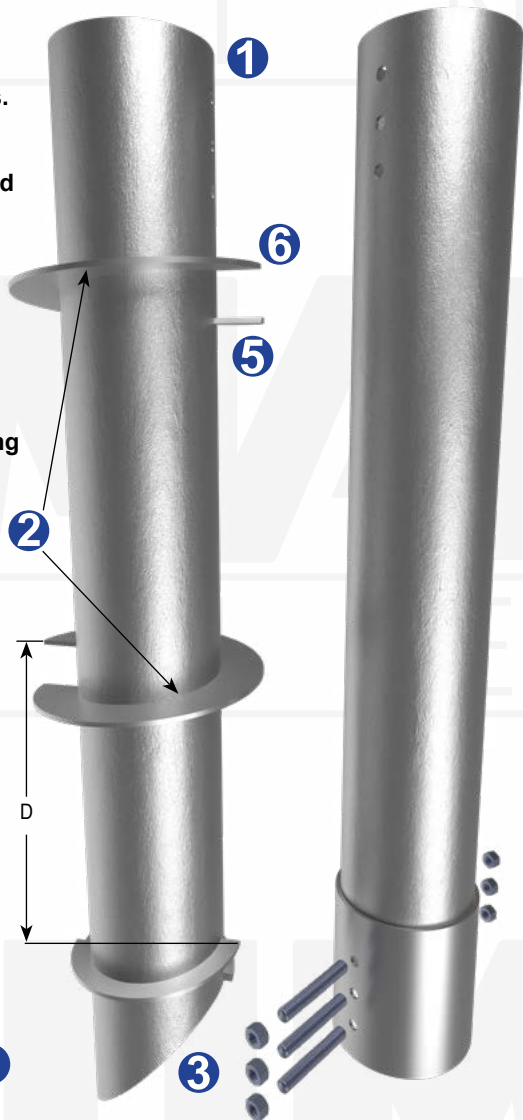

Specifications	
Shaft	18.63" x 0.43" Nominal Pipe ASTM A252, Fy = 50 ksi, or Better
Bolts	(3) 1-1/2" Diameter ASTM A193 B7 Zinc Coated to ASTM B695/F1941
Helices	5/8" Thick, Helix Die-Pressed ASTM A36, or Better 24", 30", 36" & 42" Diameters Available
Spacing 'D'	* 69" TYP
Pitch	6"
Coating	Galvanized (G), Bare Steel (NG), Epoxy Powder Coated (EP)
Properties	
1.9 ft ⁻¹	Ultimate Capacity-to-Torque Ratio
** 281,100 ft-lbs	Maximum Installation Torque
Capacity by Torque	
267 Tons	Ultimate Capacity
134 Tons	Allowable Capacity
Structural Capacity	
*** 267 Tons	Ultimate Capacity
134 Tons	Allowable Capacity

Drawing shows an example pile lead and extension section. Section lengths and number of helices vary with project requirements and soil conditions.

Notes: Helical screw piles shall be installed to appropriate depth into suitable bearing stratum as determined by geotechnical engineer or local practice. Capacity by torque is based on advancing pile to maximum installation torque. A minimum factor of safety of 2.0 is recommended for determining allowable capacity from correlations with final installation torque. Deflections of 0.5" are typical at allowable capacity; a higher factor of safety may be required to achieve smaller deflections. For tension capacity, helical bearing plates must be deeply embedded (5 ~ 7 x ave. helix diameter or as specified by geotechnical engineer). Load tests are recommended when practical.

* Spacing = 87" with 30", 36" & 42" Ø helices.
 ** Maximum Installation Torque rating considers Maximum Driving Stress per ASCE 20.
 *** Structural capacity is shown for galvanized product after 75 years of corrosion. Structural capacity of bare steel product is less due to increased corrosion losses.



156 Circle Freeway Dr.
 Cincinnati, OH 45246
 800-822-7437
www.MagnumPiering.com

MAGNUM® MHT1338-5B Transition Piles

197 Ton Ultimate - 98 Ton Allowable Capacity

High-Strength 13.375" Diameter x 0.38" Top Segment & 5.50" Diameter x 0.47" Round-Shaft with Rigid Couplers

Description: MAGNUM® Helical Transition Piles offer significant increase in lateral capacity and all the advantages of MAGNUM® Helical Piles. MAGNUM® products are manufactured in the USA according to our ISO 9001 approved Quality Program. Our Helical Transition Piles utilize large diameter top segments and rigid bolted couplings to join smaller diameter extensions and the lead section, extending the helical bearing plates down to the desired bearing stratum while providing increased lateral and overturning capacity. Ideal for deep soil formations. Structural capacities are developed according to AISC 360 and ICC-AC358 considering buckling of 5 ft unbraced length after 75 years of corrosion in moderate to high aggressive soils. Various coatings, custom lengths and helix configurations are available upon request. See Magnum Technical Reference Manual for additional information.

1. **Large diameter top segment provides significant increase to lateral and overturning capacities.**
2. **Smaller diameter lead sections provide economical axial capacity.**
3. **Patented alternating helix pattern reduces wobble and improves plumbness and tracking.**
4. **45-degree miter pilot point aids pile positioning and advancement.**
5. **Patented MAGNUM® Dual-Cutting Edge helical bearing plates (DCE) enhance penetration through dense soils with occasional cobbles and debris.**
6. **Sharpened edge on each helix slices through problem soils. Conforming helix shape limits auguring and provides better quality assurance through valid capacity to torque correlations.**

Drawing an example pile lead and extension section. Section lengths and number of helices vary with project requirements and soil conditions.

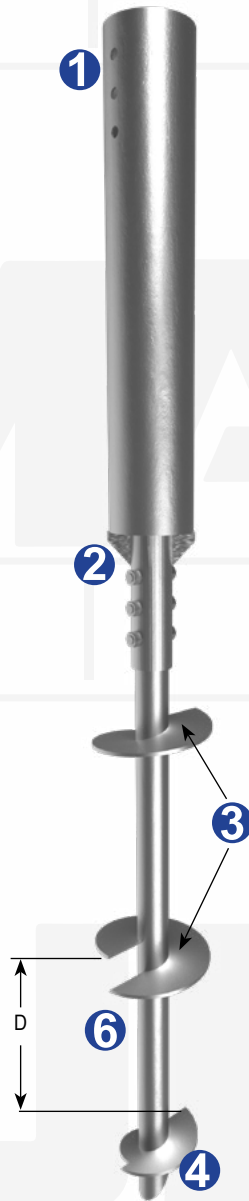
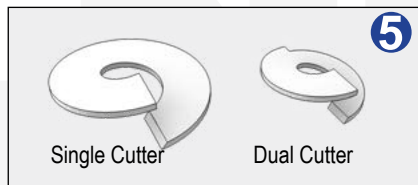

Specifications	
Shaft	13.38" x 0.38" & 5.5" x 0.47" Nominal Pipe ASTM A252, Fy = 50 ksi & Fy = 110 ksi min.,
Bolts	(3) 1-1/2" Diameter SAE J429 Grade 5 Zinc Coated to ASTM B695/F1941
Helices	5/8" Thick, Helix Die-Pressed ASTM A36, or Better 12", 14", 16", 20", 24", 30" & 36" Diameters Available
Spacing 'D'	* 39" TYP
Pitch	6"
Coating	Galvanized (G), Bare Steel (NG), Epoxy Powder Coated (EP)
Properties	
4.8 ft ⁻¹	Ultimate Capacity-to-Torque Ratio
** 82,000 ft-lbs	Maximum Installation Torque
Capacity by Torque	
**** 197 Tons	Ultimate Capacity
98 Tons	Allowable Capacity
Structural Capacity	
*** 234 Tons	Ultimate Capacity
117 Tons	Allowable Capacity

Notes: Helical piles shall be installed to appropriate depth into suitable bearing stratum as determined by geotechnical engineer or local practice. Capacity by torque is based on advancing pile to maximum installation torque. A minimum factor of safety of 2.0 is recommended for determining allowable capacity from correlations with final installation torque. Deflections of 0.5" are typical at allowable capacity; a higher factor of safety may be required to achieve smaller deflections. For tension capacity, helical bearing plates must be deeply embedded (5 ~ 7 x ave. helix diameter or as specified by geotechnical engineer). Load tests are recommended when practical..

* Spacing = 69" with 30" and 36" Ø helices.

** Maximum Installation Torque rating considers Maximum Driving Stress per ASCE 20.

*** Structural capacity is shown for bare steel product after 75 years of corrosion. Structural capacity of galvanized product is more due to decrease in corrosion losses.

**** Capacity shown is for multi-helix configurations. For single helix, limit ultimate capacity to 107 Tons.

U.S. Patents 6,058,662, D612,954, Other Patents Pending

MAGNUM
PIERING
designed to support

156 Circle Freeway Dr.
Cincinnati, OH 45246
800-822-7437
www.MagnumPiering.com

MAGNUM® MHT1649-7B Transition Piles

274 Ton Ultimate - 137 Ton Allowable Capacity

High-Strength 16.0" Diameter x 0.49" Top Segment & 7.0" Diameter x 0.45" Round-Shaft with Rigid Couplers

Description: MAGNUM® Helical Transition Piles offer significant increase in lateral capacity and all the advantages of MAGNUM® Helical Piles. MAGNUM® products are manufactured in the USA according to our ISO 9001 approved Quality Program. Our Helical Transition Piles utilize large diameter top segments and rigid bolted couplings to join smaller diameter extensions and the lead section, extending the helical bearing plates down to the desired bearing stratum while providing increased lateral and overturning capacity. Ideal for deep soil formations. Structural capacities are developed according to AISC 360 and ICC-AC358 considering buckling of 5 ft unbraced length after 75 years of corrosion in moderate to high aggressive soils. Various coatings, custom lengths and helix configurations are available upon request. See Magnum Technical Reference Manual for additional information.

1. **Large diameter top segment provides significant increase to lateral and overturning capacities.**
2. **Smaller diameter lead sections provide economical axial capacity.**
3. **Patented alternating helix pattern reduces wobble and improves plumbness and tracking.**
4. **45-degree miter pilot point aids pile positioning and advancement.**
5. **Patented MAGNUM® Dual-Cutting Edge helical bearing plates (DCE) enhance penetration through dense soils with occasional cobbles and debris.**
6. **Sharpened edge on each helix slices through problem soils. Conforming helix shape limits auguring and provides better quality assurance through valid capacity to torque correlations.**

Drawing shows an example pile lead and extension section. Section lengths and number of helices vary with project requirements and soil conditions.

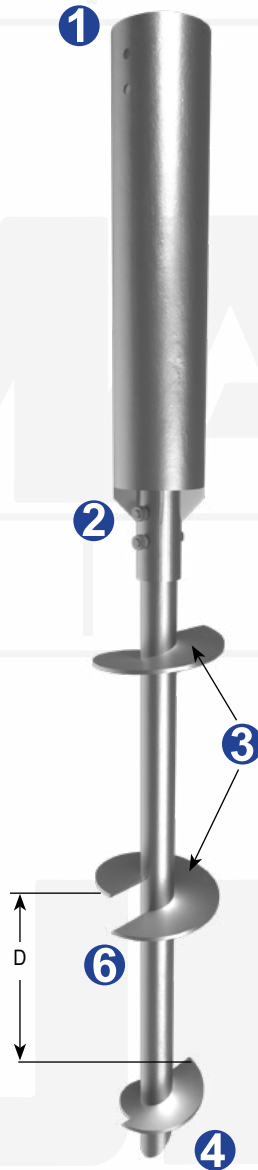
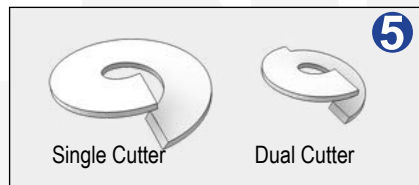

Specifications	
Shaft	16.0" x 0.49" & 7.0" x 0.45" Nominal Pipe ASTM A252, Fy = 50 ksi & Fy = 110 ksi, or Better
Bolts	(3) 1-1/2" Diameter ASTM A193 B7 Zinc Coated to ASTM B695/F1941
Helices	5/8" Thick, Helix Die-Pressed ASTM A36, or Better 14", 16", 20", 24", 30" & 36" Diameters Available
Spacing 'D'	* 69" TYP
Pitch	6"
Coating	Galvanized (G), Bare Steel (NG), Epoxy Powder Coated (EP)
Properties	
3.9 ft ⁻¹	Ultimate Capacity-to-Torque Ratio
** 140,300 ft-lbs	Maximum Installation Torque
Capacity by Torque	
**** 274 Tons	Ultimate Capacity
137 Tons	Allowable Capacity
Structural Capacity	
*** 280 Tons	Ultimate Capacity
140 Tons	Allowable Capacity

Notes: Helical screw piles shall be installed to appropriate depth into suitable bearing stratum as determined by geotechnical engineer or local practice. Capacity by torque is based on advancing pile to maximum installation torque. A minimum factor of safety of 2.0 is recommended for determining allowable capacity from correlations with final installation torque. Deflections of 0.5" are typical at allowable capacity; a higher factor of safety may be required to achieve smaller deflections. For tension capacity, helical bearing plates must be deeply embedded (5 ~ 7 x ave. helix diameter or as specified by geotechnical engineer). Load tests are recommended when practical.

* Spacing = 87" with 30" & 36" Ø helices.
 ** Maximum Installation Torque rating considers Maximum Driving Stress per ASCE 20.
 *** Structural capacity is shown for bare steel product after 75 years of corrosion. Structural capacity of galvanized product is more due to decrease in corrosion losses.
 **** Capacity shown is for multi-helix configurations. For single helix, limit ultimate capacity to 137 Tons.



156 Circle Freeway Dr.
Cincinnati, OH 45246
800-822-7437
www.MagnumPiering.com

MAGNUM® MHT1848-9B Transition Piles

280 Ton Ultimate - 140 Ton Allowable Capacity

High-Strength 18.63" Diameter x 0.48" Top Segment & 9.63" Diameter x 0.39" Round-Shaft with Rigid Couplers

Description: MAGNUM® Helical Transition Piles offer significant increase in lateral capacity and all the advantages of MAGNUM® Helical Piles. MAGNUM® products are manufactured in the USA according to our ISO 9001 approved Quality Program. Our Helical Transition Piles utilize large diameter top segments and rigid bolted couplings to join smaller diameter extensions and the lead section, extending the helical bearing plates down to the desired bearing stratum while providing increased lateral and overturning capacity. Ideal for deep soil formations. Structural capacities are developed according to AISC 360 and ICC-AC358 considering buckling of 5 ft unbraced length after 75 years of corrosion in moderate to high aggressive soils. Various coatings, custom lengths and helix configurations are available upon request. See Magnum Technical Reference Manual for additional information.

- 1. Large diameter top segment provides significant increase to lateral and overturning capacities.**
- 2. Smaller diameter lead sections provide economical axial capacity.**
- 3. Patented alternating helix pattern reduces wobble and improves plumbness and tracking.**
- 4. 45-degree miter pilot point aids pile positioning and advancement.**
- 5. Patented MAGNUM® Dual-Cutting Edge helical bearing plates (DCE) enhance penetration through dense soils with occasional cobbles and debris.**
- 6. Sharpened edge on each helix slices through problem soils. Conforming helix shape limits auguring and provides better quality assurance through valid capacity to torque correlations.**

Drawing shows an example pile lead and extension section. Section lengths and number of helices vary with project requirements and soil conditions.

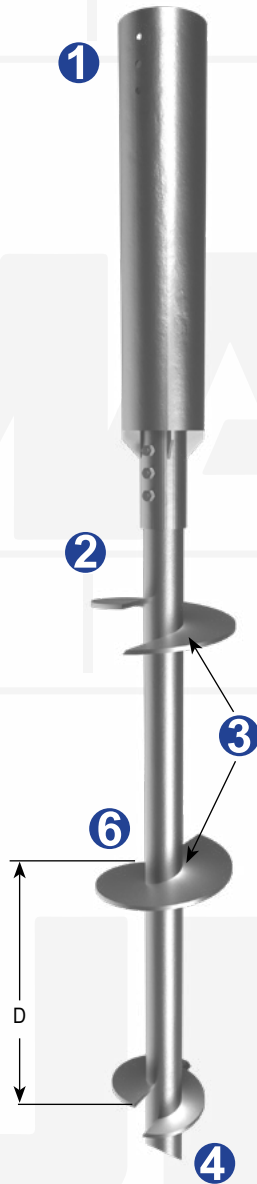
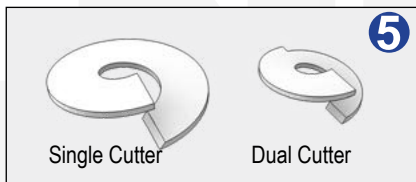

Specifications	
Shaft	18.63" x 0.48" & 9.63" x 0.39" Nominal Pipe ASTM A252, Fy = 50 ksi & Fy = 80 ksi, or Better
Bolts	(3) 1-1/2" Diameter ASTM A193 B7 Zinc Coated to ASTM B695/F1941
Helices	5/8" Thick, Helix Die-Pressed ASTM A36, or Better 16", 20", 24", 30", 36" & 42" Diameters Available
Spacing 'D'	* 69" TYP
Pitch	6"
Coating	Galvanized (G), Bare Steel (NG), Epoxy Powder Coated (EP)
Properties	
3.0 ft ⁻¹	Ultimate Capacity-to-Torque Ratio
** 186,700 ft-lbs	Maximum Installation Torque
Capacity by Torque	
**** 280 Tons	Ultimate Capacity
140 Tons	Allowable Capacity
Structural Capacity	
*** 280 Tons	Ultimate Capacity
140 Tons	Allowable Capacity

Notes: Helical screw piles shall be installed to appropriate depth into suitable bearing stratum as determined by geotechnical engineer or local practice. Capacity by torque is based on advancing pile to maximum installation torque. A minimum factor of safety of 2.0 is recommended for determining allowable capacity from correlations with final installation torque. Deflections of 0.5" are typical at allowable capacity; a higher factor of safety may be required to achieve smaller deflections. For tension capacity, helical bearing plates must be deeply embedded (5 ~ 7 x ave. helix diameter or as specified by geotechnical engineer). Load tests are recommended when practical..

* Spacing = 87" with 30", 36" & 42" Ø helices.
 ** Maximum Installation Torque rating considers Maximum Driving Stress per ASCE 20.
 *** Structural capacity is shown for bare steel product after 75 years of corrosion. Structural capacity of galvanized product is more due to decrease in corrosion losses.
 **** Capacity shown is for multi-helix configurations. For single helix, limit ultimate capacity to 188 Tons.



156 Circle Freeway Dr.
Cincinnati, OH 45246
800-822-7437
www.MagnumPiering.com

MAGNUM® Helical Pile Sizing Guide (tons)

MS150B, MS175B, MH2325U, MH222U, MH227U(-6), MH313B,
 MH3131BR, MH325B, MH325BR(-6) Series Helical Piles in Cohesive Soils

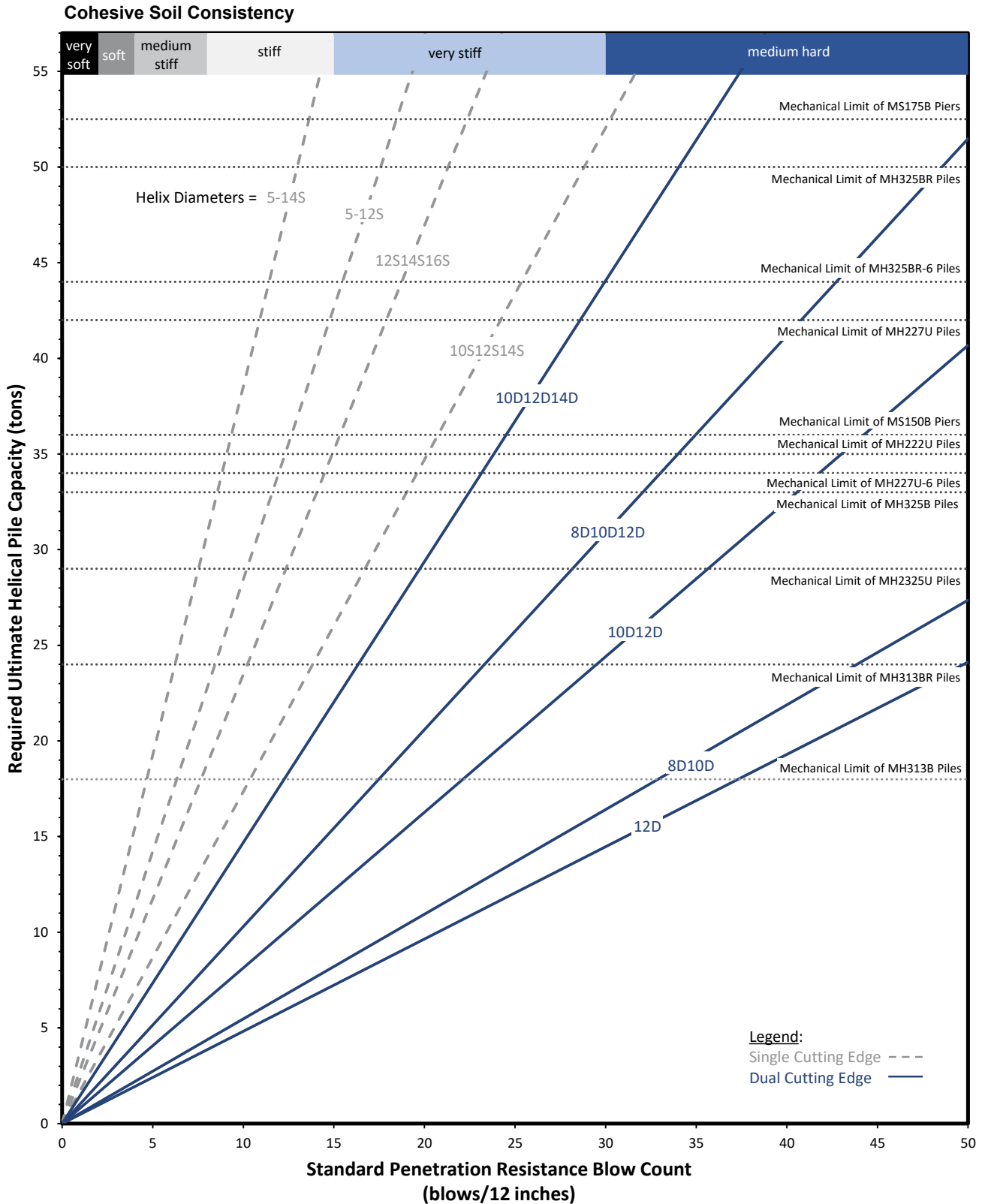

Limitations: Helical pile sizing charts represent an estimate of the theoretical ultimate capacity of helical piles in ground. Installation torque and load tests, where applicable, should be used to verify capacity. Helical pile performance is a function of installation, which Magnum cannot control, and ground conditions, which can vary with location and depth; as such, no warranty is made, express or implied, regarding foundation product capacity in ground. Magnum recommends bidders include provisions for additional pile length and/or obstructions in their bid documents

MAGNUM® Helical Pile Sizing Guide (tons)

MS150B, MS175B, MH2325U, MH222U, MH227U(-6), MH313B, MH313BR, MH325B, MH325BR(-6) Series Helical Piles in Non-Cohesive Soils

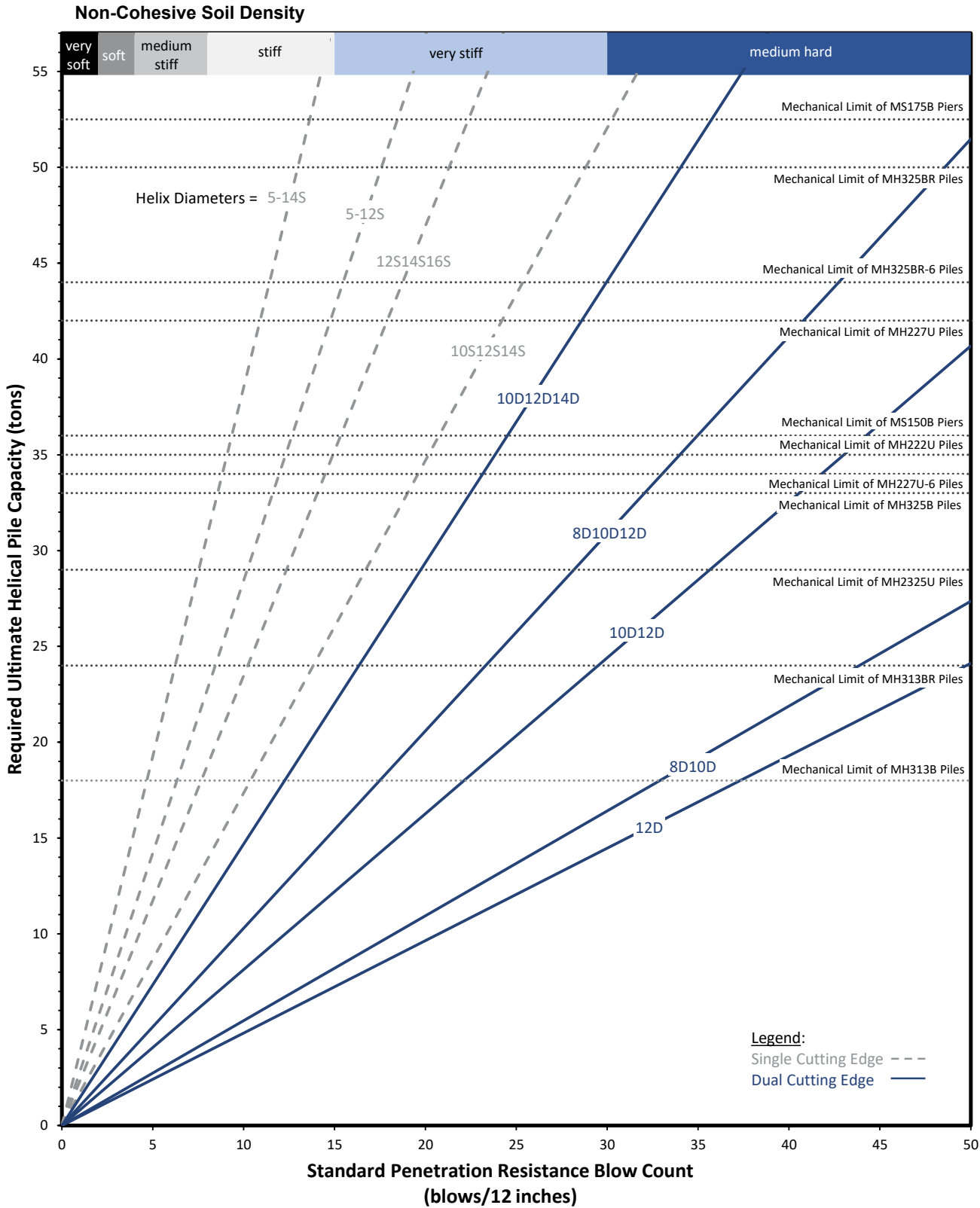

Limitations: Helical pile sizing charts represent an estimate of the theoretical ultimate capacity of helical piles in ground. Installation torque and load tests, where applicable, should be used to verify capacity. Helical pile performance is a function of installation, which Magnum cannot control, and ground conditions, which can vary with location and depth; as such, no warranty is made, express or implied, regarding foundation product capacity in ground. Magnum recommends bidders include provisions for additional pile length and/or obstructions in their bid documents

MAGNUM® Helical Pile Sizing Guide (tons)

MS150B, MS175B, MH2325U, MH222U, MH227U(-6), MH313B, MH313BR, MH325B, MH325BR(-6) Series Helical Piles in Sedimentary Rock

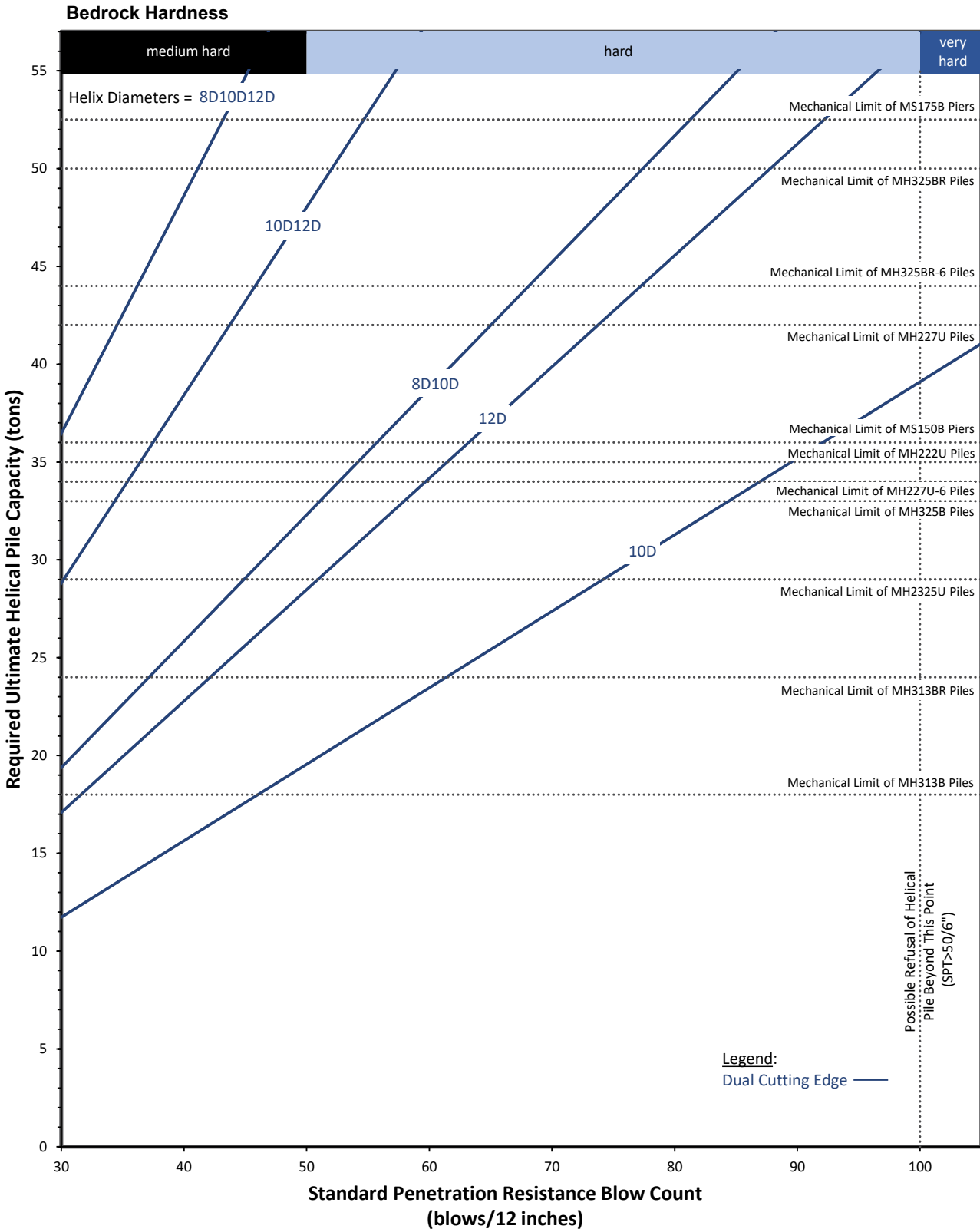

Limitations: Helical pile sizing charts represent an estimate of the theoretical ultimate capacity of helical piles in ground. Installation torque and load tests, where applicable, should be used to verify capacity. Helical pile performance is a function of installation, which Magnum cannot control, and ground conditions, which can vary with location and depth; as such, no warranty is made, express or implied, regarding foundation product capacity in ground. Magnum recommends bidders include provisions for additional pile length and/or obstructions in their bid documents

MAGNUM® Helical Pile Sizing Guide (tons)

MH3521U, MH3530U, MH429U, MH429Y, MH434U(-6)

Series Helical Piles in Cohesive Soils

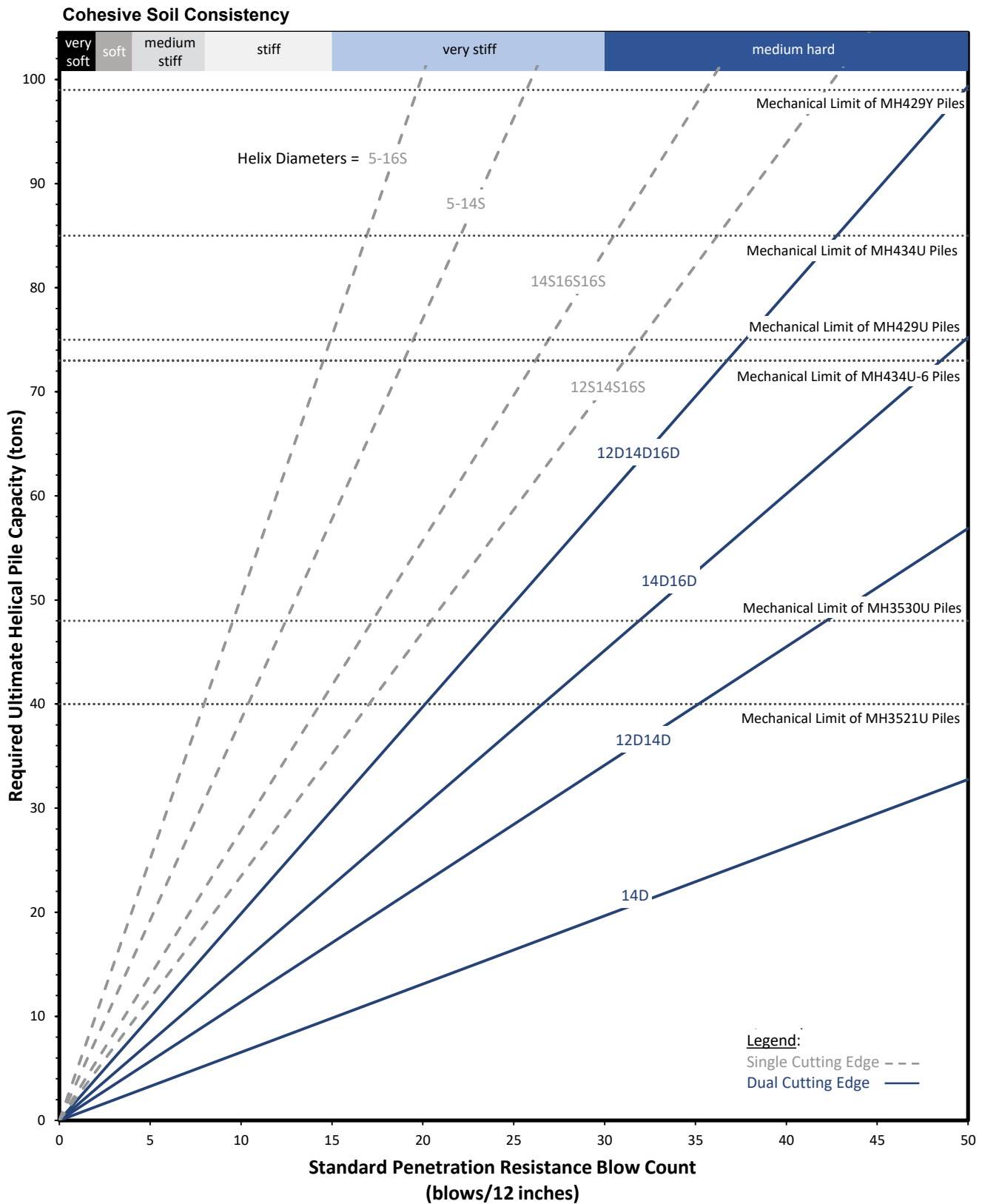

Limitations: Helical pile sizing charts represent an estimate of the theoretical ultimate capacity of helical piles in ground. Installation torque and load tests, where applicable, should be used to verify capacity. Helical pile performance is a function of installation, which Magnum cannot control, and ground conditions, which can vary with location and depth; as such, no warranty is made, express or implied, regarding foundation product capacity in ground. Magnum recommends bidders include provisions for additional pile length and/or obstructions in their bid documents

MAGNUM® Helical Pile Sizing Guide (tons)

MH3521U, MH3530U, MH429U, MH429Y, MH434U(-6)

Series Helical Piles in Non-Cohesive Soils

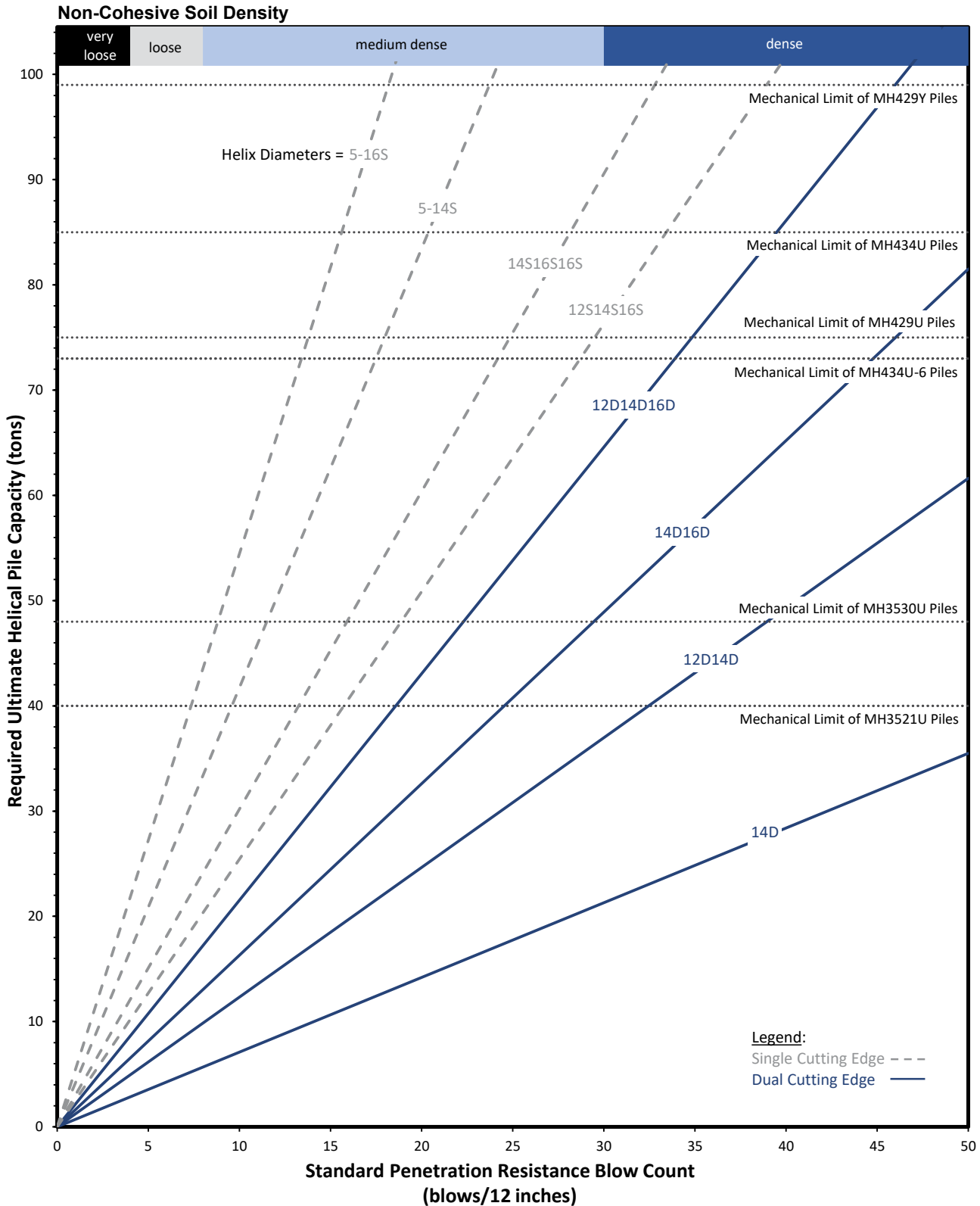

Limitations: Helical pile sizing charts represent an estimate of the theoretical ultimate capacity of helical piles in ground. Installation torque and load tests, where applicable, should be used to verify capacity. Helical pile performance is a function of installation, which Magnum cannot control, and ground conditions, which can vary with location and depth; as such, no warranty is made, express or implied, regarding foundation product capacity in ground. Magnum recommends bidders include provisions for additional pile length and/or obstructions in their bid documents

MAGNUM® Helical Pile Sizing Guide (tons)

MH3521U, MH3530U, MH429U, MH429Y, MH434U(-6)

Series Helical Piles in Sedimentary Rock

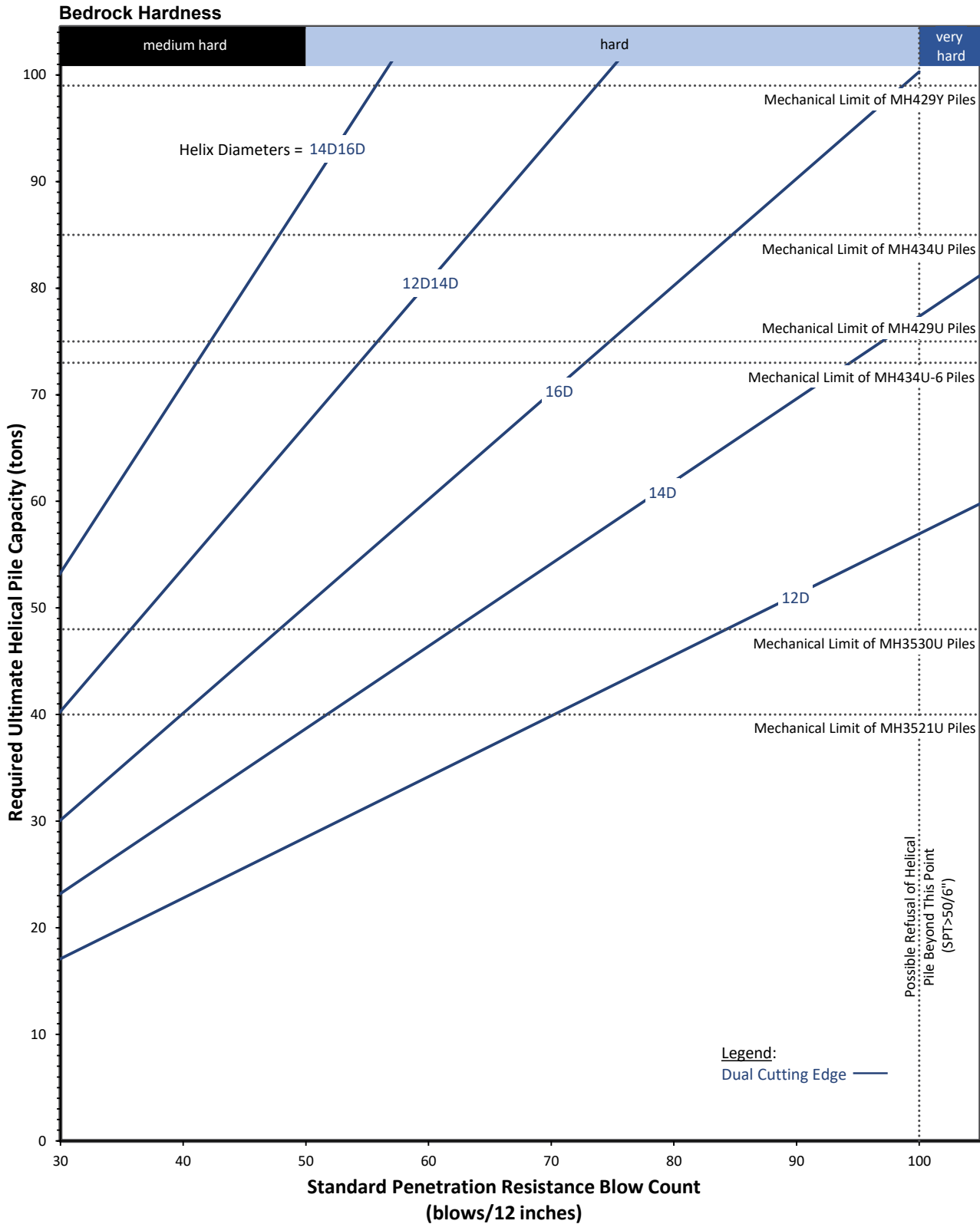

Limitations: Helical pile sizing charts represent an estimate of the theoretical ultimate capacity of helical piles in ground. Installation torque and load tests, where applicable, should be used to verify capacity. Helical pile performance is a function of installation, which Magnum cannot control, and ground conditions, which can vary with location and depth; as such, no warranty is made, express or implied, regarding foundation product capacity in ground. Magnum recommends bidders include provisions for additional pile length and/or obstructions in their bid documents

MAGNUM® Helical Pile Sizing Guide (tons)

MH530Y-6, MH536Y-6, MH542Y-6, MH547Y-6, MH736U-6, MH740U-6, MH745U-6, MH850Q-6 Helical Piles in Cohesive Soils

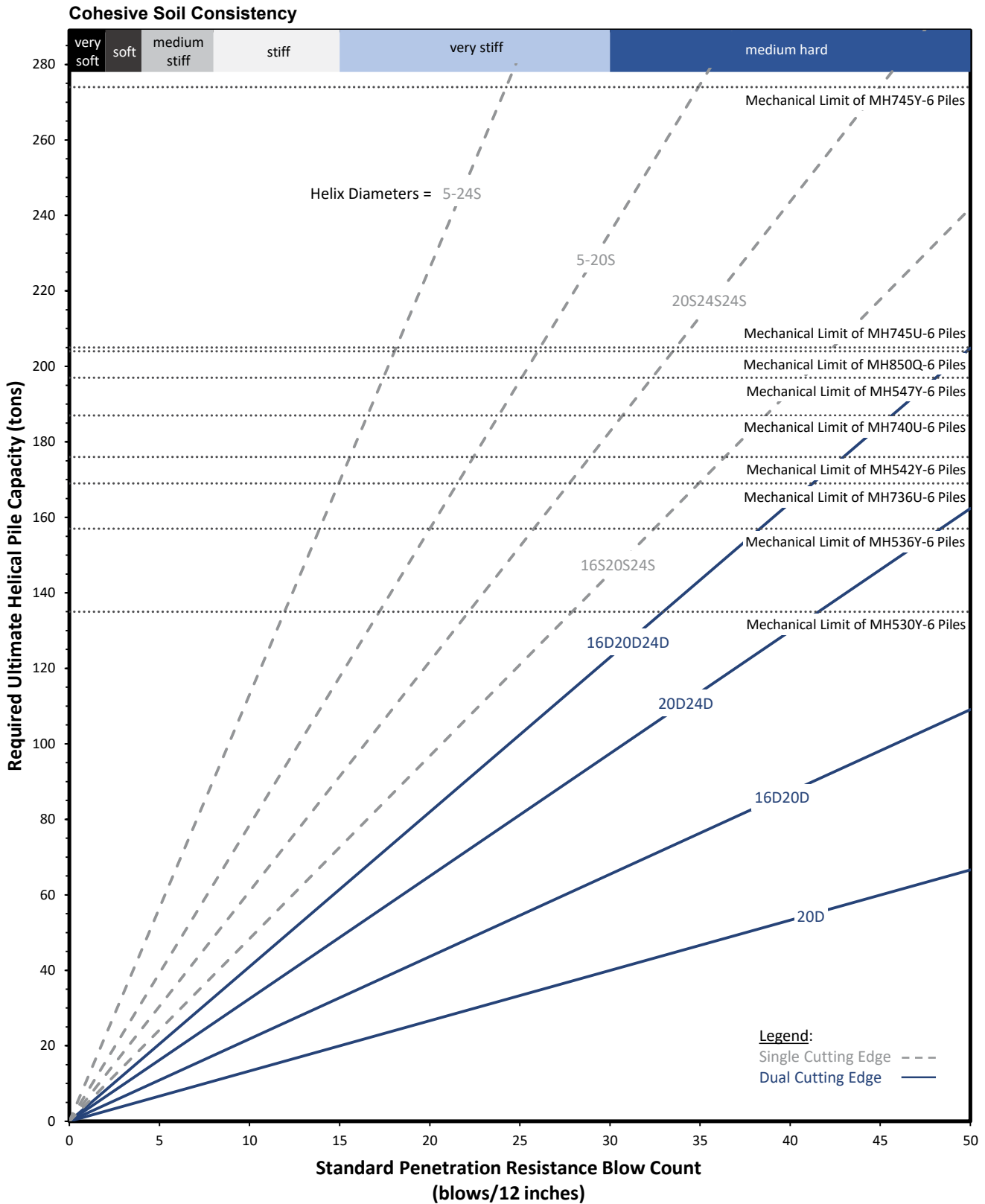

Limitations: Helical pile sizing charts represent an estimate of the theoretical ultimate capacity of helical piles in ground. Installation torque and load tests, where applicable, should be used to verify capacity. Helical pile performance is a function of installation, which Magnum cannot control, and ground conditions, which can vary with location and depth; as such, no warranty is made, express or implied, regarding foundation product capacity in ground. Magnum recommends bidders include provisions for additional pile length and/or obstructions in their bid documents

MAGNUM® Helical Pile Sizing Guide (tons)

MH530Y-6, MH536Y-6, MH542Y-6, MH547Y-6, MH736U-6, MH740U-6, MH745U-6, MH850Q-6 Helical Piles in Non-Cohesive Soils

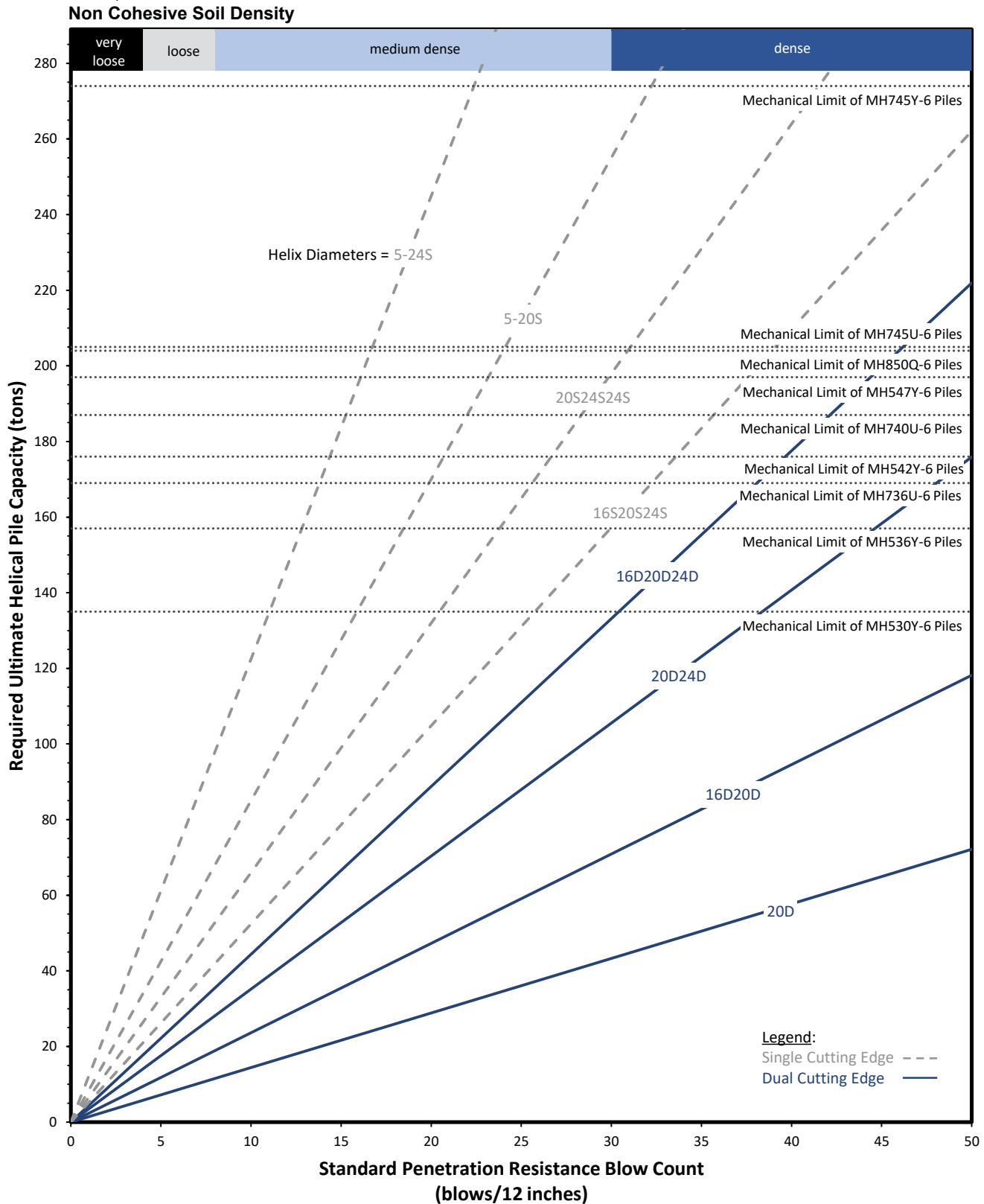

Limitations: Helical pile sizing charts represent an estimate of the theoretical ultimate capacity of helical piles in ground. Installation torque and load tests, where applicable, should be used to verify capacity. Helical pile performance is a function of installation, which Magnum cannot control, and ground conditions, which can vary with location and depth; as such, no warranty is made, express or implied, regarding foundation product capacity in ground. Magnum recommends bidders include provisions for additional pile length and/or obstructions in their bid documents

MAGNUM® Helical Pile Sizing Guide (tons)

MH530Y-6, MH536Y-6, MH542Y-6, MH547Y-6, MH736U-6, MH740U-6, MH745U-6, MH850Q-6 Helical Piles in Sedimentary Rock

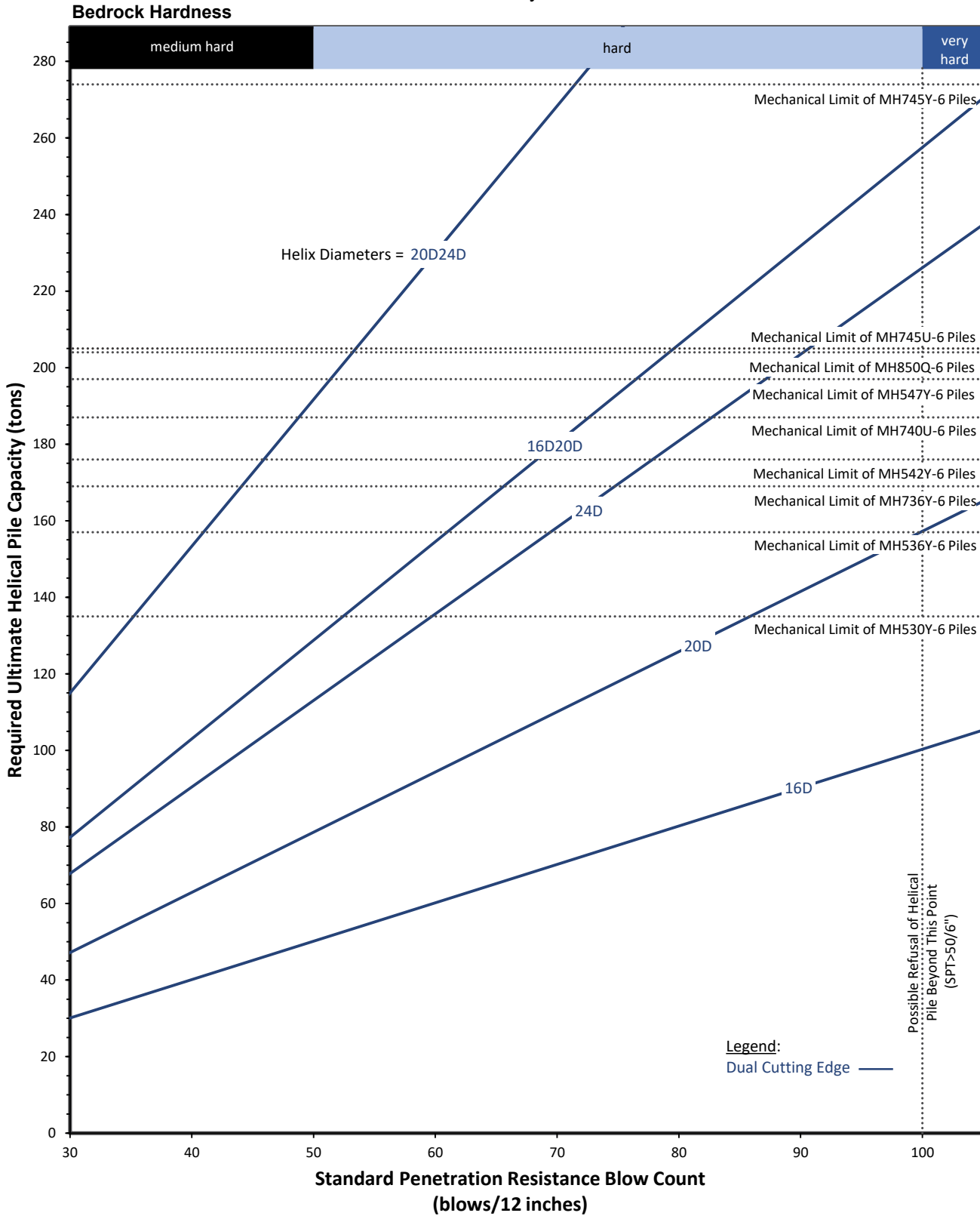

Limitations: Helical pile sizing charts represent an estimate of the theoretical ultimate capacity of helical piles in ground. Installation torque and load tests, where applicable, should be used to verify capacity. Helical pile performance is a function of installation, which Magnum cannot control, and ground conditions, which can vary with location and depth; as such, no warranty is made, express or implied, regarding foundation product capacity in ground. Magnum recommends bidders include provisions for additional pile length and/or obstructions in their bid documents

MAGNUM® Helical Pile Sizing Guide (tons)

MH939U-6, MH1050U-6, MH1250Q6-6, MH1843Q-6

Helical Piles in Cohesive Soils

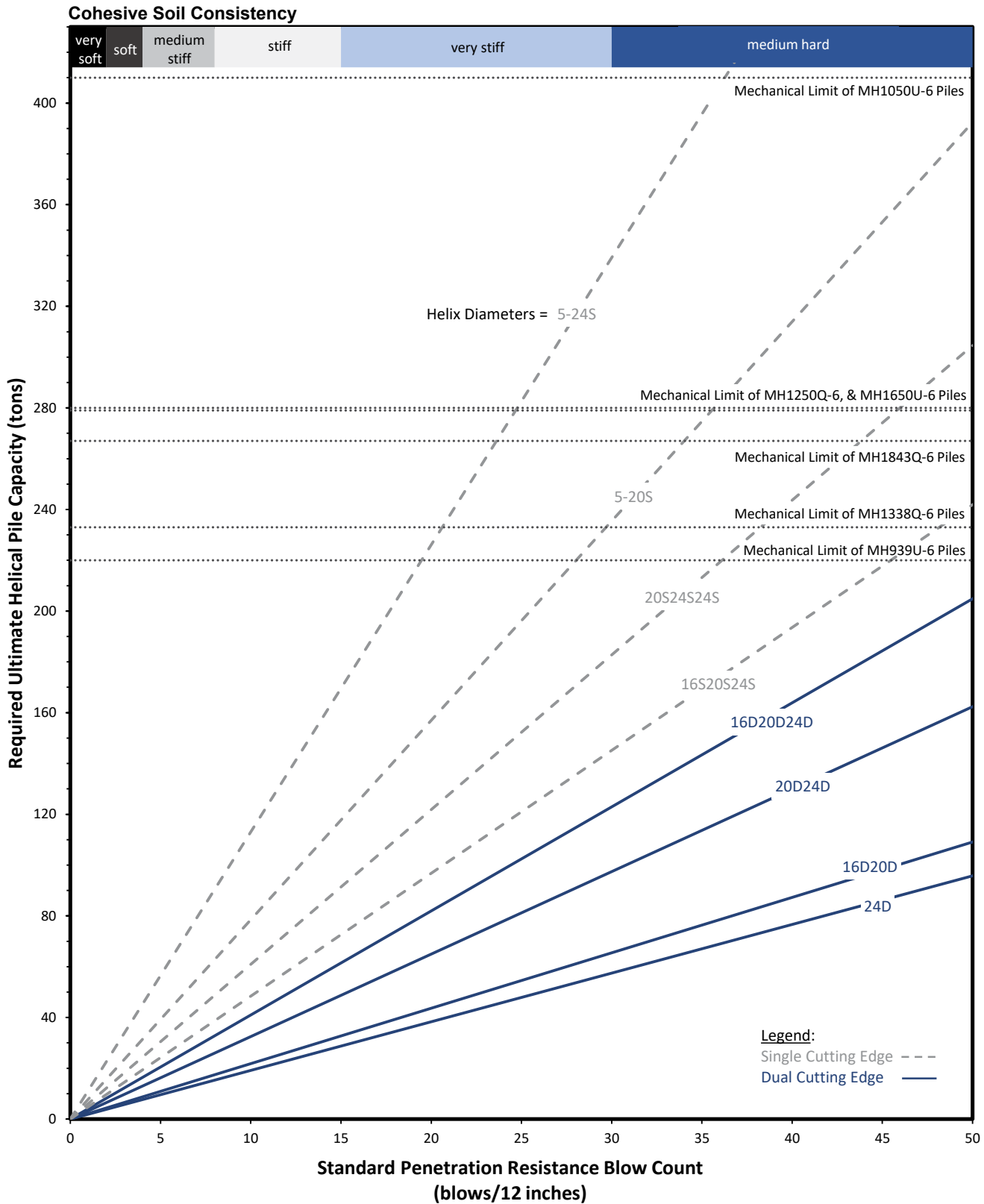

Limitations: Helical pile sizing charts represent an estimate of the theoretical ultimate capacity of helical piles in ground. Installation torque and load tests, where applicable, should be used to verify capacity. Helical pile performance is a function of installation, which Magnum cannot control, and ground conditions, which can vary with location and depth; as such, no warranty is made, express or implied, regarding foundation product capacity in ground. Magnum recommends bidders include provisions for additional pile length and/or obstructions in their bid documents

MAGNUM® Helical Pile Sizing Guide (tons)

MH939U-6, MH1050U-6, MH1250Q-6, MH1338Q, 1650Q-6 & MH1843Q-6

Helical Piles in Non-Cohesive Soils

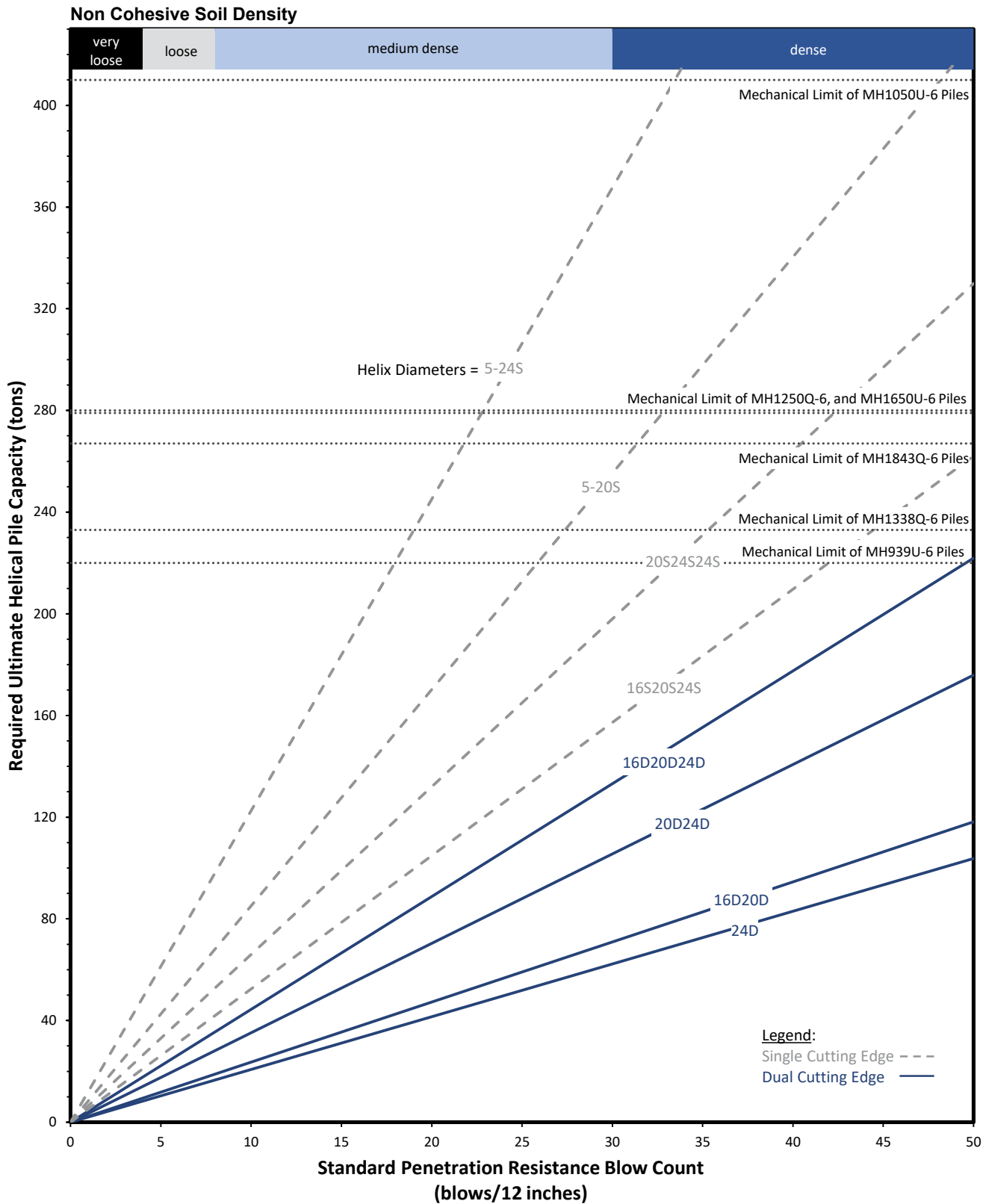

Limitations: Helical pile sizing charts represent an estimate of the theoretical ultimate capacity of helical piles in ground. Installation torque and load tests, where applicable, should be used to verify capacity. Helical pile performance is a function of installation, which Magnum cannot control, and ground conditions, which can vary with location and depth; as such, no warranty is made, express or implied, regarding foundation product capacity in ground. Magnum recommends bidders include provisions for additional pile length and/or obstructions in their bid documents

MAGNUM® Helical Pile Sizing Guide (tons)

MH939U-6, MH1050U-6, MH1250Q-6, MH1338Q-6, 1650Q-6, MH1843Q-6

Helical Piles in Sedimentary Rock

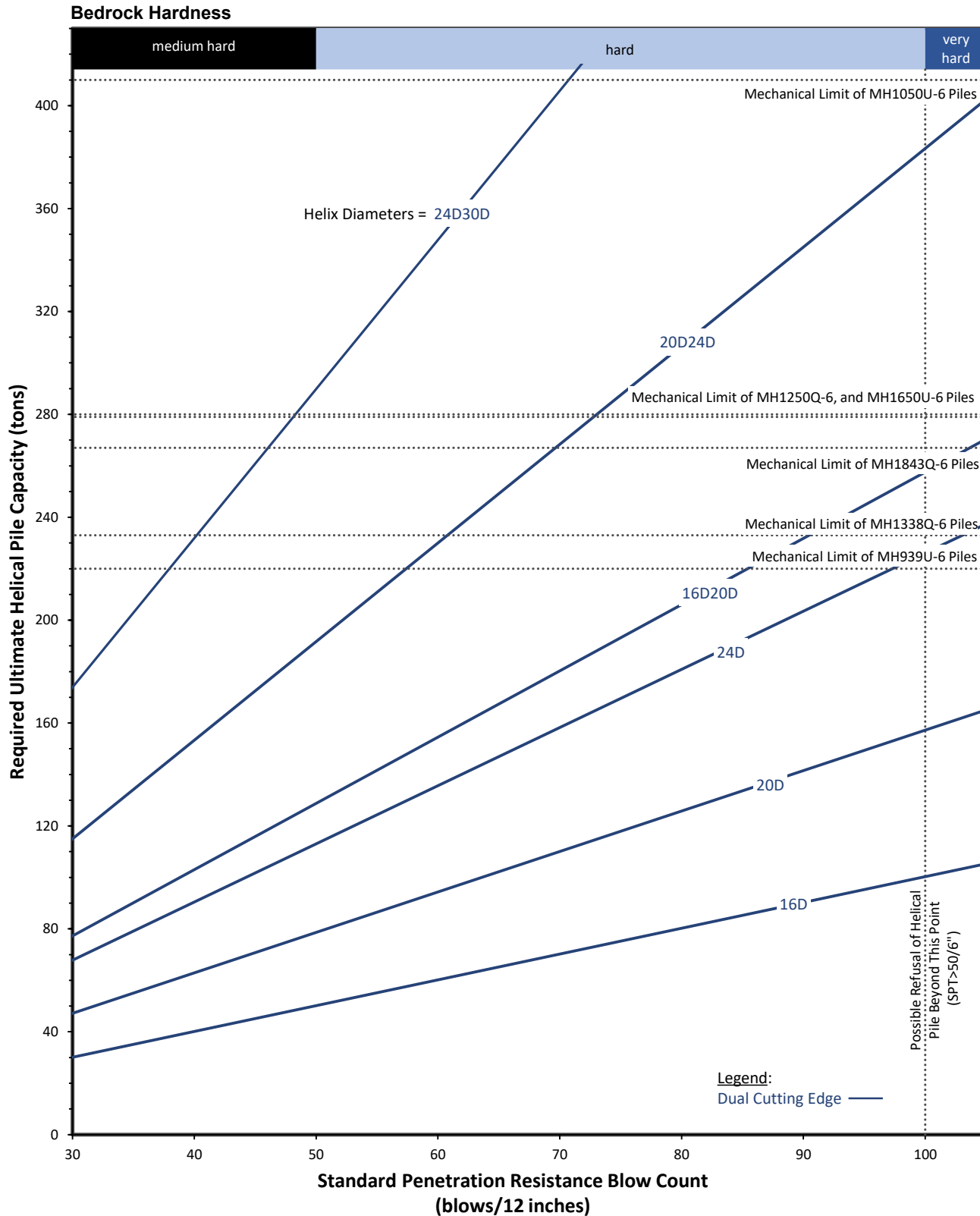

Limitations: Helical pile sizing charts represent an estimate of the theoretical ultimate capacity of helical piles in ground. Installation torque and load tests, where applicable, should be used to verify capacity. Helical pile performance is a function of installation, which Magnum cannot control, and ground conditions, which can vary with location and depth; as such, no warranty is made, express or implied, regarding foundation product capacity in ground. Magnum recommends bidders include provisions for additional pile length and/or obstructions in their bid documents

MAGNUM® Helical Shaft Buckling Capacity* vs. Effective Unbraced Length**



Per IBC 2021, any pile standing unbraced in air, water, or fluid soils shall be designed as a column. Helical piles generate a small annular space around the top of the pile during installation. To be conservative, Magnum typically recommends helical piles be checked for buckling.

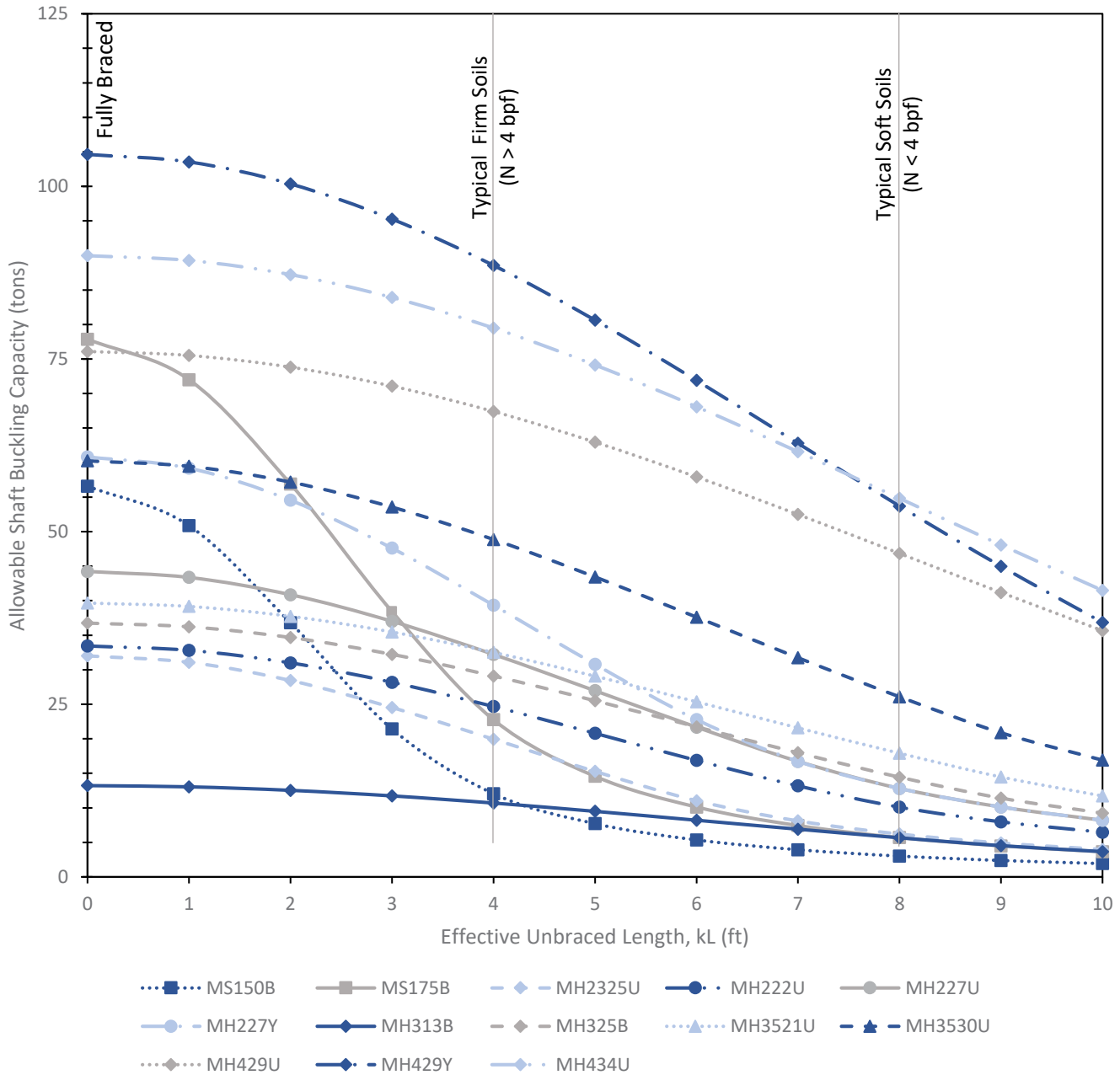

* Buckling Capacity refers to structural capacity of steel only, per AISC 360-16 Chapter E. Pile capacity may be governed by geotechnical capacity.

** Effective unbraced length should be calculated using effective length factor, k, per AISC 360 multiplied by the actual unbraced length (unbraced length in soil should be accounted for per IBC 2021, see below). Typically, k = 0.65 is used for fixed head, k = 0.8 is used for pinned head, and k = 2.1 is used for free head conditions.

*** If fluid soils occur at some depth below ground surface, some codes suggest piles be considered pinned at 4 pile diameters and the greater unbraced length should be used for capacity. Firm and soft soil lines shown on graph accounts for effective length coefficient of 0.8 for pinned head condition.

*Limitations: These capacity tables are based on axial compressive load applied concentrically to the pile shaft with no eccentricity and bare shafts with 75 years corrosion in non-severe corrosive conditions. Contact MAGNUM® technical support professionals for axial capacity when loads are applied eccentric to the pile shaft or for other corrosion conditions.

MAGNUM® Helical Shaft Buckling Capacity* vs. Effective Unbraced Length**



Per IBC 2021, any pile standing unbraced in air, water, or fluid soils shall be designed as a column. Helical piles generate a small annular space around the top of the pile during installation. To be conservative, Magnum typically recommends helical piles be checked for buckling.

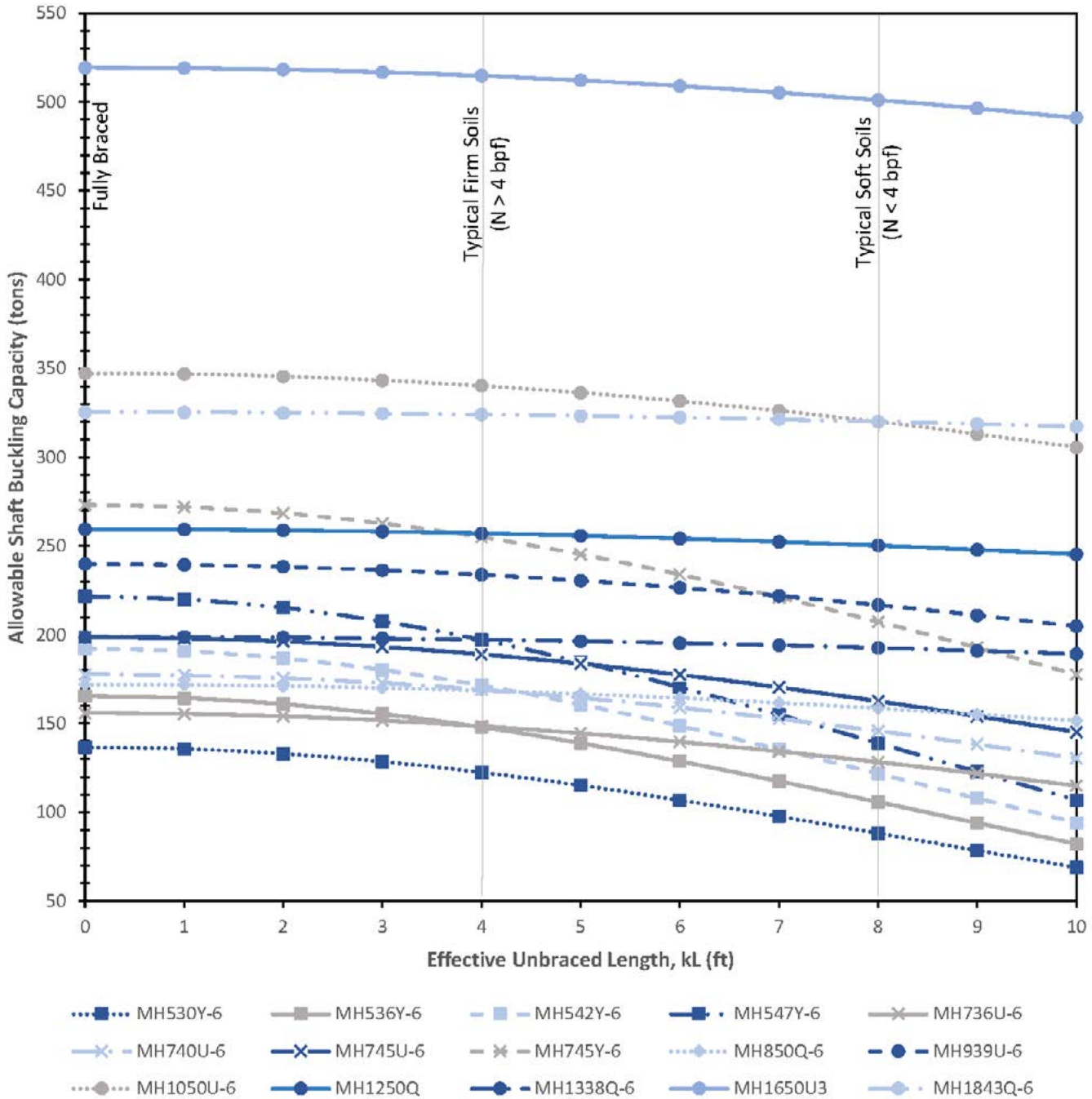

* Buckling Capacity refers to structural capacity of steel only, per AISC 360-18 Chapter E. Pile capacity may be governed by geotechnical capacity.

** Effective unbraced length should be calculated using effective length factor, k, per AISC 360 multiplied by the actual unbraced length (unbraced length in soil should be accounted for per IBC 2021, see below). Typically, k = 0.65 is used for fixed head, k = 0.8 is used for pinned head, and k = 2.1 is used for free head conditions.

*** If fluid soils occur at some depth below ground surface, some codes suggest piles be considered pinned at 4 pile diameters and the greater unbraced length should be used for capacity. Firm and soft soil lines shown on graph accounts for effective length coefficient of 0.8 for pinned head condition.

*Limitations: These capacity tables are based on axial compressive load applied concentrically to the pile shaft with no eccentricity and bare shafts with 75 years corrosion in non-severe corrosive conditions. Contact MAGNUM® technical support professionals for axial capacity when loads are applied eccentric to the pile shaft or for other corrosion conditions.

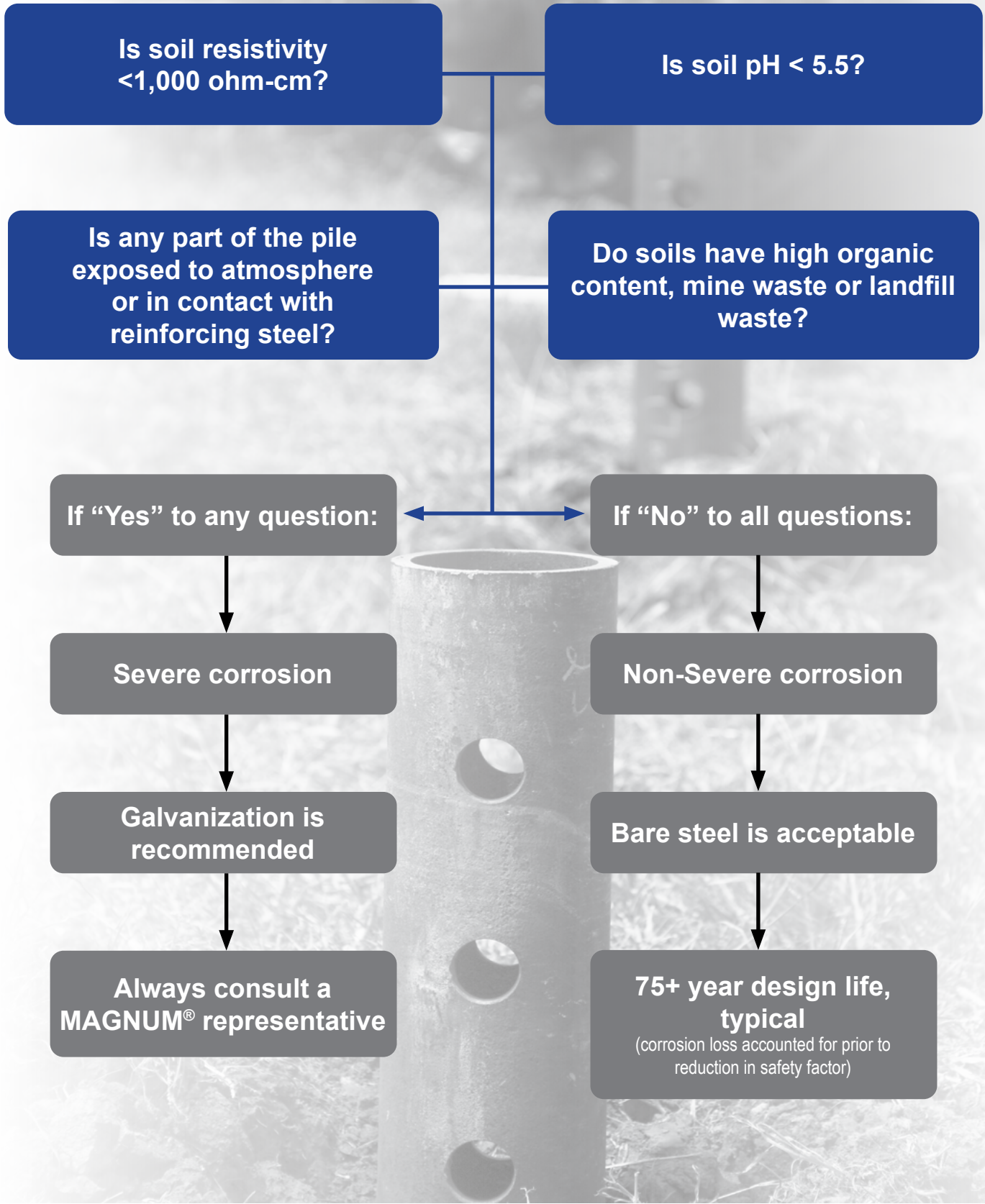

Foundation Products Corrosion and Life Expectancy

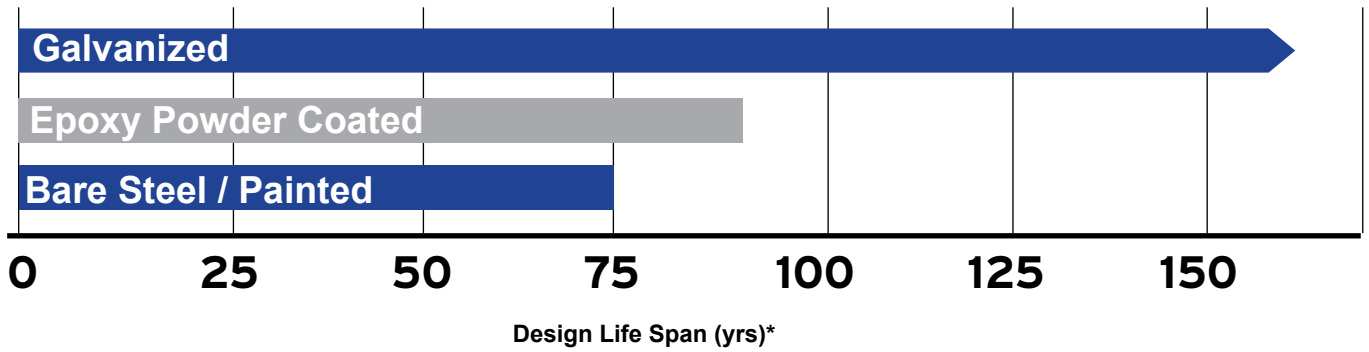

Structural capacities and section properties shown in this catalog are based on a design lifespan of 75 years in most soil conditions for bare steel or painted surfaces unless noted otherwise. Design lifespan can be extended 16 years by epoxy powder coating or more than doubled by hot-dip zinc galvanizing to ASTM A123/A153.

*Design lifespan is determined by back calculating the time required for a corrosion loss thickness of 50 mils using the rates of corrosion per ICC-ES Document AC358 Guidelines for Design of Helical Foundation Systems and Devices for moderate to highly corrosive soil conditions. Design lifespan is considerably shorter in conditions indicative of severe pile corrosion. Severe pile corrosion conditions are defined by soil resistivity less than 1,000 ohm-cm, soil pH less than 5.5, soils with high organic content, soils located in landfills, or soil containing mine waste. Design life also may be shortened for piles, anchors, caps and brackets exposed to atmosphere or in direct electrical contact with reinforcing steel or structural steel.

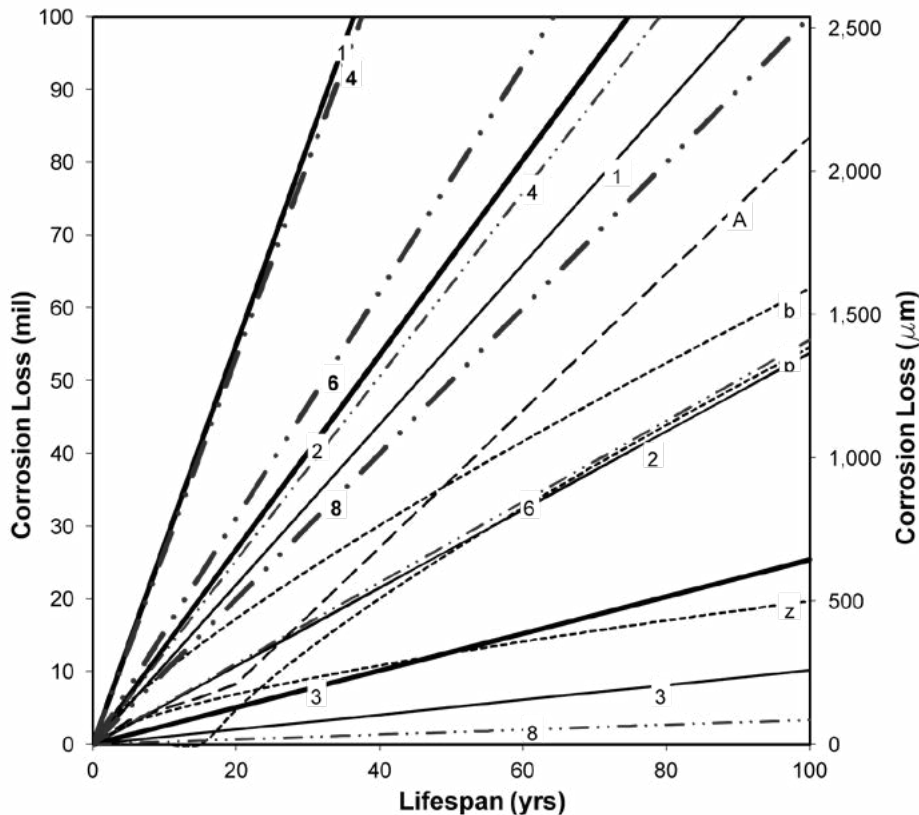

Alternative methods of corrosion loss calculation are available for varying soil conditions and with different building code authorities as shown in the table to the left from Perko (2009) Helical Piles: A Practical Guide to Design and Installation. Florida DOT and Canadian Building Codes provide other useful references.

MAGNUM® technical support personnel can provide assistance with regard to alternative corrosion loss calculation methods. MAGNUM® corrosion engineers should be consulted for severe corrosion conditions, for products exposed to atmosphere, and when product applications require direct contact with reinforcing bars or structural steel.

Perko (2004a), Bare Steel	—1— Severe	—2— Mod-High	—3— Low
Perko (2004a), Galvanized Steel	—1— Severe	—2— Mod-High	—3— Low
ICC-ES(2007)	---z--- Zinc	---b--- Bare	---p--- Powder
AASHTO (2004)	---A--- Zinc+Brae		
King (1977), 4,00 ohm-cm	—4-- pH4	—6-- pH6	—8-- pH8
	—4-- pH4	—6-- pH6	—8-- pH8

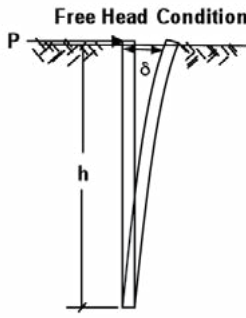

MAGNUM® Helical Pile Allowable Lateral Shaft Capacity (lbs)*

Head Fixity	Helical Pile	Non-Cohesive Soils				Cohesive Soils			
		V. Loose	Loose	Medium	Dense	V. Soft	Soft	Medium	Stiff
 <p>Free Head Condition</p> <p>Pile Head Free To Rotate</p>	MH2325U	300	600	900	1,300	300	700	1,200	2,200
	MH222U	400	800	1,200	1,600	400	900	1,500	2,700
	MH227U	500	900	1,300	1,800	400	900	1,600	2,800
	MH313B/BR	400	700	1,000	1,400	400	800	1,400	2,400
	MH325B/BR	500	1,000	1,300	1,800	500	900	1,700	2,900
	MH3521U	600	1,200	1,600	2,200	500	1,100	2,000	3,400
	MH3530U	700	1,300	1,800	2,500	500	1,200	2,100	3,700
	MH429U/Y	1,000	1,900	2,700	3,700	800	1,600	2,900	5,100
	MH434U	1,100	2,100	2,900	3,900	800	1,700	3,000	5,300
	MH530Y	1,500	2,700	3,700	5,100	1,000	2,100	3,800	6,800
	MH536Y	1,600	2,900	4,000	5,500	1,100	2,200	4,000	7,100
	MH542Y	1,600	3,000	4,200	5,700	1,100	2,300	4,200	7,300
	MH547Y	1,700	3,100	4,400	6,000	1,100	2,400	4,300	7,500
	MH736U	2,200	4,100	5,700	7,800	1,500	3,100	5,500	9,600
	MH740U	2,300	4,300	6,000	8,300	1,600	3,200	5,700	9,800
	MH745U/Y	2,400	4,500	6,300	8,600	1,600	3,200	5,800	10,100
	MH850Q	3,300	6,300	8,800	12,100	2,400	4,300	7,900	13,700
	MH939U	3,500	6,800	9,500	13,100	2,300	4,600	8,500	14,800
	MH1050U	4,400	8,800	12,300	16,800	2,900	5,700	10,500	18,000
	MH1250Q	5,500	11,300	15,800	21,900	3,600	7,100	12,900	22,600
MH1338Q	5,300	11,000	15,300	21,300	3,600	7,000	12,800	22,300	
MH1650U	7,300	15,900	22,300	31,100	4,800	9,400	17,300	30,000	
MH1843Q	8,300	19,000	27,000	37,500	5,700	11,000	20,300	35,000	
Minimum Pile Depth, h =		28d	28d	28d	28d	34d	34d	34d	34d

Index Soil Properties:	Non-Cohesive Soils				Cohesive Soils			
	V. Loose	Loose	Medium	Dense	V. Soft	Soft	Medium	Stiff
SPT Blow Count (bpf)	1-4	4-10	10-30	30-50	1-2	2-4	4-8	8-15
Strain, ϵ_{50}	N/A	N/A	N/A	N/A	0.06	0.02	0.01	0.005
p-y Modulus (pci)	5	25	90	225	30	100	500	1000
Cohesion (psf)	0	0	0	0	200	400	800	1500
Friction Angle (deg)	25	29	33	39	0	0	0	0
Unit Weight (pcf)	70	90	110	120	80	85	90	100

PILE HEAD FIXITY EXAMPLES

NOTE: MINIMUM EMBEDMENT REQUIREMENTS APPLY.

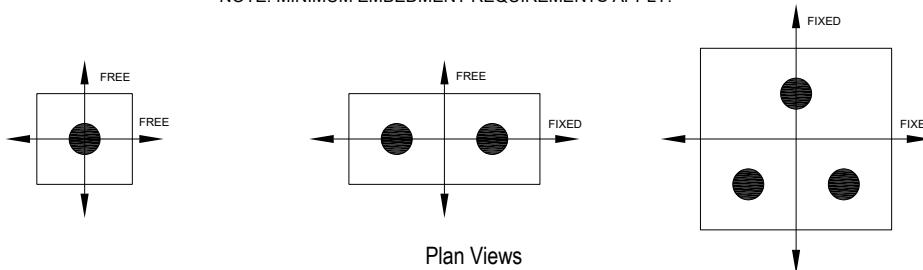

1 Allowable lateral capacity for round-shaft helical piles. Square shaft helical piles (MS150B and MS175B) have negligible lateral capacity
 *Limitations: IBC2021 states that the allowable lateral capacity of a pile shall be half the load causing 1-inch of deflection. Many professionals use the lateral capacity at a deflection of 0.5 inches as the allowable lateral capacity. The allowable lateral capacities shown in these tables are based on a predicted deflection of 0.5 inches at the ground surface. Refer to MAGNUM® Technical Reference Manual for theoretical load displacement curves and for allowable capacities at other deflection limits. These capacity tables are based on lateral load applied at ground surface and galvanized shafts with 50 years corrosion in non-severe corrosive conditions. Contact MAGNUM® technical support professionals for lateral capacity when loads are applied above ground, for other corrosion conditions, or for resistance to bending moments. Occasionally, annular space can develop around upper portions of the shaft when helical piles have multiple bolted couplings (all MAGNUM® helical piles larger than 3.5" diameter) or when installation methods cause excessive wobbling. It is recommended that any annular space be grouted from the surface using fast-setting, non-shrink, neat cement grout when lateral capacity is required.

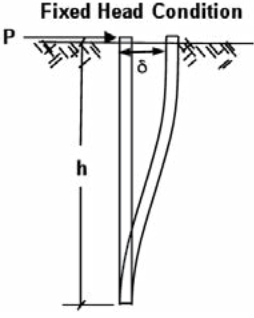

MAGNUM® Helical Pile Allowable Lateral Shaft Capacity (lbs)*

Head Fixity	Helical Pile	Non-Cohesive Soils				Cohesive Soils			
		V. Loose	Loose	Medium	Dense	V. Soft	Soft	Medium	Stiff
 <p>Fixed Head Condition</p> <p>Pile Head Restrained Against Rotation</p>	MH2325U	1,000	1,700	2,300	3,000	600	1,500	2,500	3,800
	MH222U	1,300	2,200	3,100	3,800	800	1,800	3,200	4,800
	MH227U	1,400	2,400	3,400	4,500	800	1,900	3,400	5,500
	MH313B/BR	1,100	1,700	2,000	2,300	800	1,600	2,300	3,100
	MH325B/BR	1,500	2,500	3,300	3,800	900	2,000	3,500	4,700
	MH3521U	1,700	3,000	4,200	5,100	1,100	2,300	4,000	6,200
	MH3530U	1,900	3,500	4,900	6,600	1,100	2,500	4,400	7,700
	MH429U/Y	2,800	5,100	7,100	9,600	1,600	3,400	6,100	10,500
	MH434U	3,000	5,400	7,500	10,300	1,700	3,500	6,300	11,000
	MH530Y	3,800	7,000	9,700	13,000	2,100	4,400	7,900	13,500
	MH536Y	4,100	7,500	10,400	14,000	2,200	4,700	8,300	14,200
	MH542Y	4,300	8,000	11,000	15,000	2,300	4,800	8,600	14,900
	MH547Y	4,500	8,300	11,500	15,700	2,400	5,000	8,900	15,300
	MH736U	5,800	10,900	15,000	20,400	3,100	6,300	11,300	19,500
	MH740U	6,000	11,500	15,800	21,400	3,200	6,500	11,600	20,000
	MH745U/Y	6,300	11,900	16,500	22,400	3,300	6,700	12,000	20,500
	MH850Q	8,700	16,800	23,000	26,800	4,400	8,900	16,200	27,000
	MH939U	9,300	17,800	24,700	33,800	4,800	9,600	17,400	29,800
	MH1050U	11,500	23,000	31,800	43,500	5,900	11,800	21,300	36,500
	MH1250Q	14,400	29,200	39,500	45,200	7,300	14,600	26,500	44,400
MH1338Q	13,800	28,000	37,400	42,700	7,200	14,400	26,100	42,500	
MH1650U	19,000	40,000	50,000	56,700	9,800	19,500	35,500	55,000	
MH1843Q	21,500	47,000	65,000	78,700	11,400	22,700	41,500	70,500	
Minimum Pile Depth, h =		28d	28d	28d	28d	34d	34d	34d	34d

Index Soil Properties:	Non-Cohesive Soils				Cohesive Soils			
	V. Loose	Loose	Medium	Dense	V. Soft	Soft	Medium	Stiff
SPT Blow Count (bpf)	1-4	4-10	10-30	30-50	1-2	2-4	4-8	8-15
Strain, ϵ_{50}	N/A	N/A	N/A	N/A	0.06	0.02	0.01	0.005
p-y Modulus (pci)	5	25	90	225	30	100	500	1000
Cohesion (psf)	0	0	0	0	200	400	800	1500
Friction Angle (deg)	25	29	33	39	0	0	0	0
Unit Weight (pcf)	70	90	110	120	80	85	90	100

PILE HEAD FIXITY EXAMPLES

NOTE: MINIMUM EMBEDMENT REQUIREMENTS APPLY.

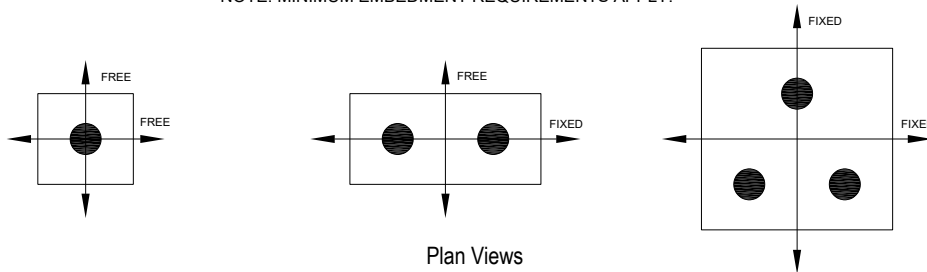

¹Allowable lateral capacity for round-shaft helical piles. Square shaft helical piles (MS150B and MS175B) have negligible lateral capacity

*Limitations: IBC2021 states that the allowable lateral capacity of a pile shall be half the load causing 1-inch of deflection. Many professionals use the lateral capacity at a deflection of 0.5 inches as the allowable lateral capacity. The allowable lateral capacities shown in these tables are based on a predicted deflection of 0.5 inches at the ground surface. Refer to MAGNUM® Technical Reference Manual for theoretical load displacement curves and for allowable capacities at other deflection limits. These capacity tables are based on lateral load applied at ground surface and galvanized shafts with 50 years corrosion in non-severe corrosive conditions. Contact MAGNUM® technical support professionals for lateral capacity when loads are applied above ground, for resistance to bending moments. Occasionally, annular space can develop around upper portions of the shaft when helical piles have multiple bolted couplings (all MAGNUM® helical piles larger than 3.5" diameter) or when installation methods cause excessive wobbling. It is recommended that any annular space be grouted from the surface using fast-setting, non-shrink, neat cement grout when lateral capacity is required.



Displacement Piles



Displacement Pile Number Specification Legend

Example

The MAGNUM® Displacement Pile product number below, MGL434U10L12S14S6G, is for a Propulsion Grout Lead with 4.5" diameter shaft, a 0.337" wall thickness, a Bolted connection, 10 ft. long with (2) 0.50" Single Edge Helices 12 and 14 inches in diameter with a 6" pitch, and the surface preparation is Galvanized.

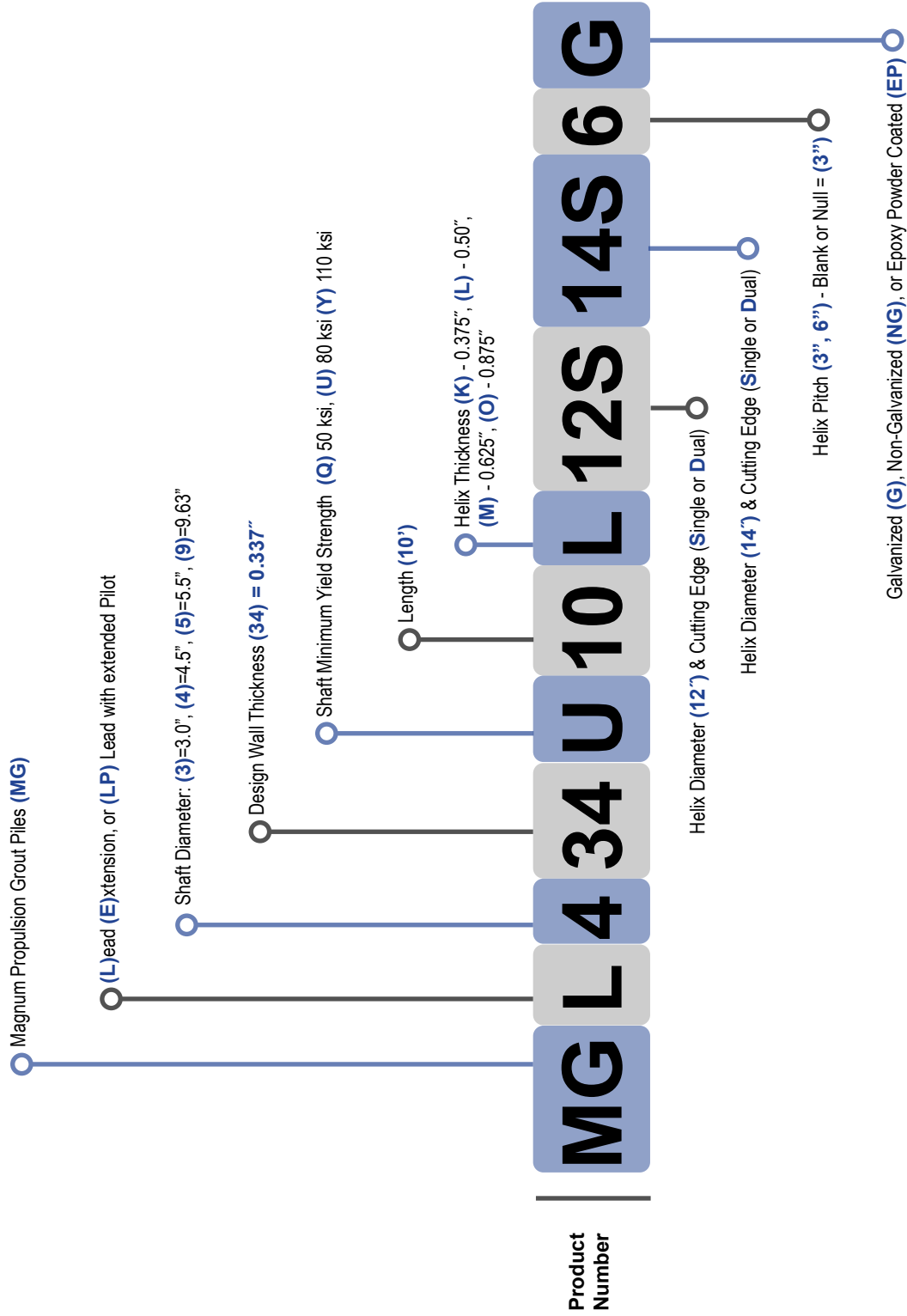

MAGNITUDE® Propulsion Grout Pile Installation Example

The MAGNITUDE® Propulsion Grout Pile consists of a helical pile lead section with displacement plates integrated with the helices that create a borehole around the shaft. Patent pending grout propellers spaced along extension shafts force grout down, into the borehole. To assure structural capacity, the central shaft acts as a permanent steel column stabilized by grout and is sized to carry all loads on the pile.

A shallow grout reservoir is created using a post hole auger. The diameter of the reservoir is at least a few inches larger than the helices. Once cured, the reservoir adds to lateral capacity.

The pile is then advanced one to two feet allowing the borehole to begin to form below the reservoir. Filling the reservoir with grout begins. Grout levels need to be maintained during installation.



Grout is propelled down the bore hole by turbine-like grout propellers arranged along the shaft. The grout propellers create downward pressure that continuously feeds grout down and keeps the bore hole open.

The large diameter helices pull the pile into the ground through the mechanical advantage of a ground screw. Rotation continues until reaching design depth or shaft torque rating.

The helical pile with grout propellers acts as a permanent reinforcing element for the grout column. The central steel shaft is sized to support structural loads.

MAGNITUDE® MG325BR Propulsion Grout Piles

Allowable Capacity 36 Tons - Ultimate Capacity 60 Tons

High-Strength 3.0" Diameter, 0.27" Wall, Center-Shaft with 8" Grout Column

Description: MAGNITUDE® Propulsion Grout Piles combine the unique benefits of helical installation with grouted displacement piles. MAGNUM® products are manufactured in the USA according to our ISO 9001 approved Quality Program. Our MAGNITUDE® piles utilize rigid bolted couplings to join extension sections and the lead section, extending the grout column and placing the helical bearing elements down to the desired bearing stratum. Structural capacities are developed according to AISC 360 and consider buckling length of 5 ft unbraced length. Grout displacement plates create an annular space which is filled by grout. Grout Propellers spaced along the pile shaft propel the grout down to improve grout take. Grout is utilized as ground improvement, adhesion and corrosion protection only. Required depth of the pile depends on ground conditions and should be determined for each site by a design professional.

1. **Patented Dual-Cutting Edge helical bearing plates (DCE) enhance penetration through dense soils with occasional cobbles and debris.**
2. **Patented Alternating Helix pattern reduces wobble and improves plumbness and tracking.**
3. **Displacement paddles in the helices create an annular space for the grout column.**
4. **Patented Grout Propellers force grout down into the annular space as the pile shaft rotates.**
5. **Evenly spaced Grout Propellers along the length of all extension sections ensure maximum grout take and true diameter of grout column.**

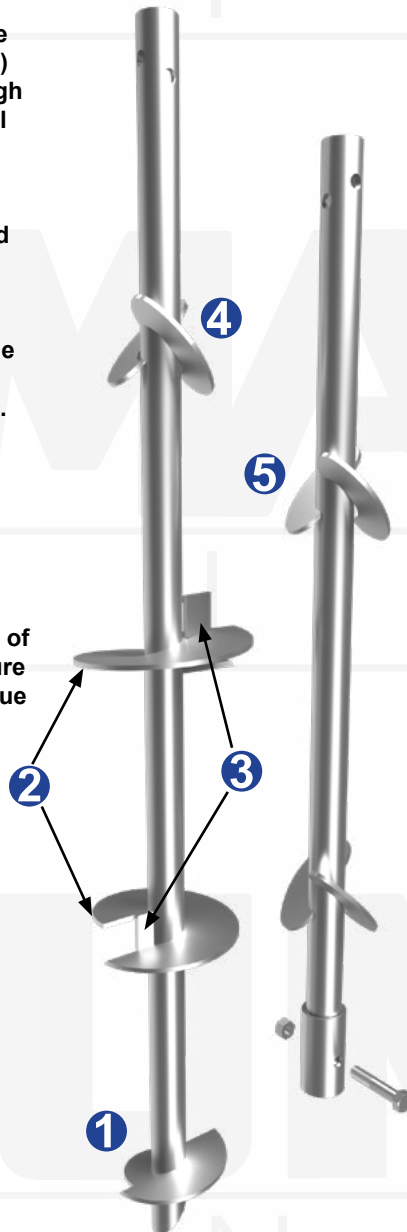

Properties	
Center Shaft	3.0" Dia. x 0.27" Wall
Helices	10D12S14S
Propellers	8" Dia. @ +/- 5 ft. O.C.
Max. Torque	12,500 ft-lbs
Grout Column	8" Dia.
Grout Reservoir	18" Dia. x 24" (typ)
Structural Capacity	
Allowable Tension	27 Tons
Allowable Compression	36 Tons
Ultimate Compression	60 Tons

Installation Notes: Begin by auguring a grout reservoir and fill with high-mobility neat cement or sanded grout. Case reservoir if needed to prevent caving and water intrusion. Install MAGNITUDE® propulsion grout piles through the reservoir. Displacement plates clear a path for the grout column. Propellers force grout to follow. Apply crowd and torque as needed to advance pile. Continuously supply grout to reservoir. Add extensions to reach required depth. Monitor and maintain position and desired inclination.

MAGNITUDE[®] MG434U Propulsion Grout Piles

Allowable Capacity 93 Tons - Ultimate Capacity 156 Tons

High-Strength 4.5" Diameter, 0.337" Wall, Center-Shaft with 10" Grout Column

Description: MAGNITUDE[®] Propulsion Grout Piles combine the unique benefits of helical installation with grouted displacement piles. MAGNUM[®] products are manufactured in the USA according to our ISO 9001 approved Quality Program. Our MAGNITUDE[®] piles utilize rigid bolted couplings to join extension sections and the lead section, extending the grout column and placing the helical bearing elements down to the desired bearing stratum. Structural capacities are developed according to AISC 360 and consider buckling length of 5 ft unbraced length. Grout displacement plates create an annular space which is filled by grout. Grout Propellers spaced along the pile shaft propel the grout down to improve grout take. Grout is utilized as ground improvement, adhesion and corrosion protection only. Required depth of the pile depends on ground conditions and should be determined for each site by a design professional.

1. **Patented Dual-Cutting Edge helical bearing plates (DCE) enhance penetration through dense soils with occasional cobbles and debris.**
2. **Patented Alternating Helix pattern reduces wobble and improves plumbness and tracking.**
3. **Displacement paddles in the helices create an annular space for the grout column.**
4. **Patented Grout Propellers force grout down into the annular space as the pile shaft rotates.**
5. **Evenly spaced Grout Propellers along the length of all extension sections ensure maximum grout take and true diameter of grout column.**

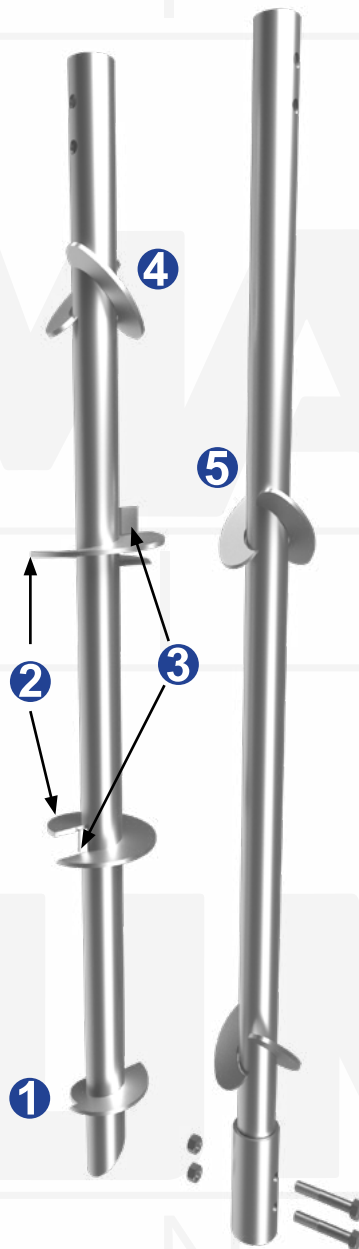

Properties	
Center Shaft	4.5" Dia. x 0.337" Wall
Helices	12D14S16S
Propellers	10" Dia. @ +/- 6 ft O.C.
Max. Torque	29,700 ft-lbs
Grout Column	10" Dia.
Grout Reservoir	18" Dia. x 24" (min)
Structural Capacity	
Allowable Tension	65 Tons
Allowable Compression	93 Tons
Ultimate Compression	156 Tons

Installation Notes: Begin by auguring a grout reservoir and fill with high-mobility neat cement or sanded grout. Case reservoir if needed to prevent caving and water intrusion. Install MAGNITUDE[®] propulsion grout piles through the reservoir. Displacement plates clear a path for the grout column. Propellers force grout to follow. Apply crowd and torque as needed to advance pile. Continuously supply grout to reservoir. Add extensions to reach required depth. Monitor and maintain position and desired inclination.

Grout Piles



156 Circle Freeway Dr.
Cincinnati, OH 45246
800-822-7437
www.MagnumPiering.com

MAGNITUDE® MG536Y-6 Propulsion Grout Piles

Allowable Capacity 172 Tons - Ultimate Capacity 287 Tons

High-Strength 5.5" Diameter, 0.36" Wall, Center-Shaft with 14" Grout Column

Description: MAGNITUDE® Propulsion Grout Piles combine the unique benefits of helical installation with grouted displacement piles. MAGNUM® products are manufactured in the USA according to our ISO 9001 approved Quality Program. Our MAGNITUDE® piles utilize rigid bolted couplings to join extension sections and the lead section, extending the grout column and placing the helical bearing elements down to the desired bearing stratum. Structural capacities are developed according to AISC 360 and consider buckling length of 5 ft unbraced length. Grout displacement plates create an annular space which is filled by grout. Grout Propellers spaced along the pile shaft propel the grout down to improve grout take. Grout is utilized as ground improvement, adhesion and corrosion protection only. Required depth of the pile depends on ground conditions and should be determined for each site by a design professional.

1. **Patented Dual-Cutting Edge helical bearing plates (DCE) enhance penetration through dense soils with occasional cobbles and debris.**
2. **Patented Alternating Helix pattern reduces wobble and improves plumbness and tracking.**
3. **Displacement paddles in the helices create an annular space for the grout column.**
4. **Patented Grout Propellers force grout down into the annular space as the pile shaft rotates.**
5. **Evenly spaced Grout Propellers along the length of all extension sections ensure maximum grout take and true diameter of grout column.**

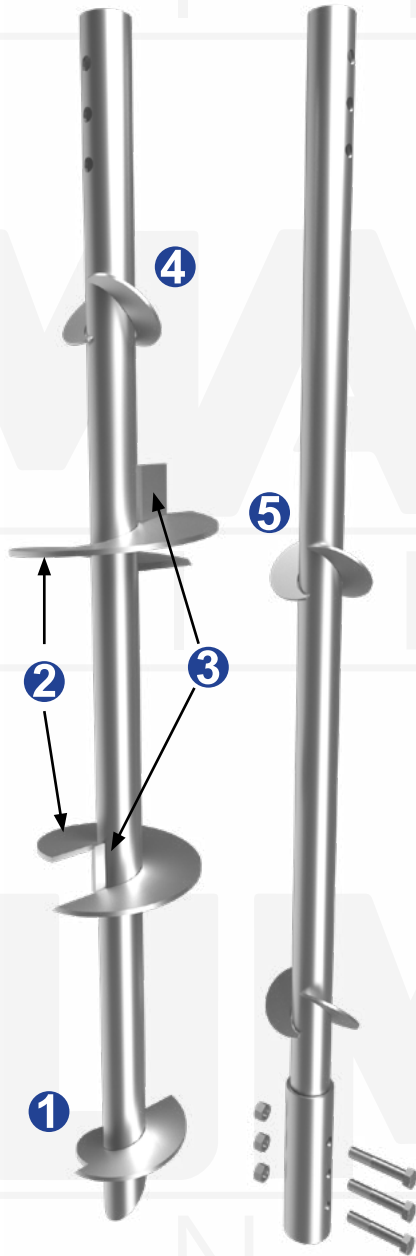

Properties	
Center Shaft	5.5" Dia. x 0.36" Wall
Helices	16D20S24S
Propellers	14" Dia. @ +/- 6 ft O.C.
Max. Torque	65,300 ft-lbs
Grout Column	14" Dia.
Grout Reservoir	26" Dia. x 24" (min)
Structural Capacity	
Allowable Tension	140 Tons
Allowable Compression	172 Tons
Ultimate Compression	287 Tons

Installation Notes: Begin by auguring a grout reservoir and fill with high-mobility neat cement or sanded grout. Case reservoir if needed to prevent caving and water intrusion. Install MAGNITUDE® propulsion grout piles through the reservoir. Displacement plates clear a path for the grout column. Propellers force grout to follow. Apply crowd and torque as needed to advance pile. Continuously supply grout to reservoir. Add extensions to reach required depth. Monitor and maintain position and desired inclination.

MAGNITUDE[®] MG542Y-6 Propulsion Grout Piles

Allowable Capacity 195 Tons - Ultimate Capacity 325 Tons

High-Strength 5.5" Diameter, 0.415" Wall, Center-Shaft with 14" Grout Column

Description: MAGNITUDE[®] Propulsion Grout Piles combine the unique benefits of helical installation with grouted displacement piles. MAGNUM[®] products are manufactured in the USA according to our ISO 9001 approved Quality Program. Our MAGNITUDE[®] piles utilize rigid bolted couplings to join extension sections and the lead section, extending the grout column and placing the helical bearing elements down to the desired bearing stratum. Structural capacities are developed according to AISC 360 and consider buckling length of 5 ft unbraced length. Grout displacement plates create an annular space which is filled by grout. Grout Propellers spaced along the pile shaft propel the grout down to improve grout take. Grout is utilized as ground improvement, adhesion and corrosion protection only. Required depth of the pile depends on ground conditions and should be determined for each site by a design professional.

1. **Patented Dual-Cutting Edge helical bearing plates (DCE) enhance penetration through dense soils with occasional cobbles and debris.**
2. **Patented Alternating Helix pattern reduces wobble and improves plumbness and tracking.**
3. **Displacement paddles in the helices create an annular space for the grout column.**
4. **Patented Grout Propellers force grout down into the annular space as the pile shaft rotates.**
5. **Evenly spaced Grout Propellers along the length of all extension sections ensure maximum grout take and true diameter of grout column.**

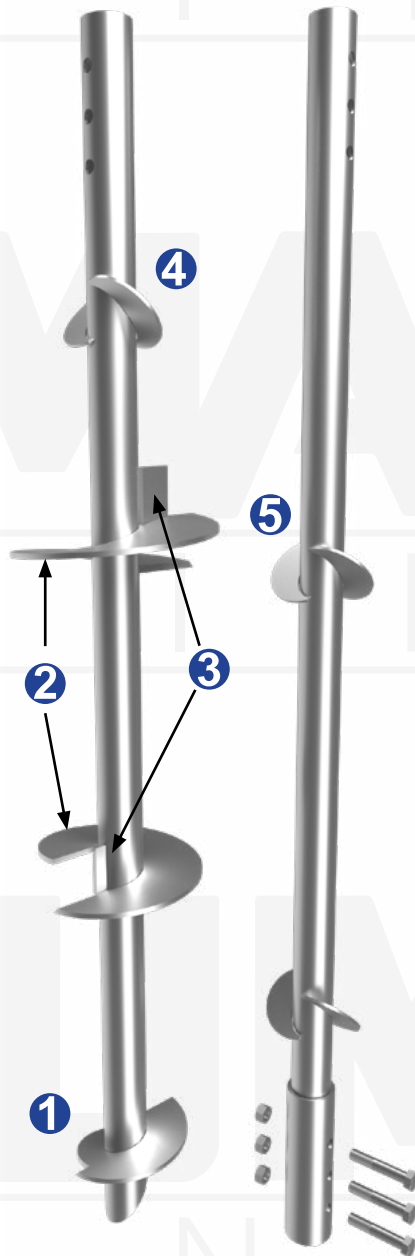

Properties	
Center Shaft	5.5" Dia. x 0.415" Wall
Helices	16D20S24S
Propellers	14" Dia. @ +/- 6 ft O.C.
Max. Torque	73,400 ft-lbs
Grout Column	14" Dia.
Grout Reservoir	26" Dia. x 24" (min)
Structural Capacity	
Allowable Tension	141 Tons
Allowable Compression	195 Tons
Ultimate Compression	325 Tons

Installation Notes: Begin by auguring a grout reservoir and fill with high-mobility neat cement or sanded grout. Case reservoir if needed to prevent caving and water intrusion. Install MAGNITUDE[®] propulsion grout piles through the reservoir. Displacement plates clear a path for the grout column. Propellers force grout to follow. Apply crowd and torque as needed to advance pile. Continuously supply grout to reservoir. Add extensions to reach required depth. Monitor and maintain position and desired inclination.

Grout Piles

MAGNATUDE® MG547Y-6 Propulsion Grout Piles

Allowable Capacity 220 Tons - Ultimate Capacity 368 Tons

High-Strength 5.5" Diameter, 0.47" Wall, Center-Shaft with 16" Grout Column

Description: MAGNATUDE® Propulsion Grout Piles combine the unique benefits of helical installation with grouted displacement piles. MAGNUM® products are manufactured in the USA according to our ISO 9001 approved Quality Program. Our MAGNATUDE® piles utilize rigid bolted couplings to join extension sections and the lead section, extending the grout column and placing the helical bearing elements down to the desired bearing stratum. Structural capacities are developed according to AISC 360 and consider buckling length of 5 ft unbraced length. Grout displacement plates create an annular space which is filled by grout. Grout Propellers spaced along the pile shaft propel the grout down to improve grout take. Grout is utilized as ground improvement, adhesion and corrosion protection only. Required depth of the pile depends on ground conditions and should be determined for each site by a design professional.

1. **Patented Dual-Cutting Edge helical bearing plates (DCE) enhance penetration through dense soils with occasional cobbles and debris.**
2. **Patented Alternating Helix pattern reduces wobble and improves plumbness and tracking.**
3. **Displacement paddles in the helices create an annular space for the grout column.**
4. **Patented Grout Propellers force grout down into the annular space as the pile shaft rotates.**
5. **Evenly spaced Grout Propellers along the length of all extension sections ensure maximum grout take and true diameter of grout column.**

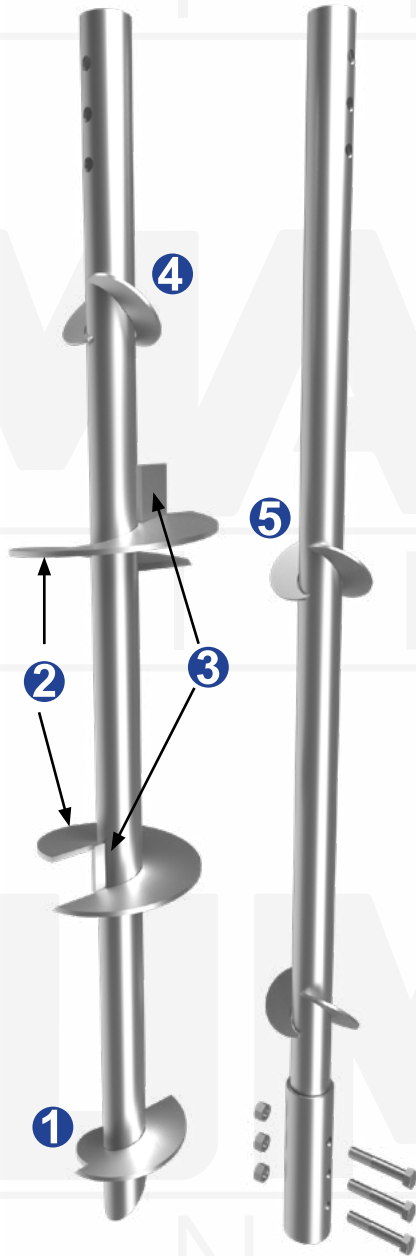

Properties	
Center Shaft	5.5" Dia. x 0.47" Wall
Helices	20D24S30S
Propellers	16" Dia. @ +/- 7 ft O.C.
Max. Torque	82,000 ft-lbs
Grout Column	16" Dia.
Grout Reservoir	32" Dia. x 24" (min)
Structural Capacity	
Allowable Tension	141 Tons
Allowable Compression	220 Tons
Ultimate Compression	368 Tons

Installation Notes: Begin by auguring a grout reservoir and fill with high-mobility neat cement or sanded grout. Case reservoir if needed to prevent caving and water intrusion. Install MAGNATUDE® propulsion grout piles through the reservoir. Displacement plates clear a path for the grout column. Propellers force grout to follow. Apply crowd and torque as needed to advance pile. Continuously supply grout to reservoir. Add extensions to reach required depth. Monitor and maintain position and desired inclination.

MAGNATUDE® MG939U-6 Propulsion Grout Piles

Allowable Capacity 267 Tons - Ultimate Capacity 447 Tons

High-Strength 9.6" Diameter, 0.39" Wall, Center-Shaft with 22" Grout Column

Description: MAGNATUDE® Propulsion Grout Piles combine the unique benefits of helical installation with grouted displacement piles. MAGNUM® products are manufactured in the USA according to our ISO 9001 approved Quality Program. Our MAGNATUDE® piles utilize rigid bolted couplings to join extension sections and the lead section, extending the grout column and placing the helical bearing elements down to the desired bearing stratum. Structural capacities are developed according to AISC 360 and consider buckling length of 5 ft unbraced length. Grout displacement plates create an annular space which is filled by grout. Grout Propellers spaced along the pile shaft propel the grout down to improve grout take. Grout is utilized as ground improvement, adhesion and corrosion protection only. Required depth of the pile depends on ground conditions and should be determined for each site by a design professional.

1. **Patented Dual-Cutting Edge helical bearing plates (DCE) enhance penetration through dense soils with occasional cobbles and debris.**
2. **Patented Alternating Helix pattern reduces wobble and improves plumbness and tracking.**
3. **Displacement paddles in the helices create an annular space for the grout column.**
4. **Patented Grout Propellers force grout down into the annular space as the pile shaft rotates.**
5. **Evenly spaced Grout Propellers along the length of all extension sections ensure maximum grout take and true diameter of grout column.**

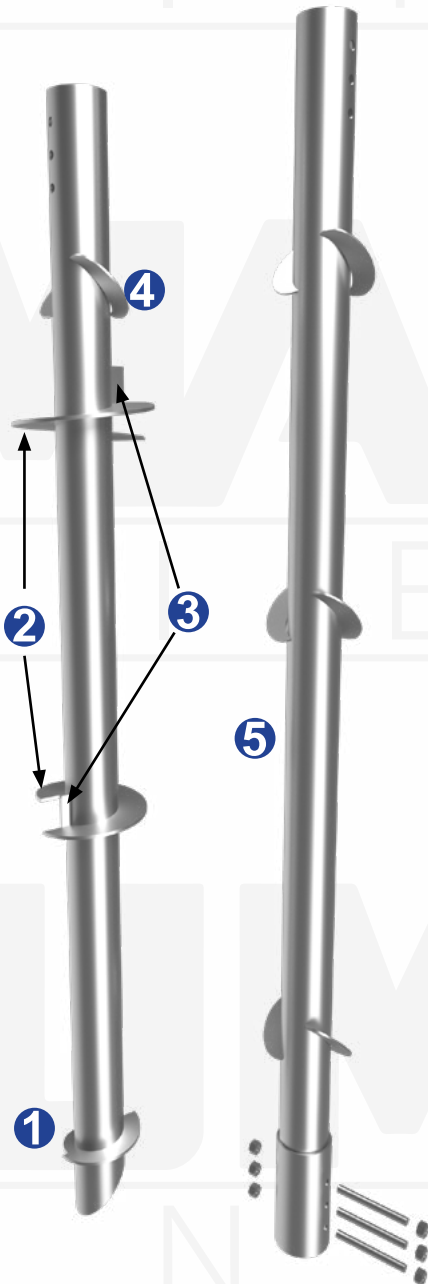

Properties	
Center Shaft	9.63" Dia. x 0.39" Wall
Helices	24D30D36S
Propellers	22" Dia. @ +/- 7 ft O.C.
Max. Torque	192,100 ft-lbs
Grout Column	22" Dia.
Grout Reservoir	38" Dia. x 24" (min)
Structural Capacity	
Allowable Tension	168 Tons
Allowable Compression	267 Tons
Ultimate Compression	447 Tons

Installation Notes: Begin by auguring a grout reservoir and fill with high-mobility neat cement or sanded grout. Case reservoir if needed to prevent caving and water intrusion. Install MAGNATUDE® propulsion grout piles through the reservoir. Displacement plates clear a path for the grout column. Propellers force grout to follow. Apply crowd and torque as needed to advance pile. Continuously supply grout to reservoir. Add extensions to reach required depth. Monitor and maintain position and desired inclination.

Grout Piles

U.S. Patents 6,058,662, D612,954, Other Patents Pending



156 Circle Freeway Dr.
Cincinnati, OH 45246
800-822-7437
www.MagnumPiering.com

Push Piers & Jacked Piles

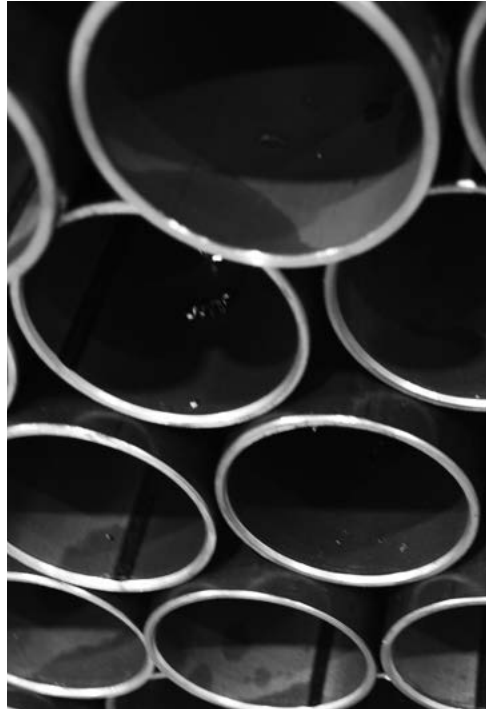

Steel Push Pier Number Specification Legend



Example

The MAGNUM® Push Pier product number below **MP313-36G** is for a Push Pier section with 3.00" diameter shaft, a 0.13" wall thickness, is 36" long, and the surface preparation is Galvanized.

Note: See "Magnum Piering Push Pier Specifications" table on next page for detailed information. Specification information is also available at www.magnumpiering.com

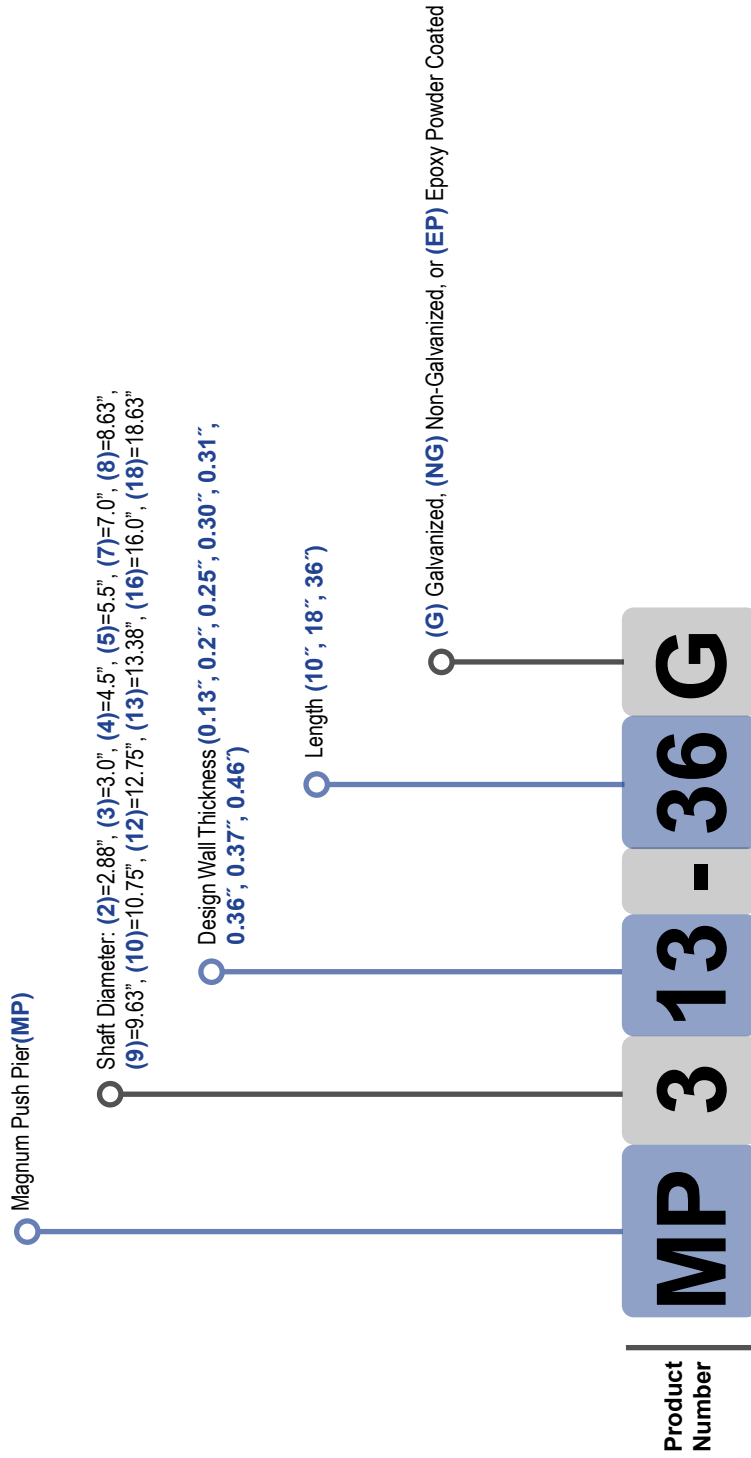

Push Pier Specifications

System Ratings & Specifications



Push Pier	Shaft Design Wall Gauge (in)	Shaft O.D. (in)	Galvanized		Bare Steel		Max. Test Load** (tons)	Max. Allowable Load from Test w/ F.S. = 1.5 (tons)	Piston Area	Max Test Pressure	Max Ram Load	Surface Coating***	Standard Section Lengths (in.)
			Ultimate (tons)	Allowable (tons)	Ultimate (tons)	Allowable (tons)							
MP212R	0.12	1.75	10	6	6	3.5	9	6	3.14	5700	9	G, NG	18, 36
MP222U	0.217	2.875	52	31	41	25	48	32	8.3	7500	31	G, NG	18, 36
MP313R	0.13	3	28	17	18	11	28	18	8.3	6700	28	G, NG	18, 36
MP325R	0.27	3	58	35	49	29	54	36	8.3	7500	31	G, NG	18, 36
MP3521Q	0.21	3.5	47	28	37	22	43	29	8.3	7500	31	G, NG	18, 36
MP3525U	0.254	3.5	83	49	68	40.5	76	51	8.3	7500	31	G, NG	18, 36
MP429U	0.29	4.5	133	80	113	67	122	81	8.3	7500	31	G, NG	18, 36
MP434U	0.34	4.5	153	92	133	79	140	93	8.3	7500	31	G, NG	18, 36
MP212R-S	0.12	1.75	10	6	6	3.5	9	6	3.14	5700	9	G, NG	9, 18
MP222U-S	0.217	2.875	52	31	41	25	48	32	8.3	7500	31	G, NG	9, 18
MP313R-S	0.13	3	28	17	18	11	28	18	8.3	6700	28	G, NG	10, 18
MP325R-S	0.27	3	58	35	49	29	54	36	8.3	7500	31	G, NG	10, 18
MP3521Q-S	0.21	3.5	47	28	37	22	43	29	8.3	7500	31	G, NG	10, 18
MP3525U-S	0.254	3.5	83	49	68	40.5	76	51	8.3	7500	31	G, NG	10, 18
MP429U-S	0.29	4.5	133	80	113	67	122	81	8.3	7500	31	G, NG	10, 18
MP434U-S	0.34	4.5	153	92	133	79	140	93	8.3	7500	31	G, NG	10, 18

Notes:

*Structural capacity is the theoretical buckling strength of the shaft in firm soils with fixed head conditions (60 in unbraced length, K=0.80). The calculation takes into account corrosion per ICC-ES AC308 and represents the capacity after corrosion has occurred. Buckling capacity will be less in soft soils, when any part of the shaft is standing unsupported in air, water or fluid soils, or if head conditions differ.

**Maximum test load is based on maximum ram pressure times piston area. Ram pressure is limited to that which would buckle the pile or the maximum safe operating pressure of the system, whichever is less. The strength of the push pier system may be governed by the bracket, connection of the bracket to the pier, or connection of the bracket to the structure. All push piers should be load tested to 1.5 times the desired design/working load.

***G = Hot-Dip Zinc Galvanized per ASTM A123/A153, NG = Bare Steel, EP = Epoxy Powder Coated per ICC-ES AC228

All MAGNUM® Push Pier products are manufactured using ASTM A513 Grade 65 ksi minimum yield strength structural tubing. As MAGNUM® is committed to testing and improving products, these specifications are subject to change. Additional product specifications are available at www.magnumpiering.com and upon request.

Push Pier Friction Lead Specifications

System Ratings & Specifications

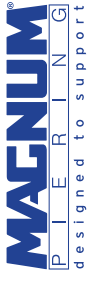

Friction Lead	Description	Shaft Design Wall Gauge (in)	Bearing Ring O.D. (in)	Maximum Allowable Load from Test w / F.S. =1.5 (tons)	Surface Coating*	Length (in)	Schematic
MP212-FL	2" Friction Lead for MP212 Push Pier	0.12	2	4	NG, G, EP	3	
MP313-FL	3.5" Friction Lead for MP313 Push Pier	0.13	3.5	11	NG, G, EP	3	
MP325-FL	3.5" Friction Lead for MP325 Push Pier	0.25	3.5	21	NG, G, EP	3	
MP313-FL5	5" Friction Lead for MP313 Push Pier	0.13	5	11	NG, G, EP	3	
MP325-FL5	5" Friction Lead for MP325 Push Pier	0.25	5	21	NG, G, EP	3	
MP419-FL	5" Friction Lead for MP419 Push Pier	0.19	5	21	NG, G, EP	3	
MP425-FL	5" Friction Lead for MP425 Push Pier	0.25	5	40	NG, G, EP	3	
MP431-FL	5" Friction Lead for MP431 Push Pier	0.31	5	40	NG, G, EP	3	

Notes:

*G = Hot-Dip Zinc Galvanized per ASTM A123/A153, NG = Bare Steel, EP = Epoxy Powder Coated per ICC-ES AC228

All MAGNUM® Push Pier products are manufactured using ASTM A513 Grade 65 ksi minimum yield strength structural tubing. As MAGNUM® is committed to testing and improving products, these specifications are subject to change. Additional product specifications are available at www.magnumpiering.com and upon request.

MAGNUM® Push Pier Sizing Guide

MP Series Push Piers

Estimated MP313/MP325 Steel Push Pier Penetration into Soil

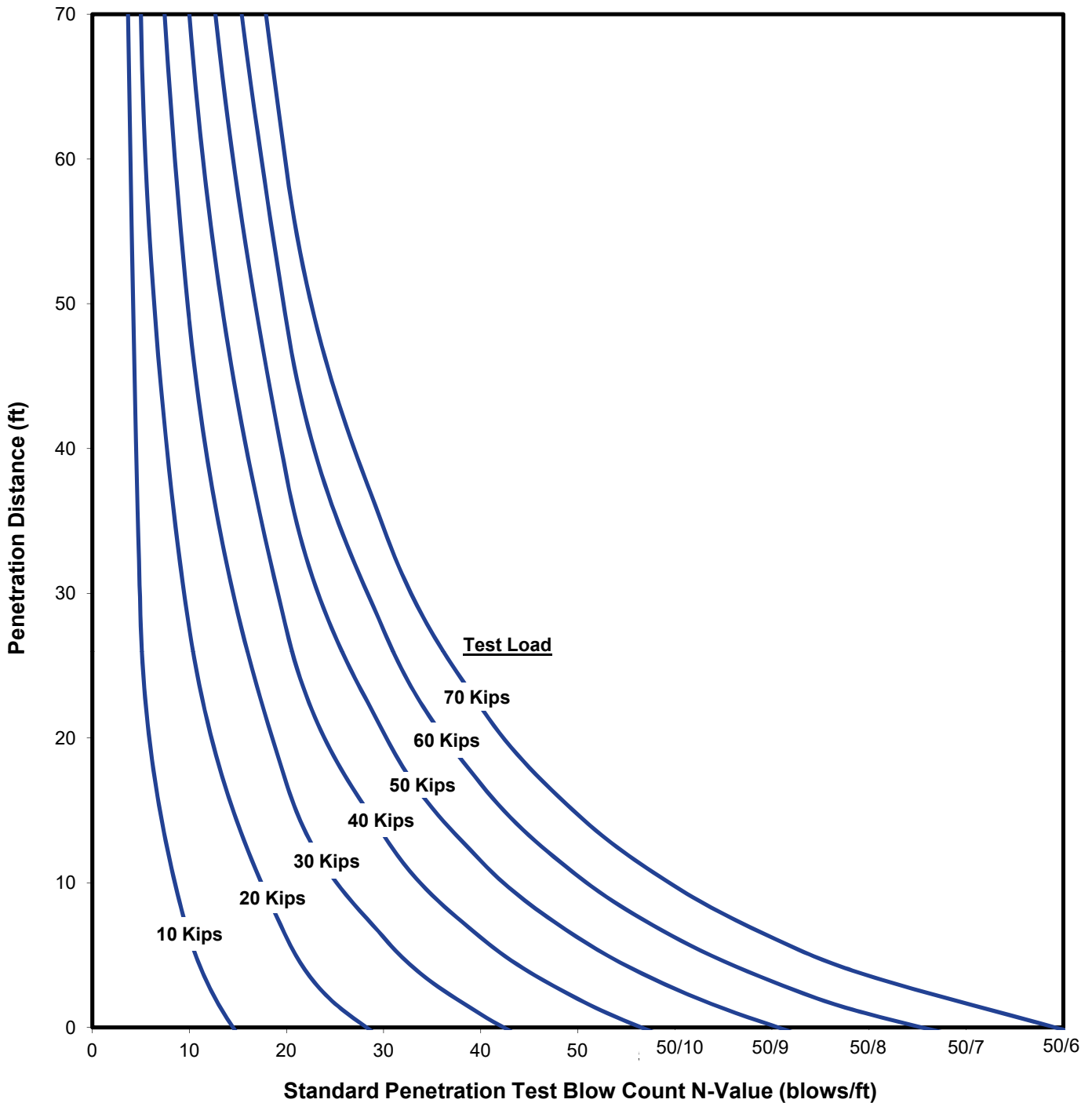

Limitations: This chart is based on empirical data from 1,502 push pier load tests. Despite the large amount of data, there exists considerable variation in the data. This chart can be used to assist with estimating pile lengths as a base-line for material takeoffs. Actual site conditions may vary. A load test should be performed at each push pier location to verify capacity. Contractor is advised to keep an inventory of materials in case site conditions require additional pile depth.

MAGNUM® MP212R Push Pier

Up to 6 Tons Allowable Capacity in Compression

High-Strength 1.75" Diameter, 0.12" Wall, Round-Shaft Push Piers with Male-Female Slip Connectors

Description: MAGNUM® Push Pier sections couple together with male-female slip connectors. High strength steel offers increased buckling resistance compared to others. A friction reduction collar can be added to the pile to increase penetration depth. Structural capacities are developed according to AISC 360 and ICC-AC517 considering buckling of 5 ft unbraced length after 75 years of corrosion in moderate to high aggressive soils for various material coatings. Custom lengths are available upon request. See MAGNUM® Technical Manual for additional information.



Steel Specifications			
Shaft	HSS 1.75" x 0.12" wall ASTM A513, Fy = 65 ksi, or Equivalent		
Coating	Hot-Dip Galvanized (G) or Bare Steel (NG)		
Section Properties	New	Galvanized (G)	Bare Steel (NG)
I	0.21	0.19	0.12
A _g	0.61	0.59	0.36
S	0.23	0.22	0.14
Structural Capacity In Compression*			
Ultimate Capacity	10 Tons	10 Tons	6 Tons
Allowable Capacity		6 Tons	3.6 Tons
Capacity From Load Test**			
Maximum Test Load	9 Tons		
Allowable Capacity	6 Tons		
Standard Ram	3.14 sq. in Piston Area, 7,500 Maximum P.S.I. (5,700 Max. P.S.I. Installation Pressure**)		

* Push piers shall be installed to appropriate depth into suitable bearing stratum as determined by geotechnical engineer or local practice. For tension capacity, push pier sections must be welded together or a reinforcing steel bar and grout must be placed in the pile.

** Push pier geotechnical capacity is determined by load test using MAGNUM® Installation Rams or Lifting Kit. All push piers shall be load tested to 1.5 times the desired working load. Test load is limited by maximum safe operating ram pressure or buckling capacity of shaft, whichever is less.

U.S. Patents 5,234,287, 4,708,528, 5,123,209

MAGNUM®
P I E R I N G
designed to support

156 Circle Freeway Dr.
Cincinnati, OH 45246
800-822-7437
www.MagnumPiering.com

MAGNUM® MP222U Push Pier

Up to 31 Tons Allowable Capacity in Compression

High-Strength 2.875" Diameter, 0.217" Wall, Round-Shaft Push Piers with Male-Female Slip Connectors

Description: MAGNUM® Push Pier sections couple together with male-female slip connectors. High strength steel offers increased buckling resistance compared to others. A friction reduction collar can be added to the pile to increase penetration depth. Structural capacities are developed according to AISC 360 and ICC-AC517 considering buckling of 5 ft unbraced length after 75 years of corrosion in moderate to high aggressive soils for various material coatings. Custom lengths are available upon request. See MAGNUM® Technical Manual for additional information.



Steel Specifications			
Shaft	HSS 2.875" x 0.217" wall ASTM A252, Fy = 80 ksi, or Equivalent		
Coating	Hot-Dip Galvanized (G) or Bare Steel (NG)		
Section Properties	New	Galvanized (G)	Bare Steel (NG)
I	1.61	1.56	1.24
A _g	1.81	1.77	1.4
S	1.12	1.09	0.88
Structural Capacity In Compression*			
Ultimate Capacity	54 Tons	52 Tons	41 Tons
Allowable Capacity		31 Tons	25 Tons
Capacity From Load Test**			
Maximum Test Load	48 Tons		
Allowable Capacity	32 Tons		
Standard Ram	8.30 sq. in Piston Area, 7,500 Maximum P.S.I.		

* Push piers shall be installed to appropriate depth into suitable bearing stratum as determined by geotechnical engineer or local practice. For tension capacity, push pier sections must be welded together or a reinforcing steel bar and grout must be placed in the pile.

** Push pier geotechnical capacity is determined by load test using MAGNUM® Installation Rams or Lifting Kit. All push piers shall be load tested to 1.5 times the desired working load. Test load is limited by maximum safe operating ram pressure or buckling capacity of shaft, whichever is less.

U.S. Patents 5,234,287, 4,708,528, 5,123,209



156 Circle Freeway Dr.
Cincinnati, OH 45246
800-822-7437
www.MagnumPiering.com

MAGNUM® MP313R Push Pier

Up to 17 Tons Allowable Capacity in Compression

High-Strength 3.00" Diameter, 0.13" Wall, Round-Shaft Push Piers with Male-Female Slip Connectors

Description: MAGNUM® Push Pier sections couple together with male-female slip connectors. High strength steel offers increased buckling resistance compared to others. A friction reduction collar can be added to the pile to increase penetration depth. Structural capacities are developed according to AISC 360 and ICC-AC517 considering buckling of 5 ft unbraced length after 75 years of corrosion in moderate to high aggressive soils for various material coatings. Custom lengths are available upon request. See MAGNUM® Technical Manual for additional information.



Steel Specifications			
Shaft	HSS 3.00" x 0.13" Wall ASTM A513, Fy = 65 ksi, or Equivalent		
Coating	Hot-Dip Galvanized (G) or Bare Steel (NG)		
Section Properties	New	Galvanized (G)	Bare Steel (NG)
I	1.17	1.11	0.7
A _g	1.13	1.08	0.68
S	0.78	0.75	0.48
Structural Capacity In Compression*			
Ultimate Capacity	30 Tons	28 Tons	18 Tons
Allowable Capacity		17 Tons	11 Tons
Capacity From Load Test**			
Maximum Test Load	27 Tons		
Allowable Capacity	18 Tons		
Standard Ram	8.30 sq. in Piston Area, 7,500 Maximum P.S.I. (6,700 Max. P.S.I. Installation Pressure**)		

* Push piers shall be installed to appropriate depth into suitable bearing stratum as determined by geotechnical engineer or local practice. For tension capacity, push pier sections must be welded together or a reinforcing steel bar and grout must be placed in the pile.

** Push pier geotechnical capacity is determined by load test using MAGNUM® Installation Rams or Lifting Kit. All push piers shall be load tested to 1.5 times the desired working load. Test load is limited by maximum safe operating ram pressure or buckling capacity of shaft, whichever is less.

U.S. Patents 5,234,287, 4,708,528, 5,123,209



156 Circle Freeway Dr.
Cincinnati, OH 45246
800-822-7437
www.MagnumPiering.com

MAGNUM® MP325R Push Pier

Up to 35 Tons Allowable Capacity in Compression

High-Strength 3.00" Diameter, 0.25" Wall, Round-Shaft Push Piers with Male-Female Slip Connectors

Description: MAGNUM® Push Pier sections couple together with male-female slip connectors. High strength steel offers increased buckling resistance compared to others. A friction reduction collar can be added to the pile to increase penetration depth. Structural capacities are developed according to AISC 360 and ICC-AC517 considering buckling of 5 ft unbraced length after 75 years of corrosion in moderate to high aggressive soils for various material coatings. Custom lengths are available upon request. See MAGNUM® Technical Manual for additional information.



Steel Specifications			
Shaft	HSS 3.00" x 0.25" Wall ASTMA513, Fy = 65 ksi, or Equivalent		
Coating	Hot-Dip Galvanized (G) or Bare Steel (NG)		
Section Properties	New	Galvanized (G)	Bare Steel (NG)
I	2.18	2.12	1.77
A _g	2.32	2.27	1.89
S	1.45	1.42	1.2
Structural Capacity In Compression*			
Ultimate Capacity	60 Tons	58 Tons	49 Tons
Allowable Capacity		35 Tons	29 Tons
Capacity From Load Test**			
Maximum Test Load	54 Tons		
Allowable Capacity	36 Tons		
Standard Ram	8.30 sq. in Piston Area, 7,500 Maximum P.S.I.		

* Push piers shall be installed to appropriate depth into suitable bearing stratum as determined by geotechnical engineer or local practice. For tension capacity, push pier sections must be welded together or a reinforcing steel bar and grout must be placed in the pile.

** Push pier geotechnical capacity is determined by load test using MAGNUM® Installation Rams or Lifting Kit. All push piers shall be load tested to 1.5 times the desired working load. Test load is limited by maximum safe operating ram pressure or buckling capacity of shaft, whichever is less.

U.S. Patents 5,234,287, 4,708,528, 5,123,209



156 Circle Freeway Dr.
Cincinnati, OH 45246
800-822-7437
www.MagnumPiering.com

MAGNUM® MP3521Q Push Pier

Up to 28 Tons Allowable Capacity in Compression

Standard 3.50" Diameter, 0.21" Wall, Round-Shaft Push Piers with Male-Female Slip Connectors

Description: MAGNUM® Push Pier sections couple together with male-female slip connectors. High strength steel offers increased buckling resistance compared to others. A friction reduction collar can be added to the pile to increase penetration depth. Structural capacities are developed according to AISC 360 and ICC-AC517 considering buckling of 5 ft unbraced length after 75 years of corrosion in moderate to high aggressive soils for various material coatings. Custom lengths are available upon request. See MAGNUM® Technical Manual for additional information.



Steel Specifications			
Shaft	HSS 3.50" x 0.21" Wall ASTM A252, Fy = 50 ksi, or Equivalent		
Coating	Hot-Dip Galvanized (G) or Bare Steel (NG)		
Section Properties	New	Galvanized (G)	Bare Steel (NG)
I	2.95	2.86	2.25
A _g	2.17	2.11	1.66
S	1.68	1.64	1.3
Structural Capacity In Compression*			
Ultimate Capacity	48 Tons	47 Tons	37 Tons
Allowable Capacity		28 Tons	22 Tons
Capacity From Load Test**			
Maximum Test Load	43 Tons		
Allowable Capacity	29 Tons		
Standard Ram	8.30 sq. in Piston Area, 7,500 Maximum P.S.I.		

* Push piers shall be installed to appropriate depth into suitable bearing stratum as determined by geotechnical engineer or local practice. For tension capacity, push pier sections must be welded together or a reinforcing steel bar and grout must be placed in the pile.

** Push pier geotechnical capacity is determined by load test using MAGNUM® Installation Rams or Lifting Kit. All push piers shall be load tested to 1.5 times the desired working load. Test load is limited by maximum safe operating ram pressure or buckling capacity of shaft, whichever is less.

U.S. Patents 5,234,287, 4,708,528, 5,123,209

MAGNUM®
P I E R I N G
designed to support

156 Circle Freeway Dr.
Cincinnati, OH 45246
800-822-7437
www.MagnumPiering.com

MAGNUM® MP3525U Push Pier

Up to 49 Tons Allowable Capacity in Compression

High-Strength 3.50" Diameter, 0.254" Wall, Round-Shaft Push Piers with Male-Female Slip Connectors

Description: MAGNUM® Push Pier sections couple together with male-female slip connectors. High strength steel offers increased buckling resistance compared to others. A friction reduction collar can be added to the pile to increase penetration depth. Structural capacities are developed according to AISC 360 and ICC-AC517 considering buckling of 5 ft unbraced length after 75 years of corrosion in moderate to high aggressive soils for various material coatings. Custom lengths are available upon request. See MAGNUM® Technical Manual for additional information.



Steel Specifications			
Shaft	HSS 3.50" x 0.254" Wall ASTM A252, Fy = 80 ksi, or Equivalent		
Coating	Hot-Dip Galvanized (G) or Bare Steel (NG)		
Section Properties	New	Galvanized (G)	Bare Steel (NG)
I	3.43	3.35	2.75
A _g	2.59	2.53	2.08
S	1.96	1.92	1.6
Structural Capacity In Compression*			
Ultimate Capacity	85 Tons	83 Tons	68 Tons
Allowable Capacity		49 Tons	41 Tons
Capacity From Load Test**			
Maximum Test Load	76 Tons		
Allowable Capacity	51 Tons		
Standard Ram	8.30 sq. in Piston Area, 7,500 Maximum P.S.I.		

* Push piers shall be installed to appropriate depth into suitable bearing stratum as determined by geotechnical engineer or local practice. For tension capacity, push pier sections must be welded together or a reinforcing steel bar and grout must be placed in the pile.

** Push pier geotechnical capacity is determined by load test using MAGNUM® Installation Rams or Lifting Kit. All push piers shall be load tested to 1.5 times the desired working load. Test load is limited by maximum safe operating ram pressure or buckling capacity of shaft, whichever is less.

U.S. Patents 5,234,287, 4,708,528, 5,123,209



156 Circle Freeway Dr.
Cincinnati, OH 45246
800-822-7437
www.MagnumPiering.com

MAGNUM® MP429U Push Pier

Up to 80 Tons Allowable Capacity in Compression

High-Strength 4.50" Diameter, 0.29" Wall, Round-Shaft Push Piers with Male-Female Slip Connectors

Description: MAGNUM® Push Pier sections couple together with male-female slip connectors. High strength steel offers increased buckling resistance compared to others. A friction reduction collar can be added to the pile to increase penetration depth. Structural capacities are developed according to AISC 360 and ICC-AC517 considering buckling of 5 ft unbraced length after 75 years of corrosion in moderate to high aggressive soils for various material coatings. Custom lengths are available upon request. See MAGNUM® Technical Manual for additional information.



Steel Specifications			
Shaft	HSS 4.50" x 0.29" Wall ASTM A252, Fy = 80 ksi, or Equivalent		
Coating	Hot-Dip Galvanized (G) or Bare Steel (NG)		
Section Properties	New	Galvanized (G)	Bare Steel (NG)
I	8.54	8.35	7.06
A _g	3.84	3.76	3.18
S	3.79	3.72	3.17
Structural Capacity In Compression*			
Ultimate Capacity	136 Tons	133 Tons	113 Tons
Allowable Capacity		80 Tons	67 Tons
Capacity From Load Test**			
Maximum Test Load	122 Tons		
Allowable Capacity	82 Tons		
Standard Ram	8.30 sq. in Piston Area, 7,500 Maximum P.S.I.		

* Push piers shall be installed to appropriate depth into suitable bearing stratum as determined by geotechnical engineer or local practice. For tension capacity, push pier sections must be welded together or a reinforcing steel bar and grout must be placed in the pile.

** Push pier geotechnical capacity is determined by load test using MAGNUM® Installation Rams or Lifting Kit. All push piers shall be load tested to 1.5 times the desired working load. Test load is limited by maximum safe operating ram pressure or buckling capacity of shaft, whichever is less.

U.S. Patents 5,234,287, 4,708,528, 5,123,209

MAGNUM®
P I E R I N G
designed to support

156 Circle Freeway Dr.
Cincinnati, OH 45246
800-822-7437
www.MagnumPiering.com

MAGNUM® MP434U Push Pier

Up to 92 Tons Allowable Capacity in Compression

High-Strength 4.50" Diameter, 0.337" Wall, Round-Shaft Push Piers with Male-Female Slip Connectors

Description: MAGNUM® Push Pier sections couple together with male-female slip connectors. High strength steel offers increased buckling resistance compared to others. A friction reduction collar can be added to the pile to increase penetration depth. Structural capacities are developed according to AISC 360 and ICC-AC517 considering buckling of 5 ft unbraced length after 75 years of corrosion in moderate to high aggressive soils for various material coatings. Custom lengths are available upon request. See MAGNUM® Technical Manual for additional information.



Steel Specifications			
Shaft	HSS 4.50" x 0.337" Wall ASTM A252, Fy = 80 ksi, or Equivalent		
Coating	Hot-Dip Galvanized (G) or Bare Steel (NG)		
Section Properties	New	Galvanized (G)	Bare Steel (NG)
I	9.61	9.43	8.18
A _g	4.41	4.33	3.76
S	4.27	4.2	3.67
Structural Capacity In Compression*			
Ultimate Capacity	156 Tons	153 Tons	133 Tons
Allowable Capacity		92 Tons	79 Tons
Capacity From Load Test**			
Maximum Test Load	140 Tons		
Allowable Capacity	94 Tons		
Standard Ram	8.30 sq. in Piston Area, 7,500 Maximum P.S.I.		

* Push piers shall be installed to appropriate depth into suitable bearing stratum as determined by geotechnical engineer or local practice. For tension capacity, push pier sections must be welded together or a reinforcing steel bar and grout must be placed in the pile.

** Push pier geotechnical capacity is determined by load test using MAGNUM® Installation Rams or Lifting Kit. All push piers shall be load tested to 1.5 times the desired working load. Test load is limited by maximum safe operating ram pressure or buckling capacity of shaft, whichever is less.



U.S. Patents 5,234,287, 4,708,528, 5,123,209



156 Circle Freeway Dr.
Cincinnati, OH 45246
800-822-7437
www.MagnumPiering.com

Jacked Pile Coupling Specifications

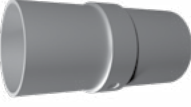
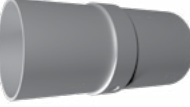
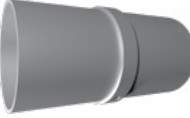
System Ratings & Specifications

Product	Coupling O.D. (in)**	Length (in)	Coating	Ultimate Capacity (tons)	Allowable Capacity (tons)	Schematic
MJP55C	4.98	11	*G, NG, EP	100	50	
MJP70C	6.5	13	*G, NG, EP	100	50	
MJP86C	8.0	19.25	*G, NG, EP	100	75	
MJP100C	10	23.5	*G, NG, EP	150	75	
MJP55-70T	6.5	11.1	*G, NG, EP	100	50	

Notes:

*G = Hot-Dip Zinc Galvanized per ASTM A123/A153, NG = Bare Steel, EP = Epoxy Powder Coated per ICC-ESAC228

**Coordinate with I.D. of pile sections.

All MAGNUM® Push Pier products are manufactured using ASTM A513 Grade 65 ksi minimum yield strength structural tubing. As Magnum is committed to testing and improving products, these specifications are subject to change. Additional product specifications are available at www.magnumpiering.com and upon request.

Steel Pile Caps

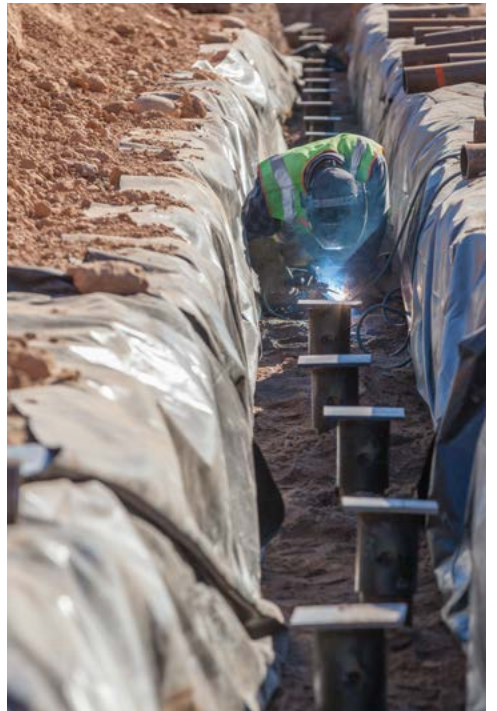

Tie-Back Cap Number Specification Legend

Example

The MAGNUM® Piering Tie-Back Cap product number below **MHC1080-31024BR2G** is for a threaded tie-back cap with 24" long, #10 Gr. 75 thread bar. The collar tube fits a 3.0" diameter shaft with reinforced double bolted connection. The surface preparation is Galvanized.

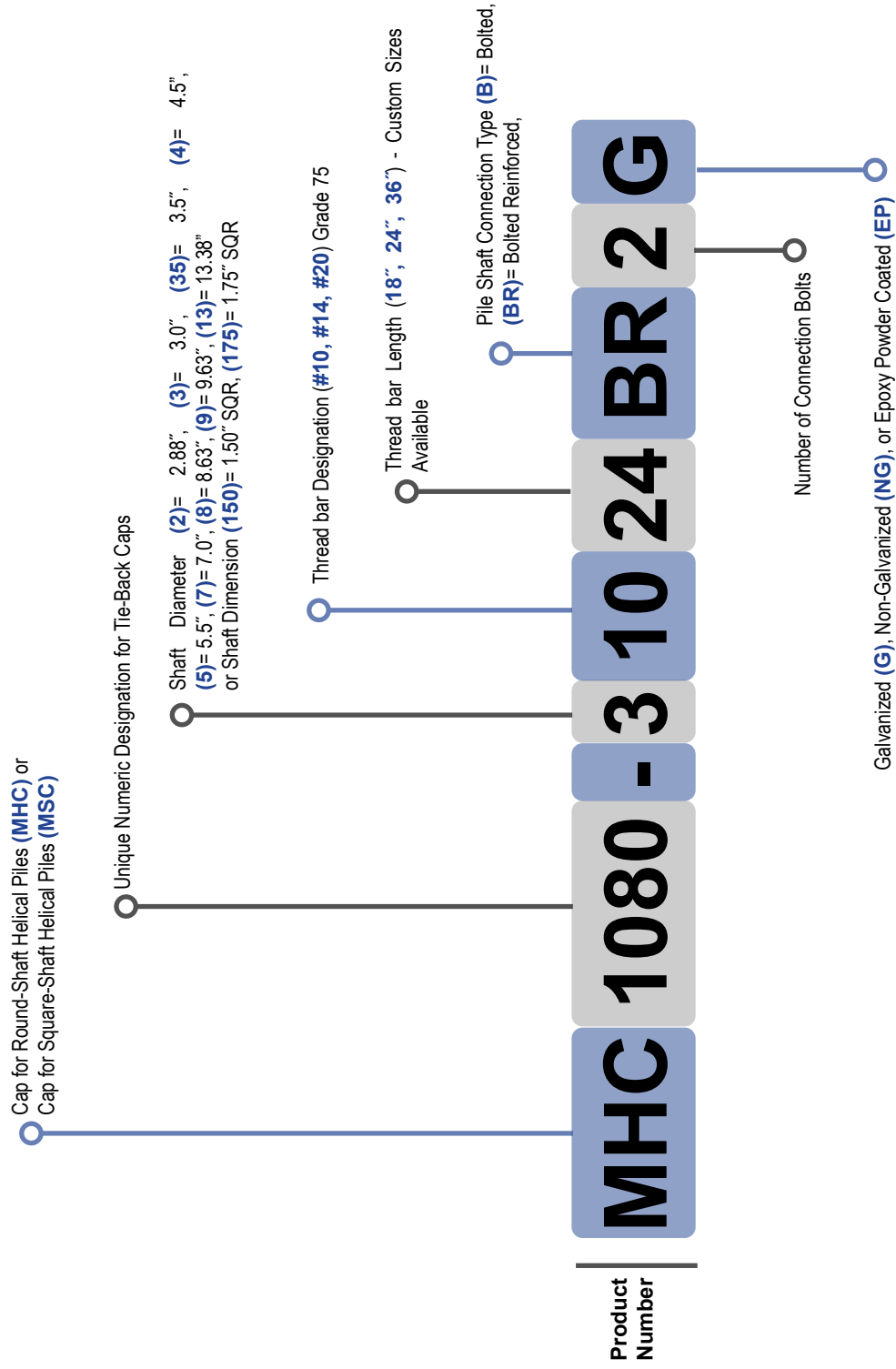

Bearing Plate Cap Number Specification Legend

Example

The MAGNUM® Bearing Plate Cap product number below **MHC1300-4L99B2NG** is for a Cap with 4.63" inside diameter collar tube with a 9" long by 9" wide plate with 0.5" thickness, a bolted connection with 2 bolts, and the surface preparation is Non-Galvanized.

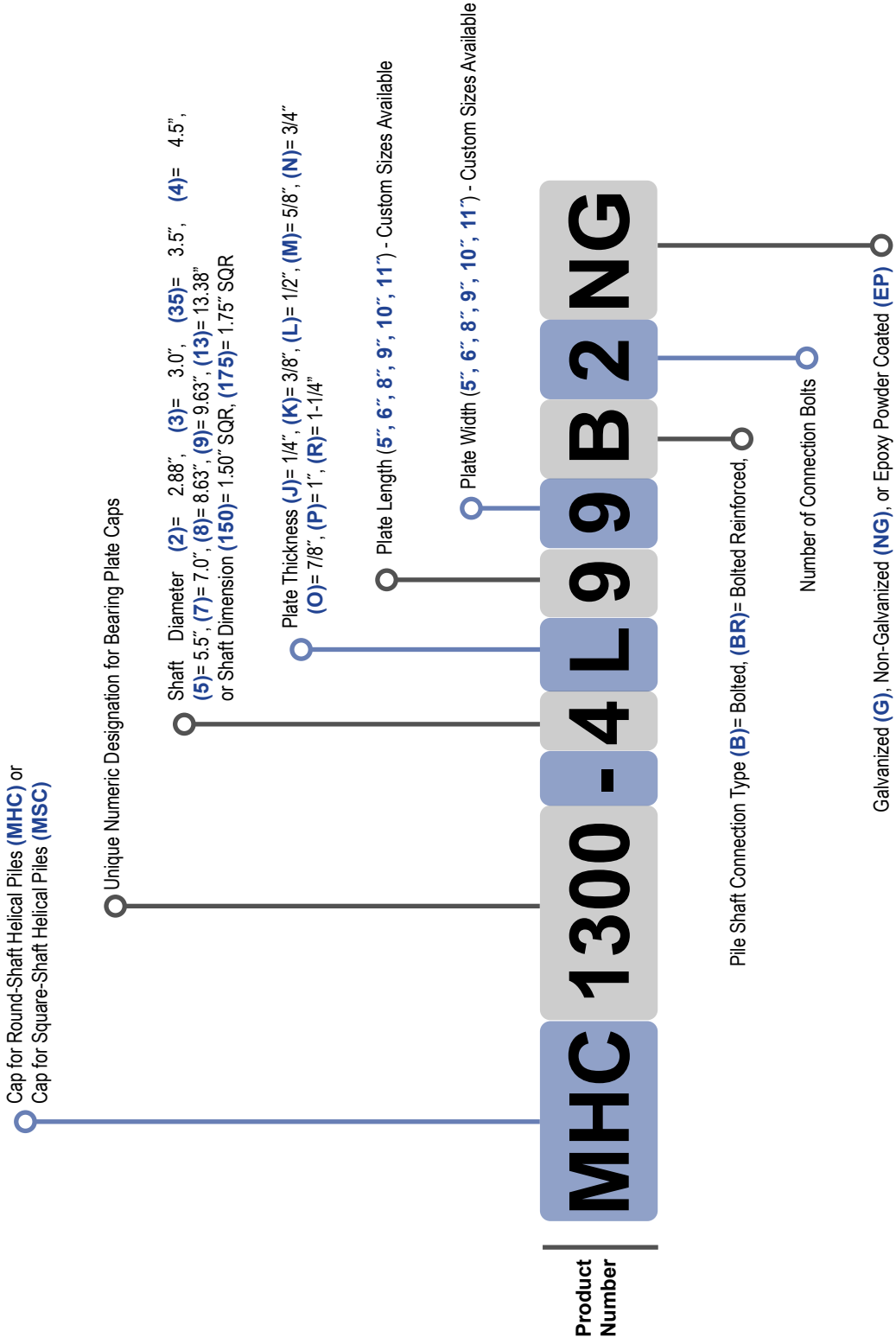

Rebar Cap Number Specification Legend

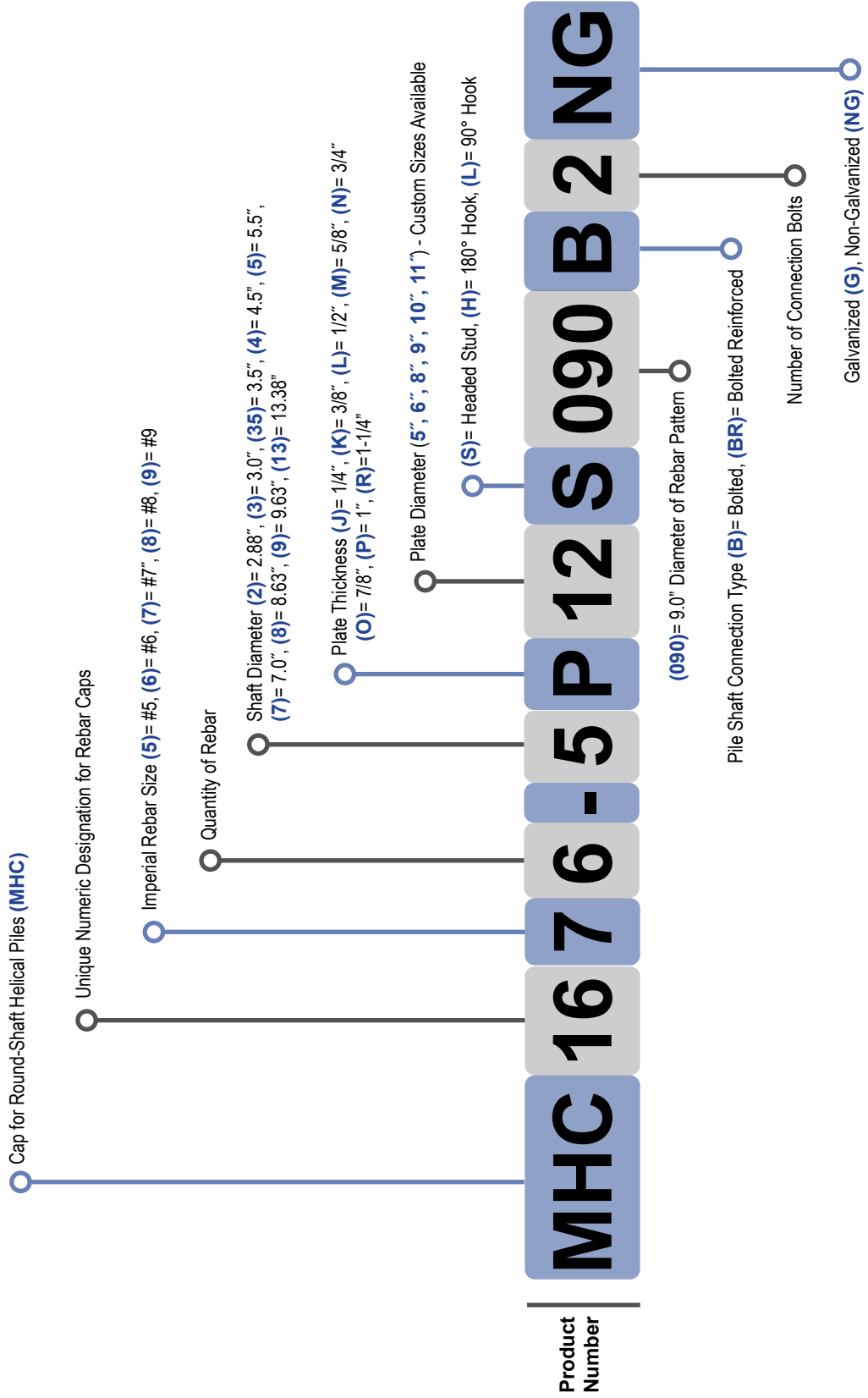

Example

The MAGNUM® Rebar Cap product number below **MHC1676-5P12S090B2NG** is for a cap with 5.63" inside diameter collar tube with a 12" round plate with 1" thickness, with six, #7 headed rebar studs on a 9.0" circle pattern, a double bolted connection, and the surface preparation is Non-Galvanized.

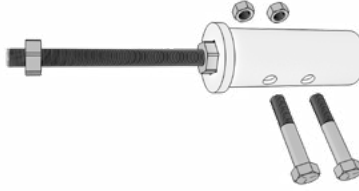
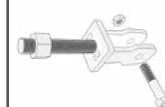

Helical Pile Cap Specifications

System Ratings & Specifications

Helical Pile Caps	Name	Helical Pile Dia. (in)	No. Bolts / Thru Holes	Bolt Dia. (in)	Structural Capacity*		Description	Coating	Schematic
					Ultimate (tons) Comp / Tens	Allowable (tons) Comp / Tens			
MSC1080-150824B	Tie-Back Cap	SQ. 1.5	1	7/8	NA / 35	NA / 17.5	(1) 24" #8, Gr. 75 Thread Bar with (1) #8 Nut	NG, G, EP	
MSC1080-1751024B	Tie-Back Cap	SQ. 1.75	1	1	NA / 55	NA / 27.5	(1) 24" #10, Gr. 75 Thread Bar with 2.37-inch I.D. Collar and (1) #8 Nut	NG, G, EP	
MHC1080-3008HB112	Tie-Back Cap	3	1	7/8	NA / 25	NA / 12.5	(1) 12" #8, Gr. 75 Thread Bar with (1) #8 Nut and 3.13-inch I.D. Collar	NG, G, EP	
MHC1080-31024B	Tie-Back Cap	3	1	7/8	NA / 32	NA / 16	(1) 24" #10, Gr. 75 Thread Bar with (1) #10 Nut	NG, G, EP	
MHC1080-31024BR2	Tie-Back Cap	3	2	1	NA / 50	NA / 25	(1) 24" #10, Gr. 75 Thread Bar with (1) #10 Nut	NG, G, EP	
MHC1080-3508B	Tie-Back Cap	3.5	1	1	NA / 34	NA / 17	(1) 24" #8, Gr. 75 Thread Bar with (1) #8 Nut	NG, G, EP	
MHC1080-3514B	Tie-Back Cap	3.5	1	1	NA / 49	NA / 27	(1) 24" #14, Gr. 75 Thread Bar with (1) #14 Nut	NG, G, EP	
MHC1080-41024B	Tie-Back Cap	4	2	1-1/4	NA / 63	NA / 31	(1) 24" #10, Gr. 75 Thread Bar with (1) #10 Nut	NG, G, EP	
MHC1080-41424B	Tie-Back Cap	4	2	1-1/4	NA / 97	NA / 48	(1) 24" #14, Gr. 75 Thread Bar with (1) #14 Nut	NG, G, EP	
MHC1080-52024B	Tie-Back Cap	5.5	3	1-1/2	NA / 196	NA / 98	(1) 24" #20, Gr. 75 Thread Bar with #20 Nut	NG, G, EP	
MHC1080-6020B2	Tie-Back Cap	6	3	1-1/2	NA / 191	NA / 95	(1) 24" #20, Gr. 75 Thread Bar with #20 Nut	NG, G, EP	
MSC1084-150B	Tie-Back Cap	SQ. 1.5	1	7/8	NA / 35	NA / 20	Clevis Side Plates and End Plate with 1.125" Hole for #8 Thread Bar	NG, G, EP	
MSC1084-175B	Tie-Back Cap	SQ. 1.75	1	1	NA / 45	NA / 26.7	Clevis Side Plates and End Plate with 1.25" Hole for #9 Thread Bar	NG, G, EP	
MSC1172-175B1	Tie-Back Cap	SQ. 1.75	1	1	NA / 39	NA / 22	4" x 6" x 1-1/4" Tension Lug	NG, G, EP	
MHC1172-3BR2	Tie-Back Cap	3	2	1	NA / 45	NA / 25	4" x 5-1/2" x 1-1/4" Tension Lug	NG, G, EP	
MHC1172-4B2	Tie-Back Cap	4	2	1-1/4	NA / 65	NA / 36	4-3/4" x 6" x 1-1/2" Tension Lug	NG, G, EP	
MHC1172-5B2	Tie-Back Cap	5.5	2	1-1/2	NA / 116	NA / 60	6" x 8" x 2" Tension Lug	NG, G, EP	
MHC1000-3B	Grade Beam Cap	3	1	7/8	50 / 32	25 / 16	(2) #7, Gr. A706 Reinforcing Steel Bars Horizontal	NG, G, EP	
MHC1000-3BR2	Grade Beam Cap	3	2	1	50 / 50	25 / 25	(2) #7, Gr. A706 Reinforcing Steel Bars Horizontal	NG, G, EP	

Helical Pile Cap Specifications

System Ratings & Specifications

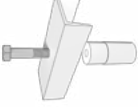
Helical Pile Caps	Name	Helical Pile Dia. (In)	No. Bolts / Thru Holes	Bolt Dia. (In)	Structural Capacity*		Description	Coating	Schematic
					Ultimate (tons) Comp / Tens	Allowable (tons) Comp / Tens			
MSC1040-150B	Bond Bar Cap	SQ. 1.5	1	7/8"	35 / 35	17.5 / 17.5	(2) #7, Gr. A706 Reinforcing Steel Bars Vertical	NG, G, EP	
MSC1040-175B	Bond Bar Cap	SQ. 1.75	1	1	55 / 55	27.5 / 27.5	(3) #7, Gr. A706 Reinforcing Steel Bars Vertical	NG, G, EP	
MHC1040-3B	Bond Bar Cap	3	1	7/8	32 / 32	16 / 16	(2) #7, Gr. A706 Reinforcing Steel Bars Vertical	NG, G, EP	
MHC1040-3BR2	Bond Bar Cap	3	2	1	50 / 50	25 / 25	(3) #7, Gr. A706 Reinforcing Steel Bars Vertical	NG, G, EP	
MHC1040-4B	Bond Bar Cap	4	2	1-1/4	72 / 72	36 / 36	(4) #7, Gr. A706 Reinforcing Steel Bars Vertical	NG, G, EP	
MHC1100-316	Slab Lift Cap	3	Direct	Bearing	28	14	16" Channel and Lifting Bolt Assembly	NG, G, EP	
MHC1100-336	Slab Lift Cap	3	Direct	Bearing	28	14	36" Channel with Lifting Bolt Assembly	NG, G, EP	
MSC1300-150M55B	Bearing Plate Cap	SQ. 1.5	1	7/8	32 / 28	16 / 14	5" x 5" x 5/8" Bearing Plate	NG, G, EP	
MSC1300-175O6655B	Bearing Plate Cap	SQ. 1.75	1	1	52 / 36	26 / 18	6-1/2" x 6-1/2" x 7/8" Bearing Plate	NG, G, EP	
MHC1300-2K55B1	Bearing Plate Cap	2.875	1	3/4	25 / 25	13 / 13	5" x 5" x 3/8" Bearing Plate	NG, G, EP	
MHC1300-2M66B2	Bearing Plate Cap	2.875	2	3/4	54 / 54	27 / 27	6" x 6" x 5/8" Bearing Plate	NG, G, EP	
MHC1300-3K55B	Bearing Plate Cap	3	1	7/8	32 / 32	16 / 16	5" x 5" x 3/8" Bearing Plate	NG, G, EP	
MHC1300-3M665BR2	Bearing Plate Cap	3	2	1	50 / 50	25 / 25	6-1/2" x 6-1/2" x 5/8" Bearing Plate	NG, G, EP	
MHC1300-3M66BR1	Bearing Plate Cap	3	1	1	50 / 36	25 / 18	6" x 6" x 5/8" Bearing Plate	NG, G, EP	
MHC1300-35L66BR1	Bearing Plate Cap	3.5	1	1	28 / 22	14 / 11	6" x 6" x 1/2" Bearing Plate	NG, G, EP	
MHC1300-35M66B1	Bearing Plate Cap	3.5	1	1	66 / 48	33 / 24	6" x 6" x 5/8" Bearing Plate	NG, G, EP	
MHC1300-4N88B1	Bearing Plate Cap	4	1	1-1/4	77 / 46	38.5 / 23	8" x 8" x 3/4" Bearing Plate	NG, G, EP	
MHC1300-4N88B2	Bearing Plate Cap	4	2	1-1/4	92 / 92	46 / 46	8" x 8" x 3/4" Bearing Plate	NG, G, EP	
MHC1300-5N18B1	Bearing Plate Cap	5.5	1	1-1/2	32 / 32	16 / 16	18" Ø x 3/4" Bearing Plate	NG, G, EP	
MHC1300-5O99B1	Bearing Plate Cap	5.5	1	1-1/2	136 / 78	68 / 39	9" x 9" x 7/8" Bearing Plate	NG, G, EP	
MHC1300-5O99B3	Bearing Plate Cap	5.5	3	1-1/2	140 / 140	70 / 70	9" x 9" x 7/8" Bearing Plate	NG, G, EP	
MHC1300-5R111B1	Bearing Plate Cap	5.5	1	1-1/2	232 / 58	116 / 29	11" x 11" x 1-1/4" Bearing Plate	NG, G, EP	
MHC1300-5R111B3	Bearing Plate Cap	5.5	3	1-1/2	232 / 120	116 / 60	11" x 11" x 1-1/4" Bearing Plate	NG, G, EP	

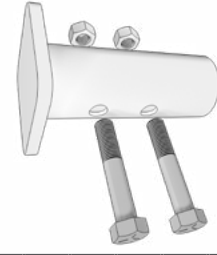



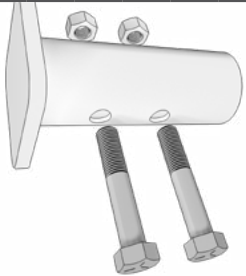
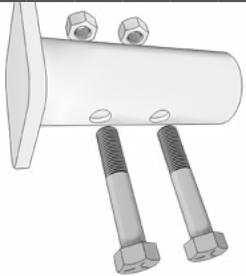
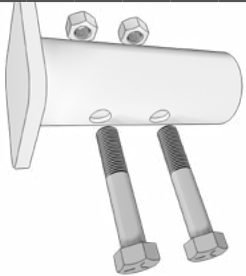
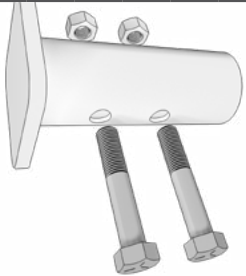
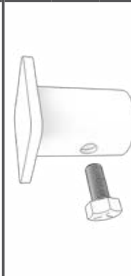
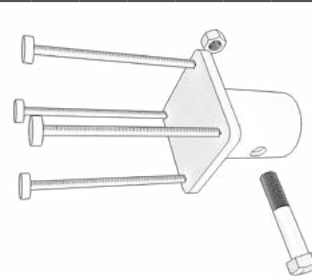
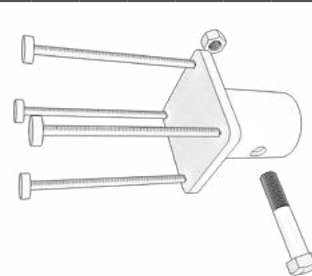
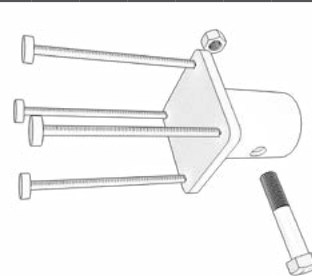

Helical Pile Cap Specifications

System Ratings & Specifications

Helical Pile Caps	Name	Helical Pile Dia.(in)	No. Bolts / Thru Holes	Bolt Dia. (in)	Structural Capacity*		Description	Coating	Schematic
					Ultimate (tons) Comp / Tens	Allowable (tons) Comp / Tens			
MHC1300-601111B1	Bearing Plate Cap	6	1	1-1/2	116 / 74	58 / 37	11" x 11" x 7/8" Bearing Plate	NG, G, EP	
MHC1300-6P1818B2	Bearing Plate Cap	6	3	1-1/2	80 / 80	40 / 40	18" x 18" x 1" Bearing Plate	NG, G, EP	
MHC1300-701111B1	Bearing Plate Cap	7	1	1-1/2	164 / 78	82 / 39	11" x 11" x 7/8" Bearing Plate	NG, G, EP	
MHC1300-8N1212B2	Bearing Plate Cap	8.625	1	1-1/2	160 / 60	80 / 30	12" x 12" x 3/4" Bearing Plate	NG, G, EP	
MHC1300-9O1313B1	Bearing Plate Cap	9.625	1	1-1/2	280 / 90	140 / 45	13" x 13" x 7/8" Bearing Plate	NG, G, EP	
MHC1300-9O1313B3	Bearing Plate Cap	9.625	3	1-1/2	280 / 214	140 / 107	13" x 13" x 7/8" Bearing Plate	NG, G, EP	
MHC1300-12N25B2	Bearing Plate Cap	12	2	1-1/2	54 / 54	27 / 27	25" Ø X 3/4" Bearing Plate	NG, G, EP	
MHC1300-13O1616B1	Bearing Plate Cap	13.375	1	1-1/2	199 / 70	99.5 / 35	16" x 16" x 7/8" Bearing Plate	NG, G, EP	
MHC1300-13O1616B3	Bearing Plate Cap	13.375	3	1-1/2	200 / 200	100 / 100	16" x 16" x 7/8" Bearing Plate	NG, G, EP	
MHC1300-16P1818B2	Bearing Plate Cap	16	2	1-1/2	186 / 186	93 / 93	18" x 18" x 1" Bearing Plate	NG, G, EP	
MHC1300-18O2424B3	Bearing Plate Cap	18.625	3	1-1/2	238 / 238	119 / 119	24" x 24" x 7/8" Bearing Plate	NG, G, EP	
MHC2300-2K55T1	Clamp Bearing Plate Cap	2.875	1	3/4	32 / 1	16 / 0.5	5" x 5" x 3/8" Bearing Plate	NG, G, EP	
MHC2300-3M66T1	Clamp Bearing Plate Cap	3	1	3/4	46 / 1	23 / 0.5	6" x 6" x 5/8" Bearing Plate	NG, G, EP	
MHC2300-4N88T1	Clamp Bearing Plate Cap	4.5	1	7/8	110 / 2	55 / 1	8" x 8" x 3/4" Bearing Plate	NG, G, EP	
MHC1654-3M66S040BR1	Rebar Plate Cap	3	1	1	59 / 44	30 / 22	6" x 6" x 5/8" Bearing Plate	NG, G	
MCH1658-4P10S080B2	Rebar Plate Cap	4.5	2	1-1/4	108 / 88	54 / 44	10"Ø x 1" Bearing Plate	NG, G	
MHC1688-5P12S105B1	Rebar Plate Cap	5.5	1	1-1/2	151 / 79	76 / 40	12"Ø x 1" Bearing Plate	NG, G	
MHC1688-7R15S130B3	Rebar Plate Cap	7	3	1-1/2	224 / 226	112 / 113	15"Ø x 1-1/4" Bearing Plate	NG, G	
MHC1678-9P16S132B3	Rebar Plate Cap	9.625	3	1-1/2	220 / 173	110 / 87	16"Ø x 1" Bearing Plate	NG, G	
MHC16912-10X24S215B3	Rebar Plate Cap	10.75	3	2	524 / 431	262 / 215	24"Ø x 2" Bearing Plate	NG, G	
MHC1688-12R20S180B3	Rebar Plate Cap	12.75	3	1-1/2	381 / 226	190 / 113	20"Ø x 1-1/4" Bearing Plate	NG, G	
MHC1688-13T24S210B3	Rebar Plate Cap	13.375	3	1-1/2	225 / 226	112 / 113	24"Ø x 1-1/2" Bearing Plate	NG, G	
MHC1698-16T24S215B3	Rebar Plate Cap	16	3	1-1/2	407 / 282	204 / 141	24"Ø x 1-1/2" Bearing Plate	NG, G	
MHC16912-18R25S226B3	Rebar Plate Cap	18.625	3	1-1/2	569 / 282	284 / 141	25"Ø x 1-1/4" Bearing Plate	NG, G	

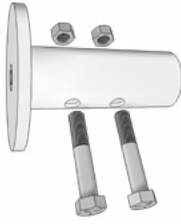
Helical Pile Cap Specifications

System Ratings & Specifications

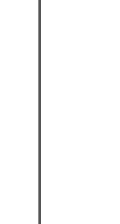
Helical Pile Caps	Name	Helical Pile Dia. (in)	No. Bolts / Thru Holes	Bolt Dia. (in)	Structural Capacity*		Description	Coating	Schematic
					Ultimate (tons) / Tens	Allowable (tons) Comp / Tens			
MHC1082-3BR1	Adjustable Plate Cap	3	1	1	35 / 35	17 / 17	12"Ø x 1/2" Bearing Plate	NG, G, EP	
MHC1082-4B1	Adjustable Plate Cap	4	1	1-1/4	40 / 40	20 / 20	14"Ø x 5/8" Bearing Plate	NG, G, EP	
MHC1082-5O16B1	Adjustable Plate Cap	5.5	1	1-1/2	55 / 42	27.5 / 21	16"Ø x 7/8" Bearing Plate	NG, G, EP	
MHC1082-5B1	Adjustable Plate Cap	5.5	1	1-1/2	42 / 42	21 / 21	16"Ø x 7/8" Bearing Plate	NG, G, EP	
MHC1304-3N12BR2	Circular Plate Cap	3	2	1	38 / 46	19 / 23	12"Ø x 3/4" Bearing Plate	NG, G, EP	
MHC1304-4O12B2	Circular Plate Cap	4	2	1-1/4	91 / 66	46 / 33	12"Ø x 7/8" Bearing Plate	NG, G, EP	
MHC1304-5O12B2	Circular Plate Cap	5.5	2	1-1/2	148 / 66	74 / 33	12"Ø x 7/8" Bearing Plate	NG, G, EP	
MHC1305-3N11BR1	Circular Plate Cap	3	1	1	50 / 36	25 / 18	12"Ø x 3/4" Bearing Plate	NG, G, EP	
MHC1350-5N6135B1	Gusseted Cap	5.5	1	1-1/2	195 / 65	98 / 33	6" x 13-1/2" x 3/4" Bearing Plate	NG, G, EP	
MHC1350-5N6135B3	Gusseted Cap	5.5	3	1-1/2	195 / 165	98 / 83	6" x 13-1/2" x 3/4" Bearing Plate	NG, G, EP	
MHC1350-9P24B3	Gusseted Cap	9.625	3	1-1/2	224 / 224	112 / 112	24" x 24" x 1" Bearing Plate	NG, G, EP	
MHC1415-3O1010B	Tilted Plate Cap	3	1	7/8	32 / 32	16 / 16	10" x 10" x 7/8" Bearing Plate Tilted 15°	NG, G, EP	
MHC1420-3N11BR1	Tilted Plate Cap	3	1	1	50 / 36	25 / 18	11"Ø x 3/4" Bearing Plate Tilted 20°	NG, G, EP	
MHC1420-3N1212BR	Tilted Plate Cap	3	2	1	50 / 50	25 / 25	12" x 12" x 3/4" Bearing Plate Tilted 20°	NG, G, EP	
MHC1420-5O12B2	Tilted Plate Cap	5.5	2	1-1/2	92 / 66	46 / 33	12"Ø x 7/8" Bearing Plate Tilted 30°	NG, G, EP	
MHC1430-4O12B2	Tilted Plate Cap	4	2	1-1/4	91 / 66	46 / 33	12"Ø x 7/8" Bearing Plate Tilted 30°	NG, G, EP	

Helical Pile Cap Specifications

System Ratings & Specifications

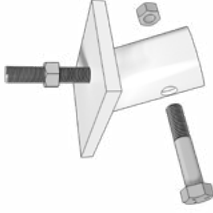
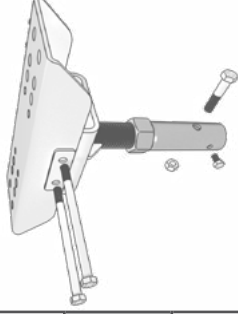
Helical Pile Caps	Name	Helical Pile Dia. (in)	No. Bolts / Thru Holes	Bolt Dia. (In)	Structural Capacity*		Description	Coating	Schematic
					Ultimate (tons) / Tens	Allowable (tons) Comp / Tens			
MHC1530-3N68BR1	Panel Brace Cap	3	1	7/8	32 / 24	16 / 12	6" x 8" x 3/4" Plate Tilted 30° with 3/4" Stud	NG, G, EP	
MHC1545-3N68B	Panel Brace Cap	3	1	7/8	32 / 32	16 / 16	6" x 8" x 3/4" Plate Tilted 45° with 3/4" Stud	NG, G, EP	
MHC1087-3BR1	Pipe Support Cap	3	1	1-1/4	6	2.5	7" x 25" x 1/2" Bearing Plate	NG, G, EP	
MHC1088-3BR1	Pipe Support Cap	3	1	1-1/4	6	2.5	7" x 23" x 1/2" Bearing Plate	NG, G, EP	
MHC1091-3BR1	Pipe Support Cap	3	1	1	6	2.5	8" x 25" x 5/8" Formed Channel Bearing Plate	NG, G, EP	
MHC1092-3BR1	Pipe Support Cap	3	1	1	6	2.5	8" x 25" x 5/8" Formed Channel Bearing Plate	NG, G, EP	
MHC1093-3BR1	Pipe Support Cap	3	1	1	6	2.5	8" x 25" x 5/8" Formed Channel Bearing Plate	NG, G, EP	

NOTES: Structural capacity of cap and pile system may be limited by the capacity of the pile and the structure to which the cap is connected. See MAGNUM® Helical Pile Specifications for more information. Capacity of the structure shall be determined by an engineer. As an alternate to drilling and bolting, pile cap may be attached using plug welds located at the collar tube bolt holes. Remove coatings from surfaces prior to welding. See MAGNUM® technical bulletin TB004.0 for more information.

Surface Coating: G = Hot-Dip Zinc Galvanized per ASTM A123/A153, NG = Bare Steel, EP = Epoxy Powder Coated per ICC-ES AC208, P = Magnum Blue Paint.

As MAGNUM® is committed to testing and improving products, these specifications are subject to change. Additional product specifications available at www.magnumpiering.com and in the MAGNUM® Helical Pile Engineering Manual available upon request.

MAGNUM® MSC1080-150824B Tie-Back Cap

Allowable Capacity - 17.5 Tons Tension

(1) 24" #8, Gr. 75 Thread Bar with (1) #8 Nut & 2-Inch I.D. Collar

Fits MS150 Helical Piers

Description: MAGNUM® Tie-Back Caps consist of a collar tube with bolt hole for connection to MAGNUM® helical piles and a thread bar & nut for attachment to various earth retention structures and foundations. The tie-back caps are manufactured in the USA according to our ISO 9001 approved quality program. Structural capacities are developed according to AISC 360 considering an average design life of 75 years for bare steel in most soil conditions. Hot-dip galvanizing is available upon request. Design and detailing of the structure to which the helical tie-back cap is attached varies by project and is the responsibility of registered design professional including but not limited to waler size, bearing plate or wall facing (if any), and concrete cover as applicable.

Specifications	
Collar Tube	0.25" x 2" I.D. ASTM A513, Fy = 65 ksi or Better
End Effector	(1) #8 x 24" Gr. 75 Thread Bar & (1) #8 Nut - Plates & Washers Sold Separately
Pile Connection	(1) 7/8" SAE J429 Grade 5 Zinc Coated to ASTM B695/F1941
Coating	Galvanized per ASTM A153/A123 (G), Bare Steel (NG), or Epoxy Coated per ICC-ES AC228 (EP)
Compatibility	MS150B
Capacity	
Ultimate Compression/Tension	NA / 35 Tons
Allowable Compression/Tension	NA / 17.5 Tons

Notes: Cap capacity is developed using the ASD design method and considers strength of collar, end effector, and pile connection. Capacity may be limited by the helical pile itself, bearing/pullout capacity of soil, or strength of the structure to which the cap is attached.



Installation Notes: After installation of a MAGNUM® Helical Anchor or Pile to the correct depth, torque, and capacity, begin by cutting-off the pile shaft at the proper elevation. Drill (1) 15/16" hole using the MAGNUM® drill template. Place the pile cap over the shaft and secure with (1) 7/8" bolt. Snug tighten nuts. Snug tighten or post-tension thread bar nut against bearing plate as required for the project.



Bearing Plate & Washers Sold Separately

MAGNUM®
P I E R I N G
designed to support

156 Circle Freeway Dr.
Cincinnati, OH 45246
800-822-7437
www.MagnumPiering.com

MAGNUM® MSC1080-1751024B Tie-Back Cap

Allowable Capacity - 27.5 Tons Tension

(1) 24" #10, Gr. 75 Thread Bar with (1) #10 Nut & 2.37-Inch I.D. Collar
Fits MS175 Helical Piers

Description: MAGNUM® Tie-Back Caps consist of a collar tube with bolt hole for connection to MAGNUM® helical piles and a thread bar & nut for attachment to various earth retention structures and foundations. The tie-back caps are manufactured in the USA according to our ISO 9001 approved quality program. Structural capacities are developed according to AISC 360 considering an average design life of 75 years for bare steel in most soil conditions. Hot-dip galvanizing is available upon request. Design and detailing of the structure to which the helical tie-back cap is attached varies by project and is the responsibility of registered design professional including but not limited to water size, bearing plate or wall facing (if any), and concrete cover as applicable.

Specifications	
Collar Tube	0.25" x 2.375" I.D. ASTM A513, Fy = 65 ksi or Better
End Effector	(1) #10 x 24" Gr. 75 Thread Bar & (1) #10 Nut [Bearing Plate & Washers Sold Separately]
Pile Connection	(1) 1" SAE J429 Grade 8 Zinc Coated to ASTM B695/F1941
Coating	Galvanized per ASTM A153/A123 (G), Bare Steel (NG), or Epoxy Coated per ICC-ES AC228 (EP)
Compatibility	MS175B
Capacity	
Ultimate Compression/Tension	NA / 55 Tons
Allowable Compression/Tension	NA / 27.5 Tons



Notes: Cap capacity is developed using the ASD design method and considers strength of collar, end effector, and pile connection. Capacity may be limited by the helical pile itself, bearing/pullout capacity of soil, or strength of the structure to which the cap is attached.

Installation Notes: After installation of a MAGNUM® Helical Anchor or Pile to the correct depth, torque, and capacity, begin by cutting-off the pile shaft at the proper elevation. Drill (1) 1-1/16" hole using the MAGNUM® drill template. Place the pile cap over the shaft and secure with (1) 1" bolt. Snug tighten nuts. Snug tighten or post-tension thread bar nut against bearing plate as required for the project.



Bearing Plate & Washers Sold Separately



156 Circle Freeway Dr.
Cincinnati, OH 45246
800-822-7437
www.MagnumPiering.com

MAGNUM® MHC1080-3008HB112 Tie-Back Cap

Allowable Capacity - 12.5 Tons Tension

(1) 12" #8, Gr. 75 Thread Bar with (1) #8 Nut & 3.13-Inch I.D. Collar
Fits MH313B, MH313BR & MH325B Helical Piles

Description: MAGNUM® Tie-Back Caps consist of a collar tube with bolt hole for connection to MAGNUM® helical piles and a thread bar & nut for attachment to various earth retention structures and foundations. The tie-back caps are manufactured in the USA according to our ISO 9001 approved quality program. Structural capacities are developed according to AISC 360 considering an average design life of 75 years for bare steel in most soil conditions. Hot-dip galvanizing is available upon request. Design and detailing of the structure to which the helical tie-back cap is attached varies by project and is the responsibility of registered design professional including but not limited to waler size, bearing plate or wall facing (if any), and concrete cover as applicable.

Specifications	
Collar Tube	0.25" x 3.13" I.D. ASTM A513, Fy = 65 ksi or Better
End Effector	(1) #8 x 12" Gr. 75 Thread Bar & (1) #8 Nut - Plates & Washers Sold Separately
Pile Connection	(1) 7/8" SAE J429 Grade 5 Zinc Coated to ASTM B695/F1941
Coating	Galvanized per ASTM A153/A123 (G), Bare Steel (NG), or Epoxy Coated per ICC-ES AC228 (EP)
Compatibility	MH313B, MH313BR, MH325B
Capacity	
Ultimate Compression/Tension	NA / 25 Tons
Allowable Compression/Tension	NA / 12.5 Tons
Installation Torque Rating	13,200 ft*lb

Notes: Cap capacity is developed using the ASD design method and considers strength of collar, end effector, and pile connection. Capacity may be limited by the helical pile itself, bearing/pullout capacity of soil, or strength of the structure to which the cap is attached.

Bearing Plate & Washers Sold Separately

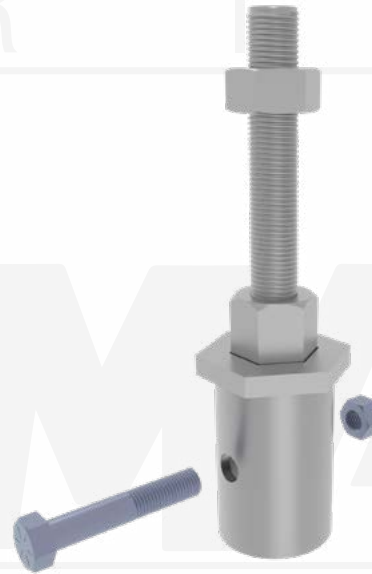

Installation Notes: After installation of a MAGNUM® Helical pile and any extensions, place the cap on the last segment and secure with (1) 7/8" bolt, snug tighten nut. Omit the thread bar, and continue installation until the correct depth and torque is achieved. Install the thread bar and bearing plate, walers or brackets as applicable. Snug tighten or post-tension thread bar nut against bearing plate as required for the project.



MAGNUM®
P I E R I N G
designed to support

156 Circle Freeway Dr.
Cincinnati, OH 45246
800-822-7437
www.MagnumPiering.com

MAGNUM® MHC1080-31024B Tie-Back Cap

Allowable Capacity - 16 Tons Tension

(1) 24" #10, Gr. 75 Thread Bar with (1) #10 Nut & 3.13-Inch I.D. Collar
 Fits MH313B, MH313BR & MH325B Helical Piles

Description: MAGNUM® Tie-Back Caps consist of a collar tube with bolt hole for connection to MAGNUM® helical piles and a thread bar & nut for attachment to various earth retention structures and foundations. The tie-back caps are manufactured in the USA according to our ISO 9001 approved quality program. Structural capacities are developed according to AISC 360 considering an average design life of 75 years for bare steel in most soil conditions. Hot-dip galvanizing is available upon request. Design and detailing of the structure to which the helical tie-back cap is attached varies by project and is the responsibility of registered design professional including but not limited to waler size, bearing plate or wall facing (if any), and concrete cover as applicable.

Specifications	
Collar Tube	0.25" x 3.13" I.D. ASTM A513, Fy = 65 ksi or Better
End Effector	(1) #10 x 24" Gr. 75 Thread Bar & (1) #10 Nut - Plates & Washers Sold Separately
Pile Connection	(1) 7/8" SAE J429 Grade 5 Zinc Coated to ASTM B695/F1941
Coating	Galvanized per ASTM A153/A123 (G), Bare Steel (NG), or Epoxy Coated per ICC-ES AC228 (EP)
Compatibility	MH313B, MH313BR, MH325B
Capacity	
Ultimate Compression/ Tension	NA / 32 Tons
Allowable Compression/ Tension	NA / 16 Tons

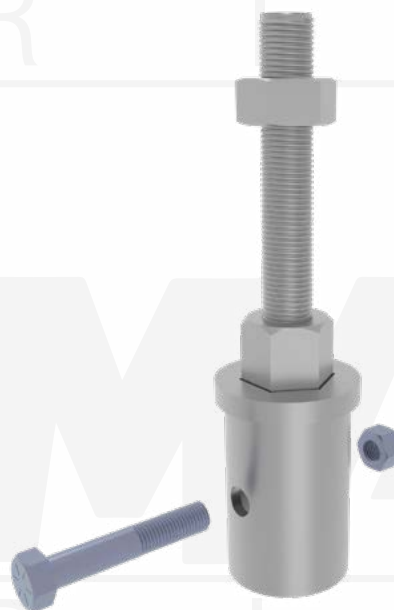

Notes: Cap capacity is developed using the ASD design method and considers strength of collar, end effector, and pile connection. Capacity may be limited by the helical pile itself, bearing/pullout capacity of soil, or strength of the structure to which the cap is attached.

Installation Notes: After installation of a MAGNUM® Helical Pile to the correct depth, torque, and capacity, begin by cutting-off the pile shaft at the proper elevation. Drill (1) 15/16" hole using the MAGNUM® drill template. Place the pile cap over the shaft and secure with (1) 7/8" bolt. Snug tighten nuts. Alternatively, drilling through pile may be omitted and plug welds may be used to secure cap to pile in place of bolts, see MAGNUM® Technical Bulletin TB004. Snug tighten or post-tension thread bar nut against bearing plate as required for the project.



Bearing Plate & Washers Sold Separately



156 Circle Freeway Dr.
 Cincinnati, OH 45246
 800-822-7437
www.MagnumPiering.com

MAGNUM® MHC1080-31024HBR2 Tie-Back Cap

Allowable Capacity - 25 Tons Tension

(1) 24" #10, Gr. 75 Thread Bar with (1) #10 Nut & 3.13-Inch I.D. Collar
Fits MH325BR(-6) Helical Piles

Description: MAGNUM® Tie-Back Caps consist of a collar tube with bolt holes for connection to MAGNUM® helical piles and a thread bar & nut for attachment to various earth retention structures and foundations. The tie-back caps are manufactured in the USA according to our ISO 9001 approved quality program. Structural capacities are developed according to AISC 360 considering an average design life of 75 years for bare steel in most soil conditions. Hot-dip galvanizing is available upon request. Design and detailing of the structure to which the helical tie-back cap is attached varies by project and is the responsibility of registered design professional including but not limited to waler size, bearing plate or wall facing (if any), and concrete cover as applicable.

Specifications	
Collar Tube	0.31" x 3.13" I.D. ASTM A513, Fy = 65 ksi or Better
End Effector	(1) #10 x 24" Gr. 75 Thread Bar & (1) #10 Nut - Plate & Washer Sold Separately
Pile Connection	(2) 1" SAE J429 Grade 8 Zinc Coated to ASTM B695/F1941
Coating	Galvanized per ASTM A153/A123 (G), Bare Steel (NG), or Epoxy Coated per ICC-ES AC228 (EP)
Compatibility	MH325BR(-6)
Capacity	
Ultimate Compression/ Tension	NA / 50 Tons
Allowable Compression/ Tension	NA / 25 Tons

Notes: Cap capacity is developed using the ASD design method and considers strength of collar, end effector, and pile connection. Capacity may be limited by the helical pile itself, bearing/pullout capacity of soil, or strength of the structure to which the cap is attached.

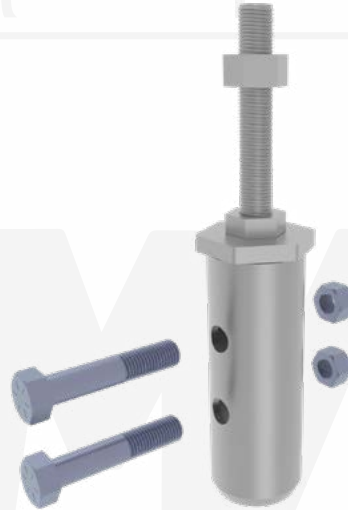

Installation Notes: After installation of a MAGNUM® Helical Pile to the correct depth, torque, and capacity, begin by cutting-off the pile shaft at the proper elevation. Drill (2) 1-1/16" holes using the MAGNUM® drill template. Place the pile cap over the shaft and secure with (2) 1" bolts. Snug tighten nuts. Alternatively, drilling through pile may be omitted and plug welds may be used to secure cap to pile in place of bolts, see MAGNUM® Technical Bulletin TB004. Snug tighten or post-tension thread bar nut against bearing plate as required for the project.



Bearing Plate & Washers Sold Separately

MAGNUM®
P I E R I N G
designed to support

156 Circle Freeway Dr.
Cincinnati, OH 45246
800-822-7437
www.MagnumPiering.com

MAGNUM® MHC1080-3508B Tie-Back Cap

Allowable Capacity - 17 Tons Tension

(1) 24" #8, Gr. 75 Thread Bar with (1) #8 Nut & 3.63-Inch I.D. Collar
Fits MH3521 & MH3530 Helical Piles

Description: MAGNUM® Tie-Back Caps consist of a collar tube with bolt hole for connection to MAGNUM® helical piles and a thread bar & nut for attachment to various earth retention structures and foundations. The tie-back caps are manufactured in the USA according to our ISO 9001 approved quality program. Structural capacities are developed according to AISC 360 considering an average design life of 75 years for bare steel in most soil conditions. Hot-dip galvanizing is available upon request. Design and detailing of the structure to which the helical tie-back cap is attached varies by project and is the responsibility of registered design professional including but not limited to waler size, bearing plate or wall facing (if any), and concrete cover as applicable.

Specifications	
Collar Tube	0.31" x 3.63" I.D. ASTM A513, Fy = 65 ksi or Better
End Effector	(1) #8 x 24" Gr. 75 Thread Bar & (1) #8 Nut - Plates & Washers Sold Separately
Pile Connection	(1) 1" SAE J429 Grade 8 Zinc Coated to ASTM B695/F1941
Coating	Galvanized per ASTM A153/A123 (G), Bare Steel (NG), or Epoxy Coated per ICC-ES AC228 (EP)
Compatibility	MH3521 & MH3530
Capacity	
Ultimate Compression/Tension	NA / 34 Tons
Allowable Compression/Tension	NA / 17 Tons



Notes: Cap capacity is developed using the ASD design method and considers strength of collar, end effector, and pile connection. Capacity may be limited by the helical pile itself, bearing/pullout capacity of soil, or strength of the structure to which the cap is attached.

Installation Notes: After installation of a MAGNUM® Helical Pile to the correct depth, torque, and capacity, begin by cutting-off the pile shaft at the proper elevation. Drill (1) 1-1/16" hole using the MAGNUM® drill template. Place the pile cap over the shaft and secure with (1) 1" bolt. Snug tighten nuts. Alternatively, drilling through pile may be omitted and plug welds may be used to secure cap to pile in place of bolts, see MAGNUM® Technical Bulletin TB004. Snug tighten or post-tension thread bar nut against bearing plate as required for the project.



Bearing Plate & Washers Sold Separately



156 Circle Freeway Dr.
Cincinnati, OH 45246
800-822-7437
www.MagnumPiering.com

MAGNUM® MHC1080-3514B Tie-Back Cap

Allowable Capacity - 27 Tons Tension

(1) 24" #14, Gr. 75 Thread Bar with (1) #14 Nut & 3.63-Inch I.D. Collar
Fits MH3521 & MH3530 Helical Piles

Description: MAGNUM® Tie-Back Caps consist of a collar tube with bolt hole for connection to MAGNUM® helical piles and a thread bar & nut for attachment to various earth retention structures and foundations. The tie-back caps are manufactured in the USA according to our ISO 9001 approved quality program. Structural capacities are developed according to AISC 360 considering an average design life of 75 years for bare steel in most soil conditions. Hot-dip galvanizing is available upon request. Design and detailing of the structure to which the helical tie-back cap is attached varies by project and is the responsibility of registered design professional including but not limited to waler size, bearing plate or wall facing (if any), and concrete cover as applicable.

Specifications	
Collar Tube	0.31" x 3.63" I.D. ASTM A513, F _y = 65 ksi or Better
End Effector	(1) #14 x 24" Gr. 75 Thread Bar & (1) #14 Nut - Plates & Washers Sold Separately
Pile Connection	(1) 1" SAE J429 Grade 8 Zinc Coated to ASTM B695/F1941
Coating	Galvanized per ASTM A153/A123 (G), Bare Steel (NG), or Epoxy Coated per ICC-ES AC228 (EP)
Compatibility	MH3521 & MH3530
Capacity	
Ultimate Compression/ Tension	NA / 49 Tons
Allowable Compression/ Tension	NA / 27 Tons

Notes: Cap capacity is developed using the ASD design method and considers strength of collar, end effector, and pile connection. Capacity may be limited by the helical pile itself, bearing/pullout capacity of soil, or strength of the structure to which the cap is attached.

Bearing Plate & Washers Sold Separately



Installation Notes: After installation of a MAGNUM® Helical Pile to the correct depth, torque, and capacity, begin by cutting-off the pile shaft at the proper elevation. Drill (1) 1-1/16" hole using the MAGNUM® drill template. Place the pile cap over the shaft and secure with (1) 1" bolt. Snug tighten nuts. Alternatively, drilling through pile may be omitted and plug welds may be used to secure cap to pile in place of bolts, see MAGNUM® Technical Bulletin TB004. Snug tighten or post-tension thread bar nut against bearing plate as required for the project.



MAGNUM®
P I E R I N G
designed to support

156 Circle Freeway Dr.
Cincinnati, OH 45246
800-822-7437
www.MagnumPiering.com

MAGNUM® MHC1080-41024B Tie-Back Cap

Allowable Capacity - 31 Tons Tension

(1) 24" #10, Gr. 75 Thread Bar with (1) #10 Nut & 4.63-Inch I.D. Collar
Fits MH429 & MH434 Helical Piles

Description: MAGNUM® Tie-Back Caps consist of a collar tube with bolts hole for connection to MAGNUM® helical piles and a thread bar & nut for attachment to various earth retention structures and foundations. The tie-back caps are manufactured in the USA according to our ISO 9001 approved quality program. Structural capacities are developed according to AISC 360 considering an average design life of 75 years for bare steel in most soil conditions. Hot-dip galvanizing is available upon request. Design and detailing of the structure to which the helical tie-back cap is attached varies by project and is the responsibility of registered design professional including but not limited to water size, bearing plate or wall facing (if any), and concrete cover as applicable.

Specifications	
Collar Tube	0.31" x 4.63" I.D. ASTM A252, Fy = 65 ksi or Better
End Effector	1) #10 x 24" Gr. 75 Thread Bar & (1) #10 Nut - Plate & Washer Sold Separately
Pile Connection	(2) 1-1/4" SAE J429 Grade 5 Zinc Coated to ASTM B695/F1941
Coating	Galvanized per ASTM A153/A123 (G), Bare Steel (NG), or Epoxy Coated per ICC-ES AC228 (EP)
Compatibility	MH429(-6), MH434(-6)
Capacity	
Ultimate Compression/Tension	NA / 63 Tons
Allowable Compression/Tension	NA / 31 Tons



Notes: Cap capacity is developed using the ASD design method and considers strength of collar, end effector, and pile connection. Capacity may be limited by the helical pile itself, bearing/pullout capacity of soil, or strength of the structure to which the cap is attached.

Installation Notes: After installation of a MAGNUM® Helical Pile to the correct depth, torque, and capacity, begin by cutting-off the pile shaft at the proper elevation. Drill (2) 1-5/16" holes using the MAGNUM® drill template. Place the pile cap over the shaft and secure with (2) 1-1/4" bolts. Snug tighten nuts. Alternatively, drilling through pile may be omitted and plug welds may be used to secure cap to pile in place of bolts, see MAGNUM® Technical Bulletin TB004. Snug tighten or post-tension thread bar nut against bearing plate as required for the project.



Bearing Plate & Washers Sold Separately



156 Circle Freeway Dr.
Cincinnati, OH 45246
800-822-7437
www.MagnumPiering.com

MAGNUM® MHC1080-41424B Tie-Back Cap

Allowable Capacity - 48 Tons Tension

(1) 24" #14, Gr. 75 Thread Bar with (1) #14 Nut & 4.63-Inch I.D. Collar
Fits MH429 & MH434 Helical Piles

Description: MAGNUM® Tie-Back Caps consist of a collar tube with bolt holes for connection to MAGNUM® helical piles and a thread bar & nut for attachment to various earth retention structures and foundations. The tie-back caps are manufactured in the USA according to our ISO 9001 approved quality program. Structural capacities are developed according to AISC 360 considering an average design life of 75 years for bare steel in most soil conditions. Hot-dip galvanizing is available upon request. Design and detailing of the structure to which the helical tie-back cap is attached varies by project and is the responsibility of registered design professional including but not limited to waler size, bearing plate or wall facing (if any), and concrete cover as applicable.

Specifications	
Collar Tube	0.31" x 4.63" I.D. ASTM A252, Fy = 65 ksi or Better
End Effector	(1) #14 x 24" Gr. 75 Thread Bar & (1) #14 Nut - Plate & Washer Sold Separately
Pile Connection	(2) 1-1/4" SAE J429 Grade 5 Zinc Coated to ASTM B695/F1941
Coating	Galvanized per ASTM A153/A123 (G), Bare Steel (NG), or Epoxy Coated per ICC-ES AC228 (EP)
Compatibility	MH429(-6), MH434(-6)
Capacity	
Ultimate Compression/Tension	NA / 97 Tons
Allowable Compression/Tension	NA / 48 Tons

Notes: Cap capacity is developed using the ASD design method and considers strength of collar, end effector, and pile connection. Capacity may be limited by the helical pile itself, bearing/pullout capacity of soil, or strength of the structure to which the cap is attached.



Installation Notes: After installation of a MAGNUM® Helical Anchor or Pile to the correct depth, torque, and capacity, begin by cutting-off the pile shaft at the proper elevation. Drill (2) 1-5/16" holes using the MAGNUM® drill template. Place the pile cap over the shaft and secure with (2) 1-1/4" bolts. Snug tighten nuts. Alternatively, drilling through pile may be omitted and plug welds may be used to secure cap to pile in place of bolts, see MAGNUM® Technical Bulletin TB004. Snug tighten or post-tension thread bar nut against bearing plate as required for the project.



Bearing Plate & Washers Sold Separately

MAGNUM®
PIERING
designed to support

156 Circle Freeway Dr.
Cincinnati, OH 45246
800-822-7437
www.MagnumPiering.com

MAGNUM® MHC1080-52024B Tie-Back Cap

Allowable Capacity - 98 Tons Tension

(1) 24" #20, Gr. 75 Thread Bar with (1) #20 Nut & 5.75-Inch I.D. Collar
 Fits MH530, MH536, MH542 & MH547 Helical Piles

Description: MAGNUM® Tie-Back Caps consist of a collar tube with bolt holes for connection to MAGNUM® helical piles and a thread bar & nut for attachment to various earth retention structures and foundations. The tie-back caps are manufactured in the USA according to our ISO 9001 approved quality program. Structural capacities are developed according to AISC 360 considering an average design life of 75 years for bare steel in most soil conditions. Hot-dip galvanizing is available upon request. Design and detailing of the structure to which the helical tie-back cap is attached varies by project and is the responsibility of registered design professional including but not limited to water size, bearing plate or wall facing (if any), and concrete cover as applicable.

Specifications	
Collar Tube	0.44" x 5.75" I.D. ASTM A252, Fy = 70 ksi or Better
End Effector	(1) #20 x 24" Gr. 75 Thread Bar & #20 Nut - Plate & Washer Sold Separately
Pile Connection	(3) 1-1/2" SAE J429 Grade 5 Zinc Coated to ASTM B695/F1941
Coating	Galvanized per ASTM A153/A123 (G), Bare Steel (NG), or Epoxy Coated per ICC-ES AC228 (EP)
Compatibility	MH530-6, MH536-6, MH542-6, MH547-6
Capacity	
Ultimate Compression/Tension	NA / 196 Tons
Allowable Compression/Tension	NA / 98 Tons

Notes: Cap capacity is developed using the ASD design method and considers strength of collar, end effector, and pile connection. Capacity may be limited by the helical pile itself, bearing/pullout capacity of soil, or strength of the structure to which the cap is attached.



Installation Notes: After installation of a MAGNUM® Helical Anchor or Pile to the correct depth, torque, and capacity, begin by cutting-off the pile shaft at the proper elevation. Drill (3) 1-9/16" holes using the MAGNUM® drill template. Place the pile cap over the shaft and secure with (3) 1-1/2" bolts. Snug tighten nuts. Alternatively, drilling through pile may be omitted and plug welds may be used to secure cap to pile in place of bolts, see MAGNUM® Technical Bulletin TB004. Snug tighten or post-tension thread bar nut against bearing plate as required for the project.

Bearing Plate & Washers Sold Separately



156 Circle Freeway Dr.
 Cincinnati, OH 45246
 800-822-7437
www.MagnumPiering.com

MAGNUM® MSC1084-150B Tie-Back Cap

Allowable Capacity - 20 Tons Tension

Clevis Side Plates & End Plate with 1.125" Hole for #8 Thread Bar
Fits MS150 Helical Piers

Description: MAGNUM® Clevis Tie-Back Caps consist of two clevis plates and a square end plate with a hole for connection with a #8 threaded rod. The clevis tie-back caps are manufactured in the USA according to our ISO 9001 approved quality program. Structural capacities are developed according to AISC 360 considering an average design life of 75 years for bare steel in most soil conditions. Hot-dip galvanizing is available upon request. Design and detailing of the structure to which the clevis tie-back cap is attached varies by project and is the responsibility of registered design professional including but not limited to water size, bearing plate or wall facing (if any), and concrete cover as applicable.

Specifications	
Collar Tube	0.5" x 3" x 7" Clevis Plates, ASTM A36, Fy = 36 ksi or Better
End Effector	3.75" x 3.75" x 0.625" End Plate with (1) 1.125" Diameter Hole
Pile Connection	(1) 7/8" SAE J429 Grade 8 Zinc Coated to ASTM B695/F1941
Coating	Galvanized per ASTM A153/A123 (G), Bare Steel (NG), or Epoxy Coated per ICC-ES AC228 (EP)
Compatibility	MS150B
Capacity	
Ultimate Compression/ Tension	NA / 35 Tons
Allowable Compression/ Tension	NA / 20 Tons



Notes: Cap capacity considers tension in line with the pile. Ensure thread bar nut has sufficient bearing on the end plate. Add washers if necessary.

Installation Notes: After installation of the MAGNUM® Helical Pile to the correct depth, torque and capacity, cut off the pile shaft at the proper elevation. Drill (1) 15/16" diameter hole through the shaft using a MAGNUM® drill template. Place the anchor cap over the shaft and secure with (1) 7/8" bolt. Snug tighten nut. Pass thread bar with nut through the hole in the end plate and make necessary attachments.



Thread bar, Nut and Washers Sold Separately

MAGNUM®
PIERING
designed to support

156 Circle Freeway Dr.
Cincinnati, OH 45246
800-822-7437
www.MagnumPiering.com

MAGNUM® MSC1084-175B Tie-Back Cap

Allowable Capacity - 26.7 Tons Tension

Clevis Side Plates & End Plate with 1.25" Hole for #9 Thread Bar

Fits MS175 Helical Piers

Description: MAGNUM® Clevis Tie-Back Caps consist of two clevis plates and a square end plate with a hole for connection with a #8 threaded rod. The clevis tie-back caps are manufactured in the USA according to our ISO 9001 approved quality program. Structural capacities are developed according to AISC 360 considering an average design life of 75 years for bare steel in most soil conditions. Hot-dip galvanizing is available upon request. Design and detailing of the structure to which the clevis tie-back cap is attached varies by project and is the responsibility of registered design professional including but not limited to waler size, bearing plate or wall facing (if any), and concrete cover as applicable.

Specifications	
Collar Tube	0.5" x 3-5/8" x 8" Clevis Plates, ASTM A36, Fy = 36 ksi or Better
End Effector	4" x 4" x 0.625" End Plate with (1) 1.25" Diameter Hole
Pile Connection	(1) 1" SAE J429 Grade 8 Zinc Coated to ASTM B695/F1941
Coating	Galvanized per ASTM A153/A123 (G), Bare Steel (NG), or Epoxy Coated per ICC-ES AC228 (EP)
Compatibility	MS175B
Capacity	
Ultimate Compression/Tension	NA / 45 Tons
Allowable Compression/Tension	NA / 26.7 Tons



Notes: Cap capacity considers tension in line with the pile. Ensure thread bar nut has sufficient bearing on the end plate. Add washers if necessary.

Installation Notes: After installation of the MAGNUM® Helical Pile to the correct depth, torque and capacity, cut off the pile shaft at the proper elevation. Drill (1) 1-1/16" diameter hole through the shaft using a MAGNUM® drill template. Place the anchor cap over the shaft and secure with (1) 1" bolt. Snug tighten nut. Pass thread bar with nut through the hole in the end plate and make necessary attachments.



Thread bar, Nut and Washers Sold Separately



156 Circle Freeway Dr.
Cincinnati, OH 45246
800-822-7437
www.MagnumPiering.com

MAGNUM® MSC1172-175B1 Guy Anchor Cap

Allowable Capacity - 22 Tons Tension

4" x 6" x 1-1/4" Tension Lug & 2.375-Inch I.D. Collar

Fits MS175 Helical Piers

Description: MAGNUM® Guy Anchor Caps consist of a collar tube with bolt hole for connection to MAGNUM® helical piles and a tension lug with a 2-1/8" hole for shackle attachment. The guy anchor caps are manufactured in the USA according to our ISO 9001 approved quality program. Structural capacities are developed according to AISC 360 considering an average design life of 75 years for hot-dip galvanized steel in most soil conditions. Bare steel is available upon request. Design and detailing of the structure to which the guy anchor cap is attached varies by project and is the responsibility of registered design professional.

Specifications	
Collar Tube	0.25" x 2.375" I.D. ASTM A513, Fy = 65 ksi or Better
End Effector	4" x 6" x 1-1/4" plate w/ 2-1/8" hole. ASTM A36
Pile Connection	(1) 1" SAE J429 Grade 8 Zinc Coated to ASTM B695/F1941
Coating	Galvanized per ASTM A153/A123 (G), Bare Steel (NG), or Epoxy Coated per ICC-ES AC228 (EP)
Compatibility	MS175B
Capacity	
Ultimate Compression/ Tension	NA / 39 Tons
Allowable Compression/ Tension	NA / 22 Tons



Notes: Cap capacity considers tension in line with the pile. Ensure shackle pin diameter is at least 1-1/2 inch for full capacity of the cap. Strength of the shackle and any other attachment is the responsibility of registered design professional.



Installation Notes: After installation of a MAGNUM® Helical Pile to the correct depth, torque and capacity, cut-off the pile shaft at the proper elevation. Drill (1) 1-1/16" diameter holes through the shaft using a MAGNUM® drill template. Place the pile cap over the shaft and secure with (1) 1" bolts. Snug tighten nuts. Alternatively, drilling through pile may be omitted and plug welds may be used to secure cap to pile in place of bolt, see MAGNUM® Technical Bulletin TB004.

MAGNUM®
P I E R I N G
designed to support

156 Circle Freeway Dr.
Cincinnati, OH 45246
800-822-7437
www.MagnumPiering.com

MAGNUM® MHC1172-3BR2 Guy Anchor Cap

Allowable Capacity - 25 Tons Tension

4" x 5-1/2" x 1-1/4" Tension Lug & 3.13-Inch I.D. Collar

Fits MH325BR(-6) Helical Piles

Description: MAGNUM® Guy Anchor Caps consist of a collar tube with bolt holes for connection to MAGNUM® helical piles and a tension lug with a 2-1/8" hole for shackle attachment. The guy anchor caps are manufactured in the USA according to our ISO 9001 approved quality program. Structural capacities are developed according to AISC 360 considering an average design life of 75 years for hot-dip galvanized steel in most soil conditions. Bare steel is available upon request. Design and detailing of the structure to which the guy anchor cap is attached varies by project and is the responsibility of registered design professional.

Specifications	
Collar Tube	0.31" x 3.13" I.D. ASTM A513, Fy = 65 ksi or Better
End Effector	4" x 5-1/2" x 1-1/4" plate w/ 2-1/8" hole. ASTM A36
Pile Connection	(2) 1" SAE J429 Grade 8 Zinc Coated to ASTM B695/F1941
Coating	Galvanized per ASTM A153/A123 (G), Bare Steel (NG), or Epoxy Coated per ICC-ES AC228 (EP)
Compatibility	MH325BR(-6)
Capacity	
Ultimate Compression/ Tension	NA / 45 Tons
Allowable Compression/ Tension	NA / 25 Tons



Notes: Cap capacity considers tension in line with the pile. Ensure shackle pin diameter is at least 1-1/2 inch for full capacity of the cap. Strength of the shackle and any other attachment is the responsibility of registered design professional.



Installation Notes: After installation of a MAGNUM® Helical Pile to the correct depth, torque and capacity, cut-off the pile shaft at the proper elevation. Drill (2) 1-1/16" diameter holes through the shaft using a MAGNUM® drill template. Place the pile cap over the shaft and secure with (2) 1" bolts. Snug tighten nuts. Alternatively, drilling through pile may be omitted and plug welds may be used to secure cap to pile in place of bolt, see MAGNUM® Technical Bulletin TB004.



156 Circle Freeway Dr.
Cincinnati, OH 45246
800-822-7437
www.MagnumPiering.com

MAGNUM® MHC1172-4B2 Guy Anchor Cap

Allowable Capacity - 36 Tons Tension

4-3/4" x 6" x 1-1/2" Tension Lug & 4.63-Inch I.D. Collar

Fits MH429 & MH434 Helical Piles

Description: MAGNUM® Guy Anchor Caps consist of a collar tube with bolt holes for connection to MAGNUM® helical piles and a tension lug with a 2-1/2" hole for shackle attachment. The guy anchor caps are manufactured in the USA according to our ISO 9001 approved quality program. Structural capacities are developed according to AISC 360 considering an average design life of 75 years for hot-dip galvanized steel in most soil conditions. Bare steel is available upon request. Design and detailing of the structure to which the guy anchor cap is attached varies by project and is the responsibility of registered design professional.

Specifications	
Collar Tube	0.31" x 4.63" I.D. ASTM A252, Fy = 65 ksi or Better
End Effector	4-3/4" x 6" x 1-1/2" plate w/ 2-1/2" hole. ASTM A36
Pile Connection	(2) 1-1/4" SAE J429 Grade 5 Zinc Coated to ASTM B695/F1941
Coating	Galvanized per ASTM A153/A123 (G), Bare Steel (NG), or Epoxy Coated per ICC-ES AC228 (EP)
Compatibility	MH429(-6), MH434(-6)
Capacity	
Ultimate Compression/ Tension	NA / 65 Tons
Allowable Compression/ Tension	NA / 36 Tons



Notes: Cap capacity considers tension in line with the pile. Ensure shackle pin diameter is at least 2 inch for full capacity of the cap. Strength of the shackle and any other attachment is the responsibility of registered design professional.

Installation Notes: After installation of a MAGNUM® Helical Pile to the correct depth, torque and capacity, cut-off the pile shaft at the proper elevation. Drill (2) 1-5/16" diameter holes through the shaft using a MAGNUM® drill template. Place the pile cap over the shaft and secure with (2) 1-1/4" bolts. Snug tighten nuts. Alternatively, drilling through pile may be omitted and plug welds may be used to secure cap to pile in place of bolt, see MAGNUM® Technical Bulletin TB004.



MAGNUM®
P I E R I N G
designed to support

156 Circle Freeway Dr.
Cincinnati, OH 45246
800-822-7437
www.MagnumPiering.com

MAGNUM® MHC1172-5B2 Guy Anchor Cap

Allowable Capacity - 78 Tons Tension

6" x 8" x 2" Tension Lug & 5.75-Inch I.D. Collar

Fits MH530, MH536, MH542 & MH547 Helical Piles

Description: MAGNUM® Guy Anchor Caps consist of a collar tube with bolt holes for connection to MAGNUM® helical piles and a tension lug with a 3" hole for shackle attachment. The guy anchor caps are manufactured in the USA according to our ISO 9001 approved quality program. Structural capacities are developed according to AISC 360 considering an average design life of 75 years for hot-dip galvanized steel in most soil conditions. Bare steel is available upon request. Design and detailing of the structure to which the guy anchor cap is attached varies by project and is the responsibility of registered design professional.

Specifications	
Collar Tube	0.44" x 5.75" I.D. ASTM A252, Fy = 70 ksi or Better
End Effector	6"x8"x2" plate w/ 3" hole. ASTM A36
Pile Connection	(2) 1-1/2" SAE J429 Grade 5 Zinc Coated to ASTM B695/F1941
Coating	Galvanized per ASTM A153/A123 (G), Bare Steel (NG), or Epoxy Coated per ICC-ES AC228 (EP)
Compatibility	MH530-6, MH536-6, MH542-6, MH547-6
Capacity	
Ultimate Compression/ Tension	NA / 156 Tons
Allowable Compression/ Tension	NA / 78 Tons

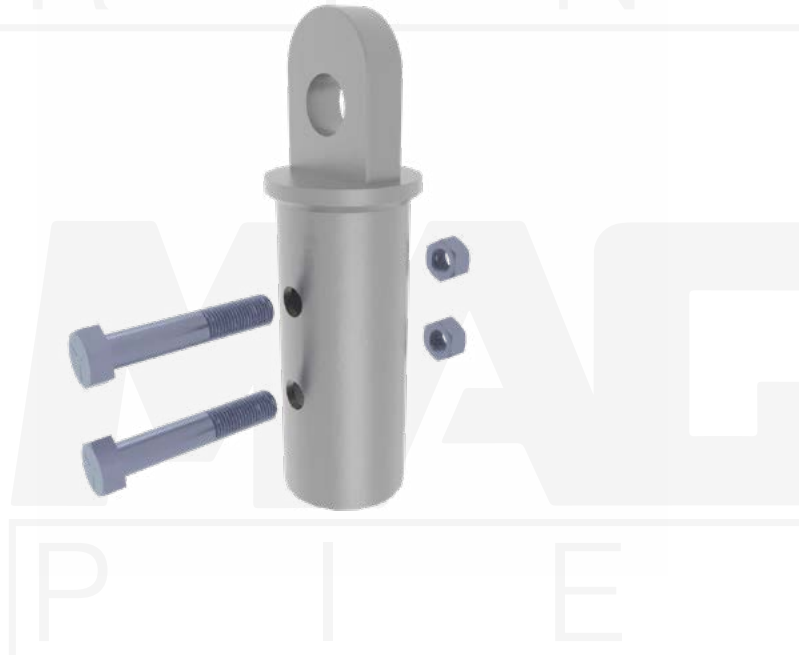

Notes: Cap capacity considers tension in line with the pile. Ensure shackle pin diameter is at least 2-1/2 inch for full capacity of the cap. Strength of the shackle and any other attachment is the responsibility of registered design professional.

Installation Notes: After installation of a MAGNUM® Helical Pile to the correct depth, torque and capacity, cut-off the pile shaft at the proper elevation. Drill (2) 1-9/16" diameter holes through the shaft using a MAGNUM® drill template. Place the pile cap over the shaft and secure with (2) 1-1/2" bolts. Snug tighten nuts. Alternatively, drilling through pile may be omitted and plug welds may be used to secure cap to pile in place of bolt, see MAGNUM® Technical Bulletin TB004.



156 Circle Freeway Dr.
Cincinnati, OH 45246
800-822-7437
www.MagnumPiering.com

MAGNUM® MHC1000-3B Grade Beam Cap

Allowable Capacity 25 Tons Compression / 16 Tons Tension

(2) #7 Reinforcing Steel Bars Horizontal & 3.13-Inch I.D. Collar
Fits MH313B, MH313BR & MH325B Helical Piles

Description: MAGNUM® Grade Beam Caps consist of a collar tube with bolt hole for connection to MAGNUM® helical piles and horizontal reinforcing steel bars for embedment in cast-in-place reinforced concrete. MAGNUM® products are manufactured in the USA according to our ISO 9001 approved quality program. Structural capacities are developed according to AISC 360 and ACI 318 considering an average design life of 75 years for bare steel in most soil conditions. Hot-dip galvanizing is available upon request. Design and detailing of the structure to which bearing plate cap is embedded in varies by project and is the responsibility of the registered design professional.

Specifications	
Collar Tube	0.25" x 3.13" I.D. ASTM A513, Fy = 65 ksi or Better
End Effector	(2) #7 ASTM A706 GR. 60 Bars Horizontal
Pile Connection	(1) 7/8" SAE J429 Grade 5 Zinc Coated to ASTM B695/F1941
Coating	Galvanized per ASTM A153/A123 (G), Bare Steel (NG), or Epoxy Coated per ICC-ES AC228 (EP)
Compatibility	MH313B, MH313BR, MH325B
Capacity	
Ultimate Compression/ Tension	50 Tons / 32 Tons
Allowable Compression/ Tension	25 Tons / 16 Tons

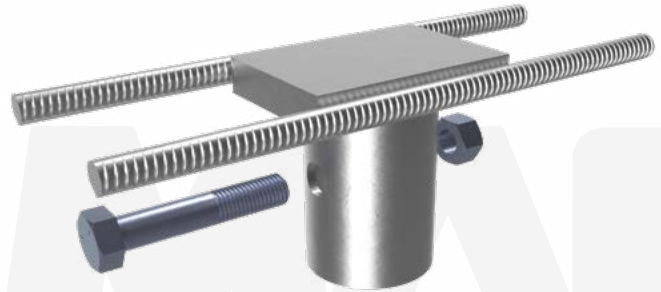

Notes: Cap capacity is developed using the ASD design method and considers strength of collar, end effector, and pile connection. Capacity may be limited by the helical pile, bearing/pullout capacity of soil, or strength of the concrete the cap is embedded in.

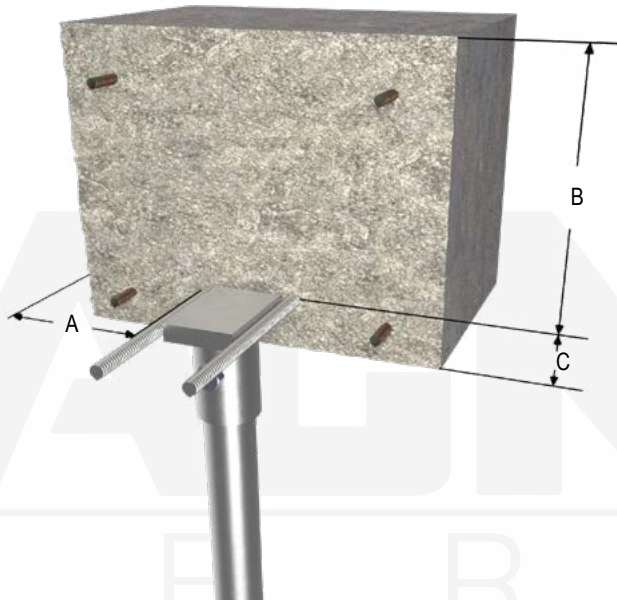

A - As Required for Shear (Min. 4" per IBC)
B - As required for Compression. See pages 186-187.
C - As Required for Tension (Min. 3" per IBC). See pages 186-187.

Installation Notes: After installation of a MAGNUM® Helical Pile to the correct depth, torque, and capacity, cut-off the pile shaft at the proper elevation. Drill (1) 15/16" diameter hole through the shaft using a MAGNUM® drill template, place the cap over the shaft and secure with (1) 7/8" bolt. Snug tighten nut. Alternatively, drilling through pile may be omitted and plug welds may be used to secure cap to pile in place of bolt, see MAGNUM® Technical Bulletin TB004. Ensure direct bearing of plate on shaft. Place reinforcing steel, cast concrete and consolidate around the pile cap per project requirements.

MAGNUM®
P I E R I N G
designed to support

156 Circle Freeway Dr.
Cincinnati, OH 45246
800-822-7437
www.MagnumPiering.com

MAGNUM® MHC1000-3BR2 Grade Beam Cap

Allowable Capacity 25 Tons Compression / 25 Tons Tension

(2) #7 Reinforcing Steel Bars Horizontal & 3.13-Inch I.D. Collar
 Fits MH325BR(-6) Helical Piles

Description: MAGNUM® Grade Beam Caps consist of a collar tube with bolt hole for connection to MAGNUM® helical piles and horizontal reinforcing steel bars for embedment in cast-in-place reinforced concrete. MAGNUM® products are manufactured in the USA according to our ISO 9001 approved quality program. Structural capacities are developed according to AISC 360 and ACI 318 considering an average design life of 75 years for bare steel in most soil conditions. Hot-dip galvanizing is available upon request. Design and detailing of the structure to which bearing plate cap is embedded in varies by project and is the responsibility of the registered design professional.

Concrete

Specifications	
Collar Tube	0.31" x 3.13" I.D. ASTM A513, Fy = 65 ksi or Better
End Effector	(2) #7 ASTM A706 GR. 60 Bars Horizontal
Pile Connection	(2) 1" SAE J429 Grade 8 Zinc Coated to ASTM B695/F1941
Coating	Galvanized per ASTM A153/A123 (G), Bare Steel (NG), or Epoxy Coated per ICC-ES AC228 (EP)
Compatibility	MH325BR(-6)
Capacity	
Ultimate Compression/ Tension	50 Tons / 50 Tons
Allowable Compression/ Tension	25 Tons / 25 Tons



Notes: Cap capacity is developed using the ASD design method and considers strength of collar, end effector, and pile connection. Capacity may be limited by the helical pile, bearing/pullout capacity of soil, or strength of the concrete the cap is embedded in.

Installation Notes: After installation of a MAGNUM® Helical Pile to the correct depth, torque, and capacity, cut-off the pile shaft at the proper elevation. Drill (2) 1-1/16" diameter holes through the shaft using a MAGNUM® drill template, place the cap over the shaft and secure with (2) 1" bolts. Snug tighten nut. Alternatively, drilling through pile may be omitted and plug welds may be used to secure cap to pile in place of bolt, see MAGNUM® Technical Bulletin TB004. Ensure direct bearing of plate on shaft. Place reinforcing steel, cast concrete and consolidate around the pile cap per project requirements.

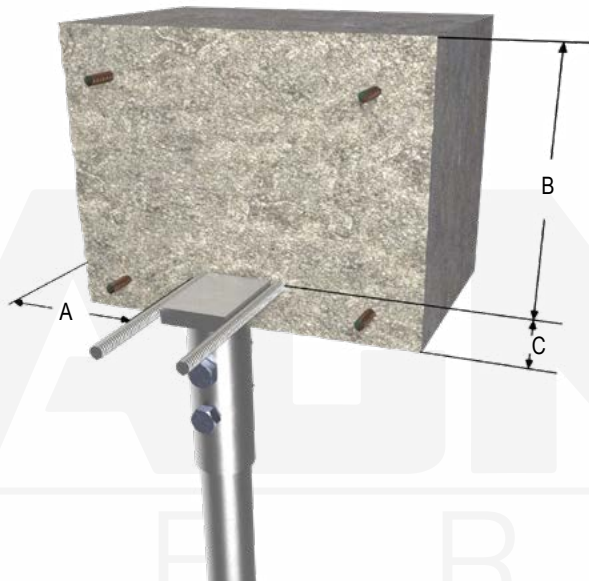

- A - As Required for Shear (Min. 4" per IBC)
- B - As required for Compression. See pages 186-187.
- C - As Required for Tension (Min. 3" per IBC). See pages 186-187.



156 Circle Freeway Dr.
 Cincinnati, OH 45246
 800-822-7437
www.MagnumPiering.com

MAGNUM® MSC1040-150B Bond Bar Cap

Allowable Capacity 17.5 Tons Compression & Tension

(2) #7 Reinforcing Steel Bars Vertical & 2-Inch I.D. Collar
Fits MS150 Helical Piers

Description: MAGNUM® Bond Bar Cap consist of a collar tube with bolt hole for connection to MAGNUM® helical piles and vertical reinforcing steel bars for embedment in cast-in-place reinforced concrete. MAGNUM® products are manufactured in the USA according to our ISO 9001 approved quality program. Structural capacities are developed according to AISC 360 and ACI 318 considering an average design life of 75 years for bare steel in most soil conditions. Hot-dip galvanizing is available upon request. Design and detailing of the structure to which bearing plate cap is embedded in varies by project and is the responsibility of the registered design professional.

Specifications	
Collar Tube	0.25" x 2" I.D. Square ASTM A513, Fy = 65 ksi or Better
End Effector	(2) #7 ASTM A706 GR-60 Bars Vertical
Pile Connection	(1) 7/8" SAE J429 Grade 5 Zinc Coated to ASTM B695/F1941
Coating	Galvanized per ASTM A153/A123 (G), Bare Steel (NG), or Epoxy Coated per ICC-ES AC228 (EP)
Compatibility	MS150B
Capacity	
Ultimate Compression/ Tension	35 Tons / 35 Tons
Allowable Compression/ Tension	17.5 Tons / 17.5 Tons

Notes: Cap capacity is developed using the ASD design method and considers strength of collar, end effector, and pile connection. Capacity may be limited by the helical pile, bearing/pullout capacity of soil, or strength of the concrete the cap is embedded in.



A- Min. 4" per IBC



Installation Notes: After installation of a MAGNUM® Helical Pier to the correct depth, torque, and capacity, cut-off the pile shaft at the proper elevation. Drill (1) 15/16" diameter hole through the shaft using a MAGNUM® drill template, place the cap over the shaft and secure with (1) 7/8" bolt. Snug tighten nut. Reinforcing steel development length to be checked by registered design professional. Place reinforcing steel, cast concrete and consolidate around the pile cap per project requirements.

MAGNUM®
P I E R I N G
designed to support

156 Circle Freeway Dr.
Cincinnati, OH 45246
800-822-7437
www.MagnumPiering.com

MAGNUM® MSC1040-175B Bond Bar Cap

Allowable Capacity 27.5 Tons Compression & Tension

(3) #7 Reinforcing Steel Bars Vertical & 2.375-Inch I.D. Collar
Fits MS175 Helical Piers

Description: MAGNUM® Bond Bar Cap consist of a collar tube with bolt hole for connection to MAGNUM® helical piles and vertical reinforcing steel bars for embedment in cast-in-place reinforced concrete. MAGNUM® products are manufactured in the USA according to our ISO 9001 approved quality program. Structural capacities are developed according to AISC 360 and ACI 318 considering an average design life of 75 years for bare steel in most soil conditions. Hot-dip galvanizing is available upon request. Design and detailing of the structure to which bearing plate cap is embedded in varies by project and is the responsibility of the registered design professional.

Concrete

Specifications	
Collar Tube	0.25" x 2.375" I.D. ASTM A513, Fy = 65 ksi or Better
End Effector	(3) #7 ASTM A706 GR-60 Bars Vertical
Pile Connection	(1) 1" SAE J429 Grade 8 Zinc Coated to ASTM B695/F1941
Coating	Galvanized per ASTM A153/A123 (G), Bare Steel (NG), or Epoxy Coated per ICC-ES AC228 (EP)
Compatibility	MS175B
Capacity	
Ultimate Compression/ Tension	55 Tons / 55 Tons
Allowable Compression/ Tension	27.5 Tons / 27.5 Tons

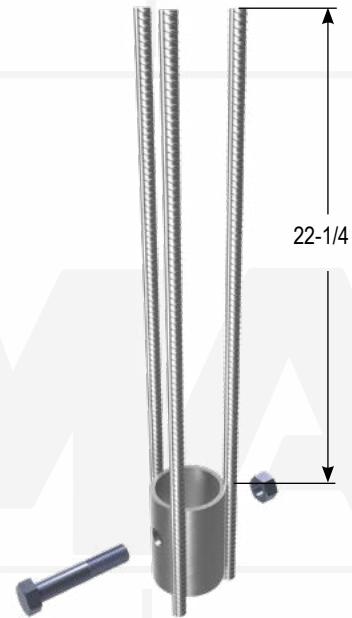

Notes: Cap capacity is developed using the ASD design method and considers strength of collar, end effector, and pile connection. Capacity may be limited by the helical pile, bearing/pullout capacity of soil, or strength of the concrete the cap is embedded in.

Installation Notes: After installation of a MAGNUM® Helical Pier to the correct depth, torque, and capacity, cut-off the pile shaft at the proper elevation. Drill (1) 1-1/16" diameter hole through the shaft using a MAGNUM® drill template, place the cap over the shaft and secure with (1) 1" bolt. Snug tighten nut. Reinforcing steel development length to be checked by registered design professional. Place reinforcing steel, cast concrete and consolidate around the pile cap per project requirements.



A- Min. 4" per IBC



156 Circle Freeway Dr.
Cincinnati, OH 45246
800-822-7437

www.MagnumPiering.com

MAGNUM® MHC1040-3B Bond Bar Cap

Allowable Capacity 16 Tons Compression / 16 Tons Tension

(2) #7 Reinforcing Steel Bars Vertical & 3.13-Inch I.D. Collar
Fits MH313B, MH313BR & MH325B Helical Piles

Description: MAGNUM® Bond Bar Cap consist of a collar tube with bolt hole for connection to MAGNUM® helical piles and vertical reinforcing steel bars for embedment in cast-in-place reinforced concrete. MAGNUM® products are manufactured in the USA according to our ISO 9001 approved quality program. Structural capacities are developed according to AISC 360 and ACI 318 considering an average design life of 75 years for bare steel in most soil conditions. Hot-dip galvanizing is available upon request. Design and detailing of the structure to which bearing plate cap is embedded in varies by project and is the responsibility of the registered design professional.

Specifications	
Collar Tube	0.25" x 3.13" I.D. ASTM A513, Fy = 65 ksi or Better
End Effector	(2) #7 ASTM A706 GR. 60 Bars Vertical
Pile Connection	(1) 7/8" SAE J429 Grade 5 Zinc Coated to ASTM B695/F1941
Coating	Galvanized per ASTM A153/A123 (G), Bare Steel (NG), or Epoxy Coated per ICC-ES AC228 (EP)
Compatibility	MH313B, MH313BR, MH325B
Capacity	
Ultimate Compression/ Tension	32 Tons / 32 Tons
Allowable Compression/ Tension	16 Tons / 16 Tons

Notes: Cap capacity is developed using the ASD design method and considers strength of collar, end effector, and pile connection. Capacity may be limited by the helical pile, bearing/pullout capacity of soil, or strength of the concrete the cap is embedded in.



A- Min. 4" per IBC



Installation Notes: After installation of a MAGNUM® Helical Pile to the correct depth, torque, and capacity, cut-off the pile shaft at the proper elevation. Drill (1) 15/16" diameter hole through the shaft using a MAGNUM® drill template, place the cap over the shaft and secure with (1) 7/8" bolt. Snug tighten nut. Reinforcing steel development length to be checked by registered design professional. Place reinforcing steel, cast concrete and consolidate around the pile cap per project requirements.

MAGNUM®
P I E R I N G
designed to support

156 Circle Freeway Dr.
Cincinnati, OH 45246
800-822-7437
www.MagnumPiering.com

MAGNUM® MHC1040-3BR2 Bond Bar Cap

Allowable Capacity 19 Tons Compression / 19 Tons Tension

(4) #5 Reinforcing Steel Bars Vertical & 3.13-Inch I.D. Collar
Fits MH325BR(-6) Helical Piles

Description: MAGNUM® Bond Bar Cap consist of a collar tube with bolt holes for connection to MAGNUM® helical piles and vertical reinforcing steel bars for embedment in cast-in-place reinforced concrete. MAGNUM® products are manufactured in the USA according to our ISO 9001 approved quality program. Structural capacities are developed according to AISC 360 and ACI 318 considering an average design life of 75 years for bare steel in most soil conditions. Hot-dip galvanizing is available upon request. Design and detailing of the structure to which bearing plate cap is embedded in varies by project and is the responsibility of the registered design professional.

Concrete

Specifications	
Collar Tube	0.31" x 3.13" I.D. ASTM A513, Fy = 65 ksi or Better
End Effector	(4) #5 ASTM A706 GR. 60 Bars Vertical
Pile Connection	(2) 1" SAE J429 Grade 8 Zinc Coated to ASTM B695/F1941
Coating	Galvanized per ASTM A153/A123 (G), Bare Steel (NG), or Epoxy Coated per ICC-ES AC228 (EP)
Compatibility	MH325BR(-6)
Capacity	
Ultimate Compression/ Tension	38 Tons / 38 Tons
Allowable Compression/ Tension	19 Tons / 19 Tons



Notes: Cap capacity is developed using the ASD design method and considers strength of collar, end effector, and pile connection. Capacity may be limited by the helical pile, bearing/pullout capacity of soil, or strength of the concrete the cap is embedded in.

Installation Notes: After installation of a MAGNUM® Helical Pile to the correct depth, torque, and capacity, cut-off the pile shaft at the proper elevation. Drill (2) 1-1/16" diameter holes through the shaft using a MAGNUM® drill template, place the cap over the shaft and secure with (2) 1" bolts. Snug tighten nuts. Reinforcing steel development length to be checked by registered design professional. Place reinforcing steel, cast concrete and consolidate around the pile cap per project requirements.



A- Min. 4" per IBC

MAGNUM
PIERING
designed to support

156 Circle Freeway Dr.
Cincinnati, OH 45246
800-822-7437

www.MagnumPiering.com

MAGNUM® MHC1040-4B Bond Bar Cap

Allowable Capacity 36 Tons Compression / 36 Tons Tension

(4) #7 Reinforcing Steel Bars Vertical & 4.63-Inch I.D. Collar
Fits MH429 & MH434 Helical Piles

Description: MAGNUM® Bond Bar Cap consist of a collar tube with bolt holes for connection to MAGNUM® helical piles and vertical reinforcing steel bars for embedment in cast-in-place reinforced concrete. MAGNUM® products are manufactured in the USA according to our ISO 9001 approved quality program. Structural capacities are developed according to AISC 360 and ACI 318 considering an average design life of 75 years for bare steel in most soil conditions. Hot-dip galvanizing is available upon request. Design and detailing of the structure to which bearing plate cap is embedded in varies by project and is the responsibility of the registered design professional.

Specifications	
Collar Tube	0.31" x 4.63" I.D. ASTM A252, Fy = 65 ksi or Better
End Effector	(4) #7 ASTM A706 GR. 60 Bars Vertical
Pile Connection	(2) 1-1/4" SAE J429 Grade 5 Zinc Coated to ASTM B695/F1941
Coating	Galvanized per ASTM A153/A123 (G), Bare Steel (NG), or Epoxy Coated per ICC-ES AC228 (EP)
Compatibility	MH429(-6), MH434(-6)
Capacity	
Ultimate Compression/ Tension	72 Tons / 72 Tons
Allowable Compression/ Tension	36 Tons / 36 Tons

Notes: Cap capacity is developed using the ASD design method and considers strength of collar, end effector, and pile connection. Capacity may be limited by the helical pile, bearing/pullout capacity of soil, or strength of the concrete the cap is embedded in.



A- Min. 4" per IBC



Installation Notes: After installation of a MAGNUM® Helical Pile to the correct depth, torque, and capacity, cut-off the pile shaft at the proper elevation. Drill (2) 1-5/16" diameter holes through the shaft using a MAGNUM® drill template, place the cap over the shaft and secure with (2) 1-1/4" bolts. Snug tighten nuts. Reinforcing steel development length to be checked by registered design professional. Place reinforcing steel, cast concrete and consolidate around the pile cap per project requirements.

MAGNUM®
P I E R I N G
designed to support

156 Circle Freeway Dr.
Cincinnati, OH 45246
800-822-7437
www.MagnumPiering.com

MAGNUM® MHC1100-316 Slab Lift Cap

Allowable Capacity - 14 Tons Compression

16" Channel & Lifting Bolt Assembly with 3.13-Inch I.D. Collar

Fits MH313B, MH313BR, MH325B & MH325BR(-6) Helical Piles

Description: MAGNUM® Slab Lift Caps consist of a collar tube for connection to MAGNUM® helical piles and a channel and lifting bolt for insertion under existing slabs. MAGNUM® products are manufactured in the USA according to our ISO 9001 approved quality program. Structural capacities are developed according to AISC 360 and ACI 318 considering an average design life of 75 years for bare steel in most soil conditions. Hot-dip galvanizing is available upon request. Design and detailing of the structure, to which bearing plate cap is attached varies by project and is the responsibility of the registered design professional, including maximum span of slab.

Concrete

Specifications	
Collar Tube	0.25" x 3.13" I.D. ASTM A513, Fy = 65 ksi or Better
End Effector	6" x 3-1/2" x 3/8" – 16" Long Channel and a 1-1/8" Lifting Bolt
Pile Connection	Direct Bearing on Pile Shaft Zinc Coated to ASTM B695/F1941
Coating	Galvanized per ASTM A153/A123 (G), Bare Steel (NG), or Epoxy Coated per ICC-ES AC228 (EP)
Compatibility	MH313B, MH313BR, MH325B, MH325BR(-6)
Capacity	
Ultimate Compression/ Tension	28 Tons
Allowable Compression/ Tension	14 Tons

Notes: Cap capacity is developed using the ASD design method and considers strength of collar, end effector, and pile connection. Capacity may be limited by the helical pile, bearing/pullout capacity of soil, or strength of the concrete the cap is embedded in.

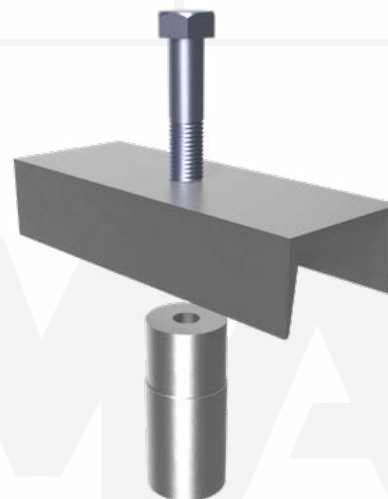

Installation Notes: Core a hole through the slab slightly larger than the largest helix. Excavate a void large enough to facilitate channel installation. Install a MAGNUM® Helical Pile to the correct depth, torque, and capacity. Cut-off the pile shaft at the proper elevation. Place the pile cap over the shaft. Place the channel under the slab with lifting bolt in place. Tighten the lifting bolt to raise the slab elevation as needed. Fill the void under the slab and core hole with fast-setting, high-strength, non-shrink grout.



156 Circle Freeway Dr.
Cincinnati, OH 45246
800-822-7437
www.MagnumPiering.com

MAGNUM® MHC1100-336 Slab Lift Cap

Allowable Capacity - 14 Tons Compression

36" Channel with Lifting Bolt Assembly & 3.13-Inch I.D. Collar

Fits MH313B, MH313BR, MH325B & MH325BR(-6) Helical Piles

Description: MAGNUM® Slab Lift Caps consist of a collar tube for connection to MAGNUM® helical piles and a channel and lifting bolt for insertion under existing slabs. MAGNUM® products are manufactured in the USA according to our ISO 9001 approved quality program. Structural capacities are developed according to AISC 360 and ACI 318 considering an average design life of 75 years for bare steel in most soil conditions. Hot-dip galvanizing is available upon request. Design and detailing of the structure, to which bearing plate cap is attached varies by project and is the responsibility of the registered design professional, including maximum span of slab.

Specifications	
Collar Tube	0.25" x 3.13" I.D. ASTM A513, Fy = 65 ksi or Better
End Effector	6" x 3-1/2" x 3/8" – 36" Long Channel and a 1-1/8" Lifting Bolt
Pile Connection	Direct Bearing on Pile Shaft Zinc Coated to ASTM B695/F1941
Coating	Galvanized per ASTM A153/A123 (G), Bare Steel (NG), or Epoxy Coated per ICC-ES AC228 (EP)
Compatibility	MH313B, MH313BR, MH325B, MH325BR(-6)
Capacity	
Ultimate Compression/ Tension	28 Tons
Allowable Compression/ Tension	14 Tons



Notes: Cap capacity is developed using the ASD design method and considers strength of collar, end effector, and pile connection. Capacity may be limited by the helical pile, bearing/pullout capacity of soil, or strength of the concrete the cap is embedded in.

Installation Notes: Core a hole through the slab slightly larger than the largest helix. Excavate a void large enough to facilitate channel installation. Install a MAGNUM® Helical Pile to the correct depth, torque, and capacity. Cut-off the pile shaft at the proper elevation. Place the pile cap over the shaft. Place the channel under the slab with lifting bolt in place. Tighten the lifting bolt to raise the slab elevation as needed. Fill the void under the slab and core hole with fast-setting, high-strength, non-shrink grout.



MAGNUM®
P I E R I N G
designed to support

156 Circle Freeway Dr.
Cincinnati, OH 45246
800-822-7437
www.MagnumPiering.com

MAGNUM® MSC1300-150M55B Bearing Plate Cap

Allowable Capacity 16 Tons Compression / 14 Tons Tension

5" x 5" x 5/8" Bearing Plate & 2-Inch I.D. Collar
Fits MS150 Helical Piers

Description: MAGNUM® Bearing Plate Caps consist of a collar tube with bolt hole for connection to MAGNUM® helical piles and steel bearing plate for embedment in cast-in-place concrete. MAGNUM® products are manufactured in the USA according to our ISO 9001 approved quality program. Structural capacities are developed according to AISC 360 and ACI 318 considering an average design life of 75 years for bare steel in most soil conditions. Hot-dip galvanizing is available upon request. Design and detailing of the structure to which the bearing plate cap is embedded in varies by project and is the responsibility of the registered design professional.

Concrete

Specifications	
Collar Tube	0.25" x 2" I.D. ASTM A513, Fy = 65 ksi or Better
End Effector	5" x 5" x 5/8" Steel Bearing Plate
Pile Connection	(1) 7/8" SAE J429 Grade 5 Zinc Coated to ASTM B695/F1941
Coating	Galvanized per ASTM A153/A123 (G), Bare Steel (NG), or Epoxy Coated per ICC-ES AC228 (EP)
Compatibility	MS150B
Capacity	
Ultimate Compression/ Tension	32 Tons / 28 Tons
Allowable Compression/ Tension	16 Tons / 14 Tons

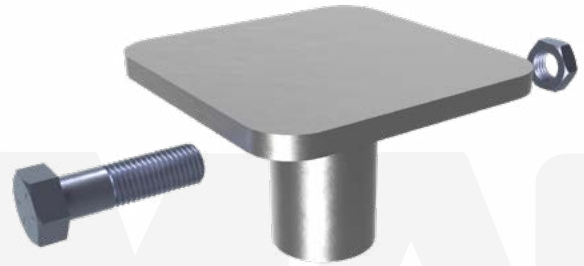

Notes: Cap capacity is developed using the ASD design method and considers strength of collar, end effector, and pile connection. Capacity may be limited by the helical pile, bearing/pullout capacity of soil, or strength of the concrete the cap is embedded in.

Installation Notes: After installation of a MAGNUM® Helical Pile to the correct depth, torque, and capacity, cut-off the pile shaft at the proper elevation. Drill (1) 15/16" diameter hole through the shaft using a MAGNUM® drill template, place the cap over the shaft and secure with (1) 7/8" bolt. Snug tighten nut. Ensure direct bearing of plate on shaft. Place reinforcing steel, cast concrete and consolidate around the pile cap per project requirements.

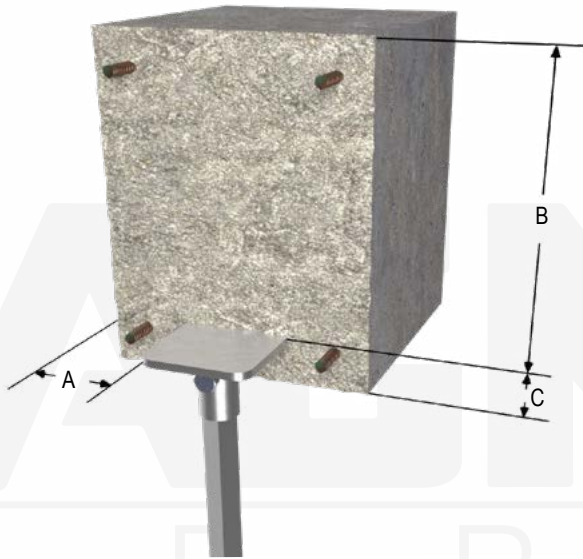

- A - As Required for Shear (Min. 4" per IBC)
- B - As required for Compression. See pages 186-187.
- C - As Required for Tension (Min. 3" per IBC). See pages 186-187.



156 Circle Freeway Dr.
Cincinnati, OH 45246
800-822-7437

www.MagnumPiering.com

MAGNUM® MSC1300-175O6565B Bearing Plate Cap

Allowable Capacity 26 Tons Compression / 18 Tons Tension

6-1/2" x 6-1/2" x 7/8" Bearing Plate & 2.375-Inch I.D. Collar
Fits MS175 Helical Pier

Description: MAGNUM® Bearing Plate Caps consist of a collar tube with bolt hole for connection to MAGNUM® helical piles and steel bearing plate for embedment in cast-in-place concrete. MAGNUM® products are manufactured in the USA according to our ISO 9001 approved quality program. Structural capacities are developed according to AISC 360 and ACI 318 considering an average design life of 75 years for bare steel in most soil conditions. Hot-dip galvanizing is available upon request. Design and detailing of the structure to which the bearing plate cap is embedded in varies by project and is the responsibility of the registered design professional.

Specifications	
Collar Tube	0.25" x 2.375" I.D. ASTM A513, F _y = 65 ksi or Better
End Effector	6-1/2" x 6-1/2" x 7/8" Steel Bearing Plate
Pile Connection	(1) 1" SAE J429 Grade 8 Zinc Coated to ASTM B695/F1941
Coating	Galvanized per ASTM A153/A123 (G), Bare Steel (NG), or Epoxy Coated per ICC-ES AC228 (EP)
Compatibility	MS175B
Capacity	
Ultimate Compression/ Tension	52 Tons / 36 Tons
Allowable Compression/ Tension	26 Tons / 18 Tons

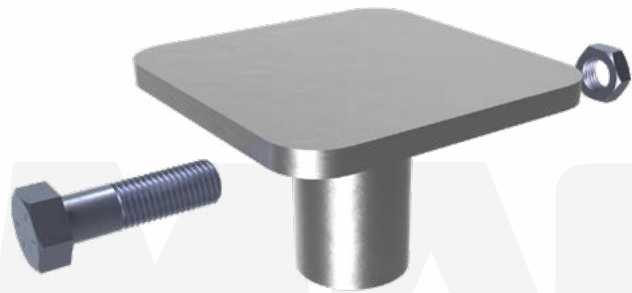

Notes: Cap capacity is developed using the ASD design method and considers strength of collar, end effector, and pile connection. Capacity may be limited by the helical pile, bearing/pullout capacity of soil, or strength of the concrete the cap is embedded in.

Installation Notes: After installation of a MAGNUM® Helical Pile to the correct depth, torque, and capacity, cut-off the pile shaft at the proper elevation. Drill (1) 1-1/16" diameter hole through the shaft using a MAGNUM® drill template, place the cap over the shaft and secure with (1) 1" bolt. Snug tighten nut. Ensure direct bearing of plate on shaft. Place reinforcing steel, cast concrete and consolidate around the pile cap per project requirements.

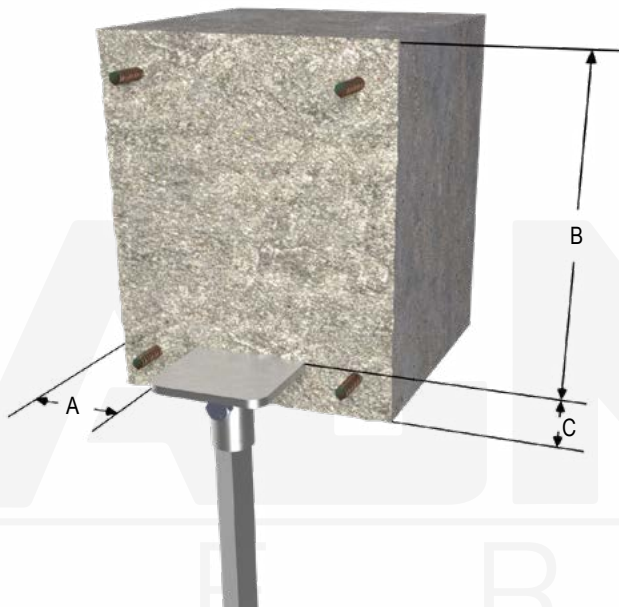

- A - As Required for Shear (Min. 4" per IBC)
- B - As required for Compression. See pages 186-187.
- C - As Required for Tension (Min. 3" per IBC). See pages 186-187.

MAGNUM®
P I E R I N G
designed to support

156 Circle Freeway Dr.
Cincinnati, OH 45246
800-822-7437
www.MagnumPiering.com

MAGNUM® MHC1300-2K55B1 Bearing Plate Cap

Allowable Capacity 13 Tons Compression / 13 Tons Tension

5" x 5" x 3/8" Bearing Plate & 3.0-Inch I.D. Collar
Fits MH222 & MH227 Helical Piles

Description: MAGNUM® Bearing Plate Caps consist of a collar tube with bolt hole for connection to MAGNUM® helical piles and steel bearing plate for embedment in cast-in-place concrete. MAGNUM® products are manufactured in the USA according to our ISO 9001 approved quality program. Structural capacities are developed according to AISC 360 and ACI 318 considering an average design life of 75 years for bare steel in most soil conditions. Hot-dip galvanizing is available upon request. Design and detailing of the structure to which the bearing plate cap is embedded in varies by project and is the responsibility of the registered design professional.

Concrete

Specifications	
Collar Tube	0.25" x 3.0" I.D. ASTM A252, Fy = 80 ksi or Better
End Effector	5" x 5" x 3/8" Steel Bearing Plate
Pile Connection	(1) 3/4" SAE J429 Grade 8 Zinc Coated to ASTM B695/F1941
Coating	Galvanized per ASTM A153/A123 (G), Bare Steel (NG), or Epoxy Coated per ICC-ES AC228 (EP)
Compatibility	MH222, MH227(-6)
Capacity	
Ultimate Compression/ Tension	25 Tons / 25 Tons
Allowable Compression/ Tension	13 Tons / 13 Tons



Notes: Cap capacity is developed using the ASD design method and considers strength of collar, end effector, and pile connection. Capacity may be limited by the helical pile, bearing/pullout capacity of soil, or strength of the concrete the cap is embedded in.

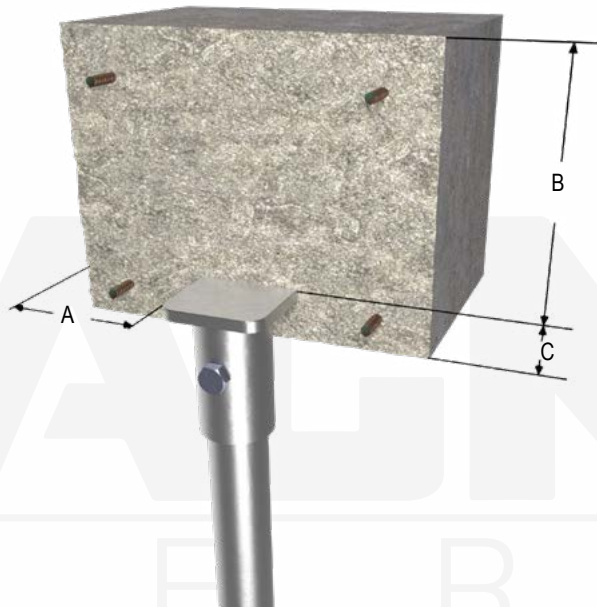

Installation Notes: After installation of a MAGNUM® Helical Pile to the correct depth, torque, and capacity, cut-off the pile shaft at the proper elevation. Drill (1) 13/16" diameter hole through the shaft using a MAGNUM® drill template, place the cap over the shaft and secure with (1) 3/4" bolt. Snug tighten nut(s). Alternatively, drilling through pile may be omitted and plug welds may be used to secure cap to pile in place of bolt(s), see MAGNUM® Technical Bulletin TB004. Ensure direct bearing of plate on shaft. Place reinforcing steel, cast concrete and consolidate around the pile cap per project requirements.

- A - As Required for Shear (Min. 4" per IBC)
- B - As required for Compression. See pages 186-187.
- C - As Required for Tension (Min. 3" per IBC). See pages 186-187.



156 Circle Freeway Dr.
Cincinnati, OH 45246
800-822-7437
www.MagnumPiering.com

MAGNUM® MHC1300-2M66B2 Bearing Plate Cap

Allowable Capacity 21 Tons Compression / 21 Tons Tension

6" x 6" x 5/8" Bearing Plate & 3.0-Inch I.D. Collar
Fits MH222 & MH227 Helical Piles

Description: MAGNUM® Bearing Plate Caps consist of a collar tube with bolt hole for connection to MAGNUM® helical piles and steel bearing plate for embedment in cast-in-place concrete. MAGNUM® products are manufactured in the USA according to our ISO 9001 approved quality program. Structural capacities are developed according to AISC 360 and ACI 318 considering an average design life of 75 years for bare steel in most soil conditions. Hot-dip galvanizing is available upon request. Design and detailing of the structure to which the bearing plate cap is embedded in varies by project and is the responsibility of the registered design professional..

Specifications	
Collar Tube	0.25" x 3.0" I.D. ASTM A252, Fy = 80 ksi or Better
End Effector	6" x 6" x 5/8" Steel Bearing Plate
Pile Connection	(2) 3/4" SAE J429 Grade 8 Zinc Coated to ASTM B695/F1941
Coating	Galvanized per ASTM A153/A123 (G), Bare Steel (NG), or Epoxy Coated per ICC-ES AC228 (EP)
Compatibility	MH222, MH227(-6)
Capacity	
Ultimate Compression/ Tension	42 Tons / 42 Tons
Allowable Compression/ Tension	21 Tons / 21 Tons



Notes: Cap capacity is developed using the ASD design method and considers strength of collar, end effector, and pile connection. Capacity may be limited by the helical pile, bearing/pullout capacity of soil, or strength of the concrete the cap is embedded in.

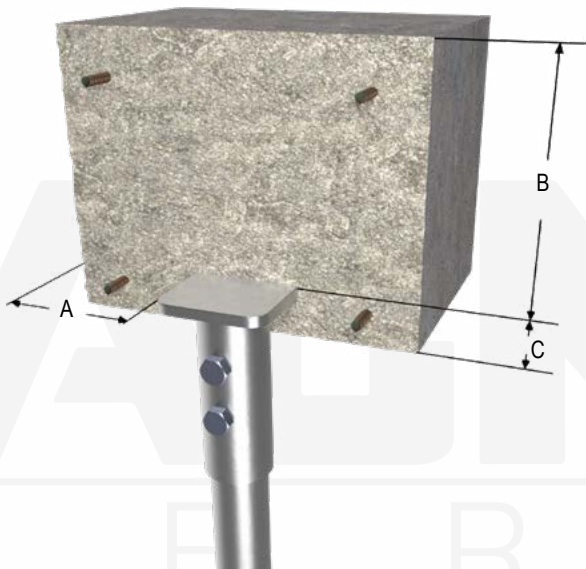

- A - As Required for Shear (Min. 4" per IBC)
- B - As required for Compression. See pages 186-187.
- C - As Required for Tension (Min. 3" per IBC). See pages 186-187.

Installation Notes: After installation of a MAGNUM® Helical Pile to the correct depth, torque, and capacity, cut-off the pile shaft at the proper elevation. Drill (2) 13/16" diameter holes through the shaft using a MAGNUM® drill template, place the cap over the shaft and secure with (2) 3/4" bolt. Snug tighten nut(s). Alternatively, drilling through pile may be omitted and plug welds may be used to secure cap to pile in place of bolt(s), see MAGNUM® Technical Bulletin TB004. Ensure direct bearing of plate on shaft. Place reinforcing steel, cast concrete and consolidate around the pile cap per project requirements.

MAGNUM®
P I E R I N G
designed to support

156 Circle Freeway Dr.
Cincinnati, OH 45246
800-822-7437
www.MagnumPiering.com

MAGNUM® MHC1300-3K55B Bearing Plate Cap

Allowable Capacity 16 Tons Compression / 16 Tons Tension

5" x 5" x 3/8" Bearing Plate & 3.13-Inch I.D. Collar
Fits MH313B, MH313BR & MH325B Helical Piles

Description: MAGNUM® Bearing Plate Caps consist of a collar tube with bolt hole for connection to MAGNUM® helical piles and steel bearing plate for embedment in cast-in-place concrete. MAGNUM® products are manufactured in the USA according to our ISO 9001 approved quality program. Structural capacities are developed according to AISC 360 and ACI 318 considering an average design life of 75 years for bare steel in most soil conditions. Hot-dip galvanizing is available upon request. Design and detailing of the structure to which the bearing plate cap is embedded in varies by project and is the responsibility of the registered design professional.

Concrete

Specifications	
Collar Tube	0.25" x 3.13" I.D. ASTM A513, Fy = 65 ksi or Better
End Effector	5" x 5" x 3/8" Steel Bearing Plate
Pile Connection	(1) 7/8" SAE J429 Grade 5 Zinc Coated to ASTM B695/F1941
Coating	Galvanized per ASTM A153/A123 (G), Bare Steel (NG), or Epoxy Coated per ICC-ES AC228 (EP)
Compatibility	MH313B, MH313BR, MH325B
Capacity	
Ultimate Compression/ Tension	32 Tons / 32 Tons
Allowable Compression/ Tension	16 Tons / 16 Tons

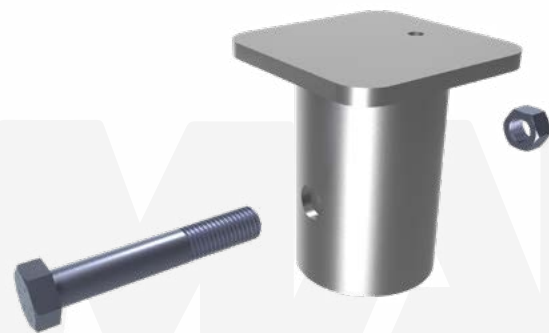

Notes: Cap capacity is developed using the ASD design method and considers strength of collar, end effector, and pile connection. Capacity may be limited by the helical pile, bearing/pullout capacity of soil, or strength of the concrete the cap is embedded in.

Installation Notes: After installation of a MAGNUM® Helical Pile to the correct depth, torque, and capacity, cut-off the pile shaft at the proper elevation. Drill (1) 15/16" diameter hole through the shaft using a MAGNUM® drill template, place the cap over the shaft and secure with (1) 7/8" bolt. Snug tighten nut. Ensure direct bearing of plate on shaft. Place reinforcing steel, cast concrete and consolidate around the pile cap per project requirements.

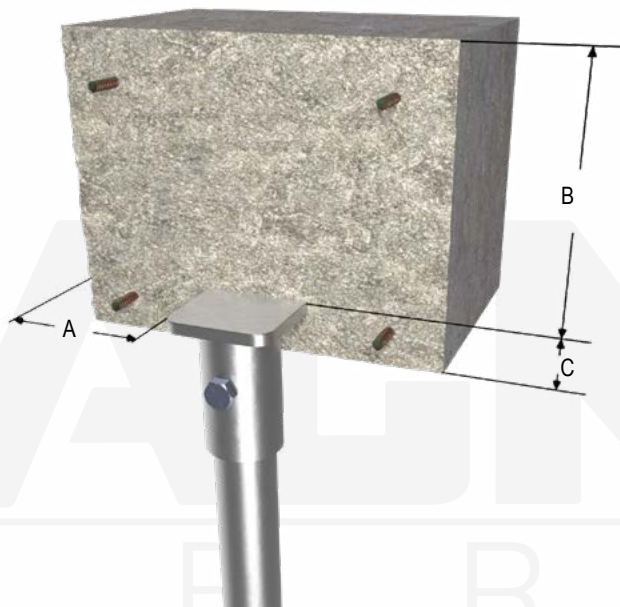

A - As Required for Shear (Min. 4" per IBC)
B - As required for Compression. See pages 186-187.
C - As Required for Tension (Min. 3" per IBC). See pages 186-187.

MAGNUM®
P I E R I N G
designed to support

156 Circle Freeway Dr.
Cincinnati, OH 45246
800-822-7437

www.MagnumPiering.com

MAGNUM® MHC1300-3M6565BR2 Bearing Plate Cap

Allowable Capacity 25 Tons Compression / 25 Tons Tension

6-1/2" x 6-1/2" x 5/8" Bearing Plate & 3.13-Inch I.D. Collar
Fits MH325BR(-6) Helical Piles

Description: MAGNUM® Bearing Plate Caps consist of a collar tube with bolt holes for connection to MAGNUM® helical piles and steel bearing plate for embedment in cast-in-place concrete. MAGNUM® products are manufactured in the USA according to our ISO 9001 approved quality program. Structural capacities are developed according to AISC 360 and ACI 318 considering an average design life of 75 years for bare steel in most soil conditions. Hot-dip galvanizing is available upon request. Design and detailing of the structure to which the bearing plate cap is embedded in varies by project and is the responsibility of the registered design professional.

Specifications	
Collar Tube	0.31" x 3.13" I.D. ASTM A513, Fy = 65 ksi or Better
End Effector	6-1/2" x 6-1/2" x 5/8" Steel Bearing Plate
Pile Connection	(2) 1" SAE J429 Grade 8 Zinc Coated to ASTM B695/F1941
Coating	Galvanized per ASTM A153/A123 (G), Bare Steel (NG), or Epoxy Coated per ICC-ES AC228 (EP)
Compatibility	MH325BR(-6)
Capacity	
Ultimate Compression/ Tension	50 Tons / 50 Tons
Allowable Compression/ Tension	25 Tons / 25 Tons

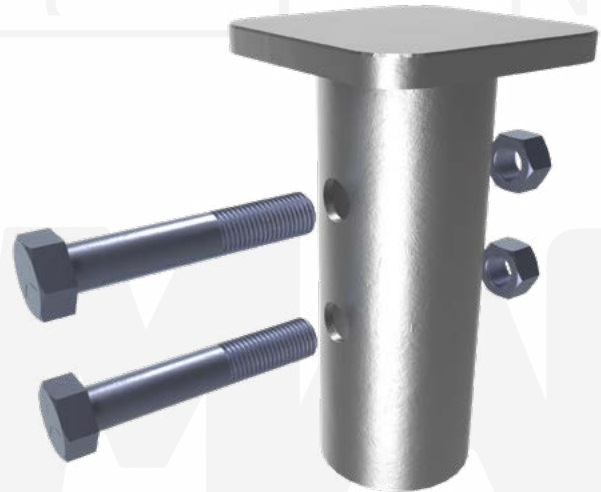

Notes: Cap capacity is developed using the ASD design method and considers strength of collar, end effector, and pile connection. Capacity may be limited by the helical pile, bearing/pullout capacity of soil, or strength of the concrete the cap is embedded in.

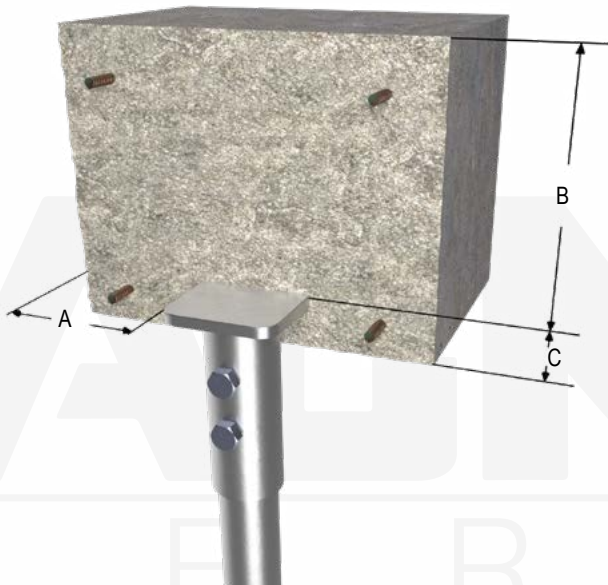

Installation Notes: After installation of a MAGNUM® Helical Pile to the correct depth, torque, and capacity, cut-off the pile shaft at the proper elevation. Drill (2) 1-1/16" diameter holes through the shaft using a MAGNUM® drill template, place the cap over the shaft and secure with (2) 1" bolt. Snug tighten nut(s). Alternatively, drilling through pile may be omitted and plug welds may be used to secure cap to pile in place of bolt(s), see MAGNUM® Technical Bulletin TB004. Ensure direct bearing of plate on shaft. Place reinforcing steel, cast concrete and consolidate around the pile cap per project requirements.

A - As Required for Shear (Min. 4" per IBC)
B - As required for Compression. See pages 186-187.
C - As Required for Tension (Min. 3" per IBC). See pages 186-187.

MAGNUM®
P I E R I N G
designed to support

156 Circle Freeway Dr.
Cincinnati, OH 45246
800-822-7437
www.MagnumPiering.com

MAGNUM® MHC1300-3M66BR1 Bearing Plate Cap

Allowable Capacity 25 Tons Compression / 18 Tons Tension

6" x 6" x 5/8" Bearing Plate & 3.13-Inch I.D. Collar
 Fits MH325BR(-6) Helical Piles

Description: MAGNUM® Bearing Plate Caps consist of a collar tube with bolt hole for connection to MAGNUM® helical piles and steel bearing plate for embedment in cast-in-place concrete. MAGNUM® products are manufactured in the USA according to our ISO 9001 approved quality program. Structural capacities are developed according to AISC 360 and ACI 318 considering an average design life of 75 years for bare steel in most soil conditions. Hot-dip galvanizing is available upon request. Design and detailing of the structure to which the bearing plate cap is embedded in varies by project and is the responsibility of the registered design professional.

Concrete

Specifications	
Collar Tube	0.31" x 3.13" I.D. ASTM A513, Fy = 65 ksi or Better
End Effector	6" x 6" x 5/8" Steel Bearing Plate
Pile Connection	(1) 1" SAE J429 Grade 8 Zinc Coated to ASTM B695/F1941
Coating	Galvanized per ASTM A153/A123 (G), Bare Steel (NG), or Epoxy Coated per ICC-ES AC228 (EP)
Compatibility	MH325BR(-6)
Capacity	
Ultimate Compression/ Tension	50 Tons / 36 Tons
Allowable Compression/ Tension	25 Tons / 18 Tons

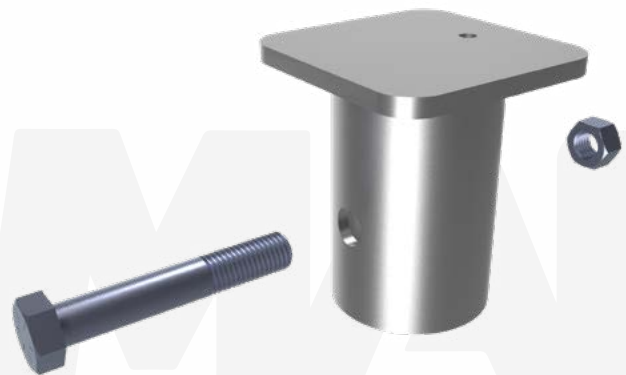

Notes: Cap capacity is developed using the ASD design method and considers strength of collar, end effector, and pile connection. Capacity may be limited by the helical pile, bearing/pullout capacity of soil, or strength of the concrete the cap is embedded in.

Installation Notes: After installation of a MAGNUM® Helical Pile to the correct depth, torque, and capacity, cut-off the pile shaft at the proper elevation. Drill (1) 1-1/16" diameter hole through the shaft using a MAGNUM® drill template, place the cap over the shaft and secure with (1) 1" bolt. Snug tighten nut. Ensure direct bearing of plate on shaft. Place reinforcing steel, cast concrete and consolidate around the pile cap per project requirements.

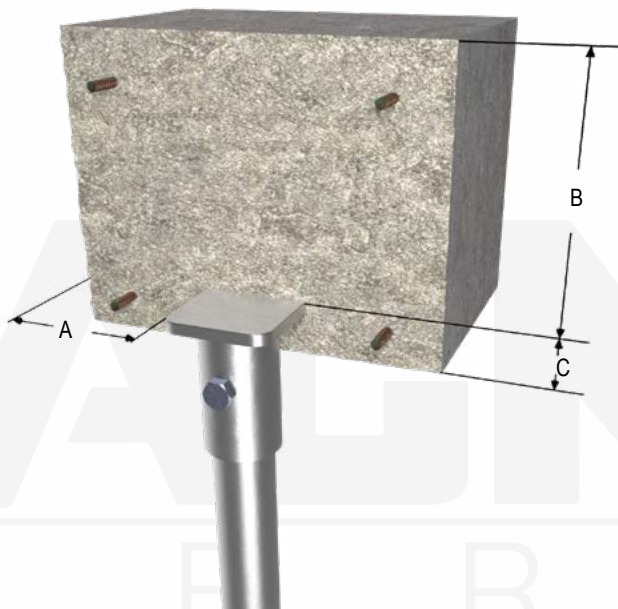

- A - As Required for Shear (Min. 4" per IBC)
- B - As required for Compression. See pages 186-187.
- C - As Required for Tension (Min. 3" per IBC). See pages 186-187.



156 Circle Freeway Dr.
 Cincinnati, OH 45246
 800-822-7437

www.MagnumPiering.com

MAGNUM® MHC1300-35L66B1 Bearing Plate Cap

Allowable Capacity 14 Tons Compression / 11 Tons Tension

6" x 6" x 1/2" Bearing Plate & 3.63-Inch I.D. Collar
Fits MH3521 & MH3530 Helical Piles

Description: MAGNUM® Bearing Plate Caps consist of a collar tube with bolt hole for connection to MAGNUM® helical piles and steel bearing plate for embedment in cast-in-place concrete. MAGNUM® products are manufactured in the USA according to our ISO 9001 approved quality program. Structural capacities are developed according to AISC 360 and ACI 318 considering an average design life of 75 years for bare steel in most soil conditions. Hot-dip galvanizing is available upon request. Design and detailing of the structure to which the bearing plate cap is embedded in varies by project and is the responsibility of the registered design professional.

Specifications	
Collar Tube	0.31" x 3.63" I.D. ASTM A252, Fy = 50 ksi or Better
End Effector	6" x 6" x 1/2" Steel Bearing Plate
Pile Connection	(1) 1" SAE J429 Grade 8 Zinc Coated to ASTM B695/F1941
Coating	Galvanized per ASTM A153/A123 (G), Bare Steel (NG), or Epoxy Coated per ICC-ES AC228 (EP)
Compatibility	MH3521, MH3530
Capacity	
Ultimate Compression/ Tension	28 Tons / 22 Tons
Allowable Compression/ Tension	14 Tons / 11 Tons

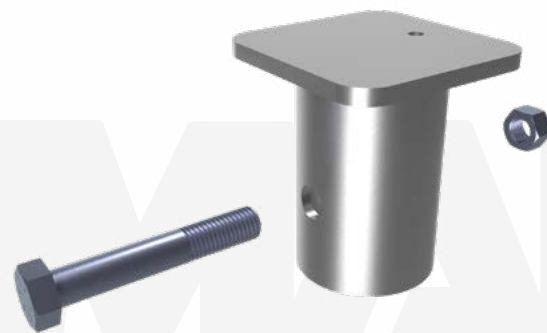

Notes: Cap capacity is developed using the ASD design method and considers strength of collar, end effector, and pile connection. Capacity may be limited by the helical pile, bearing/pullout capacity of soil, or strength of the concrete the cap is embedded in.

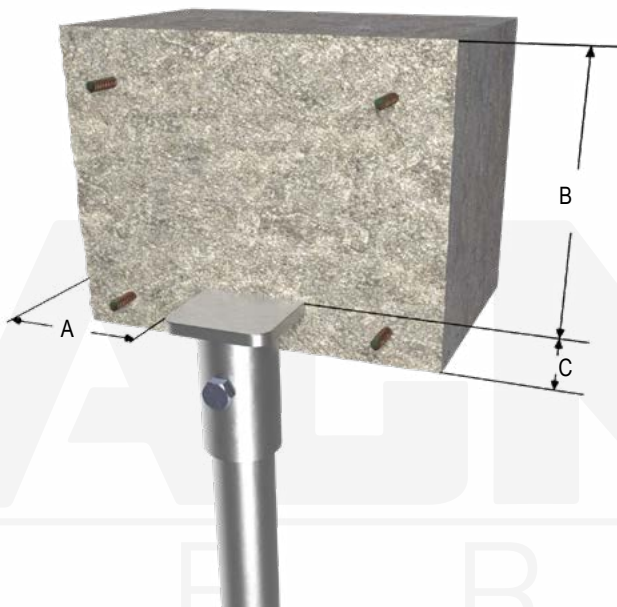

Installation Notes: After installation of a MAGNUM® Helical Pile to the correct depth, torque, and capacity, cut-off the pile shaft at the proper elevation. Drill (1) 1-1/16" diameter hole through the shaft using a MAGNUM® drill template, place the cap over the shaft and secure with (1) 1" bolt. Snug tighten nut. Ensure direct bearing of plate on shaft. Place reinforcing steel, cast concrete and consolidate around the pile cap per project requirements.

- A - As Required for Shear (Min. 4" per IBC)
- B - As required for Compression. See pages 186-187.
- C - As Required for Tension (Min. 3" per IBC). See pages 186-187.



156 Circle Freeway Dr.
Cincinnati, OH 45246
800-822-7437
www.MagnumPiering.com

MAGNUM® MHC1300-35M66B1 Bearing Plate Cap

Allowable Capacity 30 Tons Compression / 18 Tons Tension

6" x 6" x 5/8" Bearing Plate & 3.63-Inch I.D. Collar
Fits MH3521 & MH3530 Helical Piles

Description: MAGNUM® Bearing Plate Caps consist of a collar tube with bolt hole for connection to MAGNUM® helical piles and steel bearing plate for embedment in cast-in-place concrete. MAGNUM® products are manufactured in the USA according to our ISO 9001 approved quality program. Structural capacities are developed according to AISC 360 and ACI 318 considering an average design life of 75 years for bare steel in most soil conditions. Hot-dip galvanizing is available upon request. Design and detailing of the structure to which the bearing plate cap is embedded in varies by project and is the responsibility of the registered design professional.

Concrete

Specifications	
Collar Tube	0.375" x 3.63" I.D. ASTM A252, Fy = 50 ksi or Better
End Effector	6" x 6" x 5/8" Steel Bearing Plate
Pile Connection	(1) 1" SAE J429 Grade 8 Zinc Coated to ASTM B695/F1941
Coating	Galvanized per ASTM A153/A123 (G), Bare Steel (NG), or Epoxy Coated per ICC-ES AC228 (EP)
Compatibility	MH3521, MH3530
Capacity	
Ultimate Compression/ Tension	60 Tons / 36 Tons
Allowable Compression/ Tension	30 Tons / 18 Tons

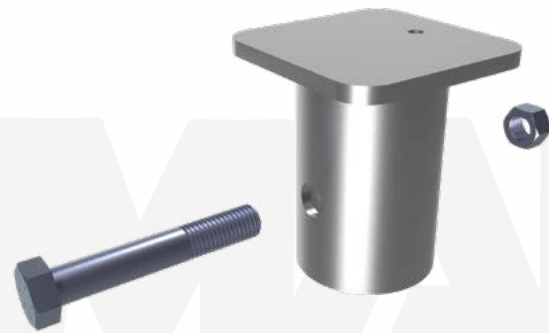

Notes: Cap capacity is developed using the ASD design method and considers strength of collar, end effector, and pile connection. Capacity may be limited by the helical pile, bearing/pullout capacity of soil, or strength of the concrete the cap is embedded in.

Installation Notes: After installation of a MAGNUM® Helical Pile to the correct depth, torque, and capacity, cut-off the pile shaft at the proper elevation. Drill (1) 1-1/16" diameter hole through the shaft using a MAGNUM® drill template, place the cap over the shaft and secure with (1) 1" bolt. Snug tighten nut. Ensure direct bearing of plate on shaft. Place reinforcing steel, cast concrete and consolidate around the pile cap per project requirements.

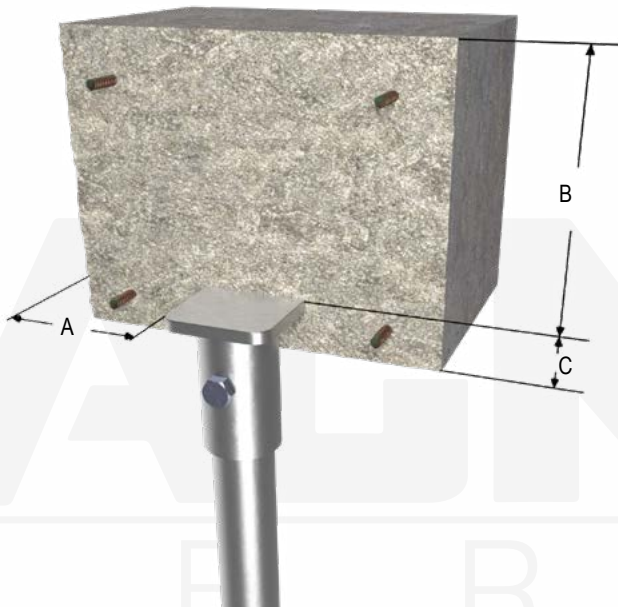

- A - As Required for Shear (Min. 4" per IBC)
- B - As required for Compression. See pages 186-187.
- C - As Required for Tension (Min. 3" per IBC). See pages 186-187.



156 Circle Freeway Dr.
Cincinnati, OH 45246
800-822-7437
www.MagnumPiering.com

MAGNUM® MHC1300-4N88B1 Bearing Plate Cap

Allowable Capacity 38.5 Tons Compression / 23 Tons Tension

8" x 8" x 3/4" Bearing Plate & 4.63-Inch I.D. Collar
Fits MH429 & MH434 Helical Piles

Description: MAGNUM® Bearing Plate Caps consist of a collar tube with bolt hole for connection to MAGNUM® helical piles and steel bearing plate for embedment in cast-in-place concrete. MAGNUM® products are manufactured in the USA according to our ISO 9001 approved quality program. Structural capacities are developed according to AISC 360 and ACI 318 considering an average design life of 75 years for bare steel in most soil conditions. Hot-dip galvanizing is available upon request. Design and detailing of the structure to which the bearing plate cap is embedded in varies by project and is the responsibility of the registered design professional.

Specifications	
Collar Tube	0.31" x 4.63" I.D. ASTM A252, Fy = 65 ksi or Better
End Effector	8" x 8" x 3/4" Steel Bearing Plate
Pile Connection	(1) 1-1/4" SAE J429 Grade 5 Zinc Coated to ASTM B695/F1941
Coating	Galvanized per ASTM A153/A123 (G), Bare Steel (NG), or Epoxy Coated per ICC-ES AC228 (EP)
Compatibility	MH429(-6), MH434(-6)
Capacity	
Ultimate Compression/ Tension	77 Tons / 46 Tons
Allowable Compression/ Tension	38.5 Tons / 23 Tons

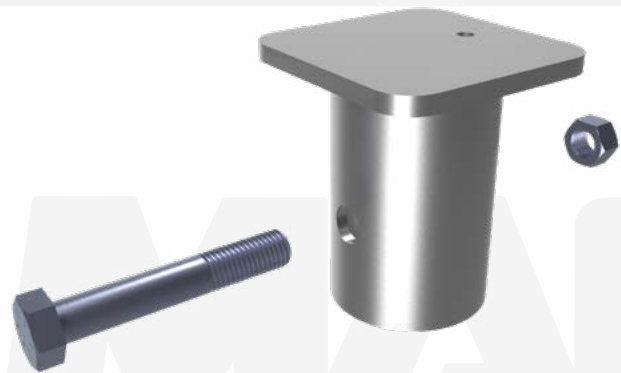

Notes: Cap capacity is developed using the ASD design method and considers strength of collar, end effector, and pile connection. Capacity may be limited by the helical pile, bearing/pullout capacity of soil, or strength of the concrete the cap is embedded in.

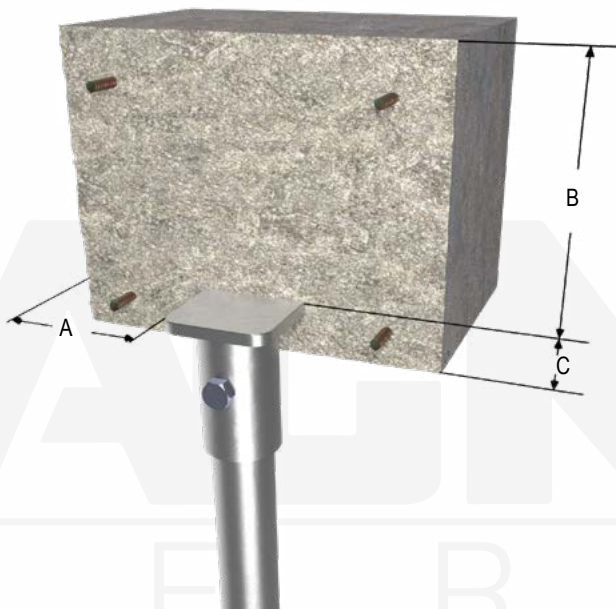

Installation Notes: After installation of a MAGNUM® Helical Pile to the correct depth, torque, and capacity, cut-off the pile shaft at the proper elevation. Drill (1) 1-5/16" diameter hole through the shaft using a MAGNUM® drill template, place the cap over the shaft and secure with (1) 1-1/4" bolt. Snug tighten nut. Ensure direct bearing of plate on shaft. Place reinforcing steel, cast concrete and consolidate around the pile cap per project requirements.

- A - As Required for Shear (Min. 4" per IBC)
- B - As required for Compression. See pages 186-187.
- C - As Required for Tension (Min. 3" per IBC). See pages 186-187.

MAGNUM®
PIERING
designed to support

156 Circle Freeway Dr.
Cincinnati, OH 45246
800-822-7437
www.MagnumPiering.com

MAGNUM® MHC1300-4N88B2 Bearing Plate Cap

Allowable Capacity 46 Tons Compression / 46 Tons Tension

8" x 8" x 3/4" Bearing Plate & 4.63-Inch I.D. Collar
Fits MH429 & MH434 Helical Piles

Description: MAGNUM® Bearing Plate Caps consist of a collar tube with bolt holes for connection to MAGNUM® helical piles and steel bearing plate for embedment in cast-in-place concrete. MAGNUM® products are manufactured in the USA according to our ISO 9001 approved quality program. Structural capacities are developed according to AISC 360 and ACI 318 considering an average design life of 75 years for bare steel in most soil conditions. Hot-dip galvanizing is available upon request. Design and detailing of the structure to which the bearing plate cap is embedded in varies by project and is the responsibility of the registered design professional.

Concrete

Specifications	
Collar Tube	0.31" x 4.63" I.D. ASTM A252, Fy = 65 ksi or Better
End Effector	8" x 8" x 3/4" Steel Bearing Plate
Pile Connection	(2) 1-1/4" SAE J429 Grade 5 Zinc Coated to ASTM B695/F1941
Coating	Galvanized per ASTM A153/A123 (G), Bare Steel (NG), or Epoxy Coated per ICC-ES AC228 (EP)
Compatibility	MH429(-6), MH434(-6)
Capacity	
Ultimate Compression/ Tension	92 Tons / 92 Tons
Allowable Compression/ Tension	46 Tons / 46 Tons



Notes: Cap capacity is developed using the ASD design method and considers strength of collar, end effector, and pile connection. Capacity may be limited by the helical pile, bearing/pullout capacity of soil, or strength of the concrete the cap is embedded in.

Installation Notes: After installation of a MAGNUM® Helical Pile to the correct depth, torque, and capacity, cut-off the pile shaft at the proper elevation. Drill (2) 1-5/16" diameter holes through the shaft using a MAGNUM® drill template, place the cap over the shaft and secure with (2) 1-1/4" bolts. Snug tighten nut. Ensure direct bearing of plate on shaft. Place reinforcing steel, cast concrete and consolidate around the pile cap per project requirements.

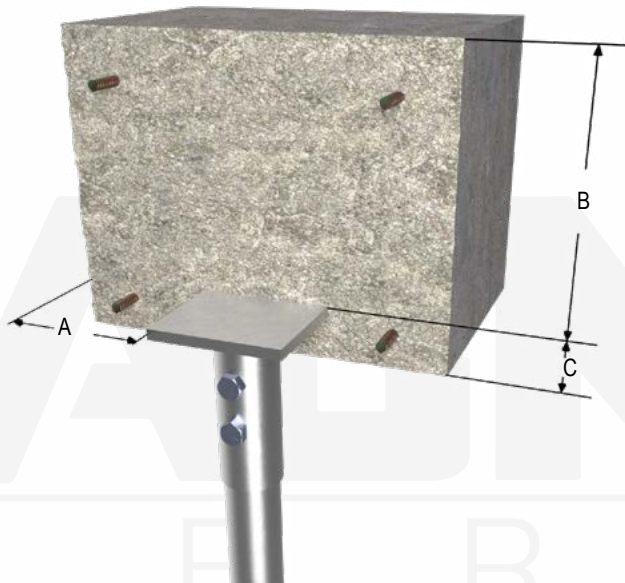

A - As Required for Shear (Min. 4" per IBC)
B - As required for Compression. See pages 186-187.
C - As Required for Tension (Min. 3" per IBC). See pages 186-187.

MAGNUM®
P I E R I N G
designed to support

156 Circle Freeway Dr.
Cincinnati, OH 45246
800-822-7437

www.MagnumPiering.com

MAGNUM® MHC1300-5N18B1 Bearing Plate Cap

Allowable Capacity 23 Tons Compression / 23 Tons Tension

18" Ø x 3/4" Bearing Plate & 5.75-Inch I.D. Collar
Fits MH530, MH536, MH542 & MH547 Helical Piles

Description: MAGNUM® Bearing Plate Caps consist of a collar tube with bolt hole for connection to MAGNUM® helical piles and steel bearing plate for embedment in cast-in-place concrete. MAGNUM® products are manufactured in the USA according to our ISO 9001 approved quality program. Structural capacities are developed according to AISC 360 and ACI 318 considering an average design life of 75 years for bare steel in most soil conditions. Hot-dip galvanizing is available upon request. Design and detailing of the structure to which the bearing plate cap is embedded in varies by project and is the responsibility of the registered design professional.

Specifications	
Collar Tube	0.44" x 5.75" I.D. ASTM A252, Fy = 70 ksi or Better
End Effector	18" Ø x 3/4" Steel Bearing Plate
Pile Connection	((1) 1-1/2" SAE J429 Grade 5 Zinc Coated to ASTM B695/F1941
Coating	Galvanized per ASTM A153/A123 (G), Bare Steel (NG), or Epoxy Coated per ICC-ES AC228 (EP)
Compatibility	MH530-6, MH536-6, MH542-6, MH547-6
Capacity	
Ultimate Compression/Tension	46 Tons / 46 Tons
Allowable Compression/Tension	23 Tons / 23 Tons

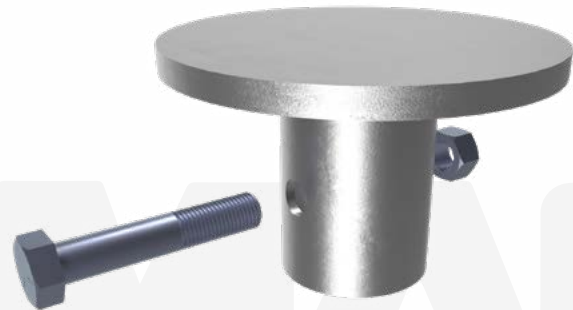

Notes: Cap capacity is developed using the ASD design method and considers strength of collar, end effector, and pile connection. Capacity may be limited by the helical pile, bearing/pullout capacity of soil, or strength of the concrete the cap is embedded in.

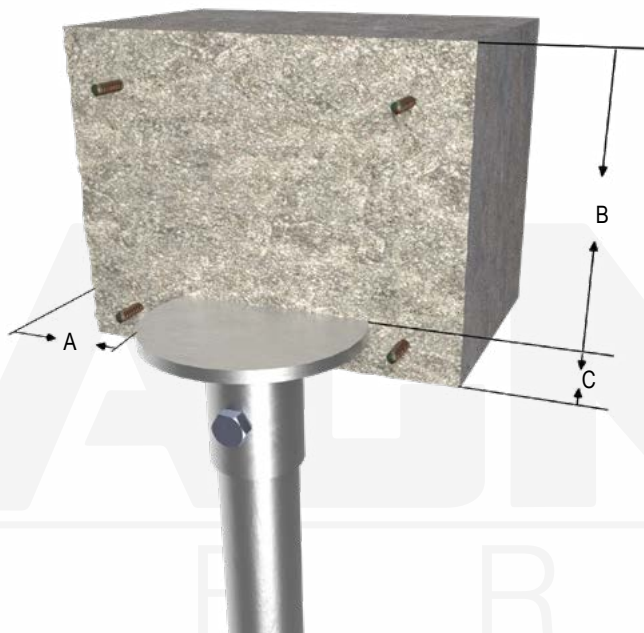

Installation Notes: After installation of a MAGNUM® Helical Pile to the correct depth, torque, and capacity, cut-off the pile shaft at the proper elevation. Drill (1) 1-9/16" diameter hole through the shaft using a MAGNUM® drill template, place the cap over the shaft and secure with (1) 1-1/2" bolt. Snug tighten nut. Ensure direct bearing of plate on shaft. Place reinforcing steel, cast concrete and consolidate around the pile cap per project requirements.

A - As Required for Shear (Min. 4" per IBC)
B - As required for Compression. See pages 186-187.
C - As Required for Tension (Min. 3" per IBC). See pages 186-187.

MAGNUM®
P I E R I N G
designed to support

156 Circle Freeway Dr.
Cincinnati, OH 45246
800-822-7437
www.MagnumPiering.com

MAGNUM® MHC1300-5O99B1 Bearing Plate Cap

Allowable Capacity 68 Tons Compression / 39 Tons Tension

9" x 9" x 7/8" Bearing Plate & 5.75-Inch I.D. Collar
Fits MH530, MH536, MH542 & MH547 Helical Piles

Description: MAGNUM® Bearing Plate Caps consist of a collar tube with bolt hole for connection to MAGNUM® helical piles and steel bearing plate for embedment in cast-in-place concrete. MAGNUM® products are manufactured in the USA according to our ISO 9001 approved quality program. Structural capacities are developed according to AISC 360 and ACI 318 considering an average design life of 75 years for bare steel in most soil conditions. Hot-dip galvanizing is available upon request. Design and detailing of the structure to which the bearing plate cap is embedded in varies by project and is the responsibility of the registered design professional.

Concrete

Specifications	
Collar Tube	0.44" x 5.75" I.D. ASTM A252, Fy = 70 ksi or Better
End Effector	9" x 9" x 7/8" Steel Bearing Plate
Pile Connection	(1) 1-1/2" SAE J429 Grade 5 Zinc Coated to ASTM B695/F1941
Coating	Galvanized per ASTM A153/A123 (G), Bare Steel (NG), or Epoxy Coated per ICC-ES AC228 (EP)
Compatibility	MH530-6, MH536-6, MH542-6, MH547-6
Capacity	
Ultimate Compression/ Tension	136 Tons / 78 Tons
Allowable Compression/ Tension	68 Tons / 39 Tons

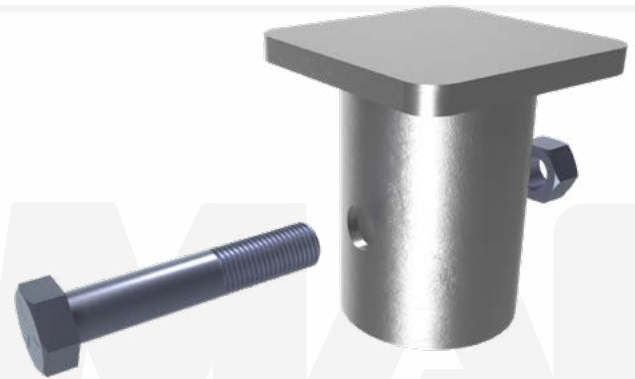

Notes: Cap capacity is developed using the ASD design method and considers strength of collar, end effector, and pile connection. Capacity may be limited by the helical pile, bearing/pullout capacity of soil, or strength of the concrete the cap is embedded in.

Installation Notes: After installation of a MAGNUM® Helical Pile to the correct depth, torque, and capacity, cut-off the pile shaft at the proper elevation. Drill (1) 1-9/16" diameter hole through the shaft using a MAGNUM® drill template, place the cap over the shaft and secure with (1) 1-1/2" bolt. Snug tighten nut. Ensure direct bearing of plate on shaft. Place reinforcing steel, cast concrete and consolidate around the pile cap per project requirements.

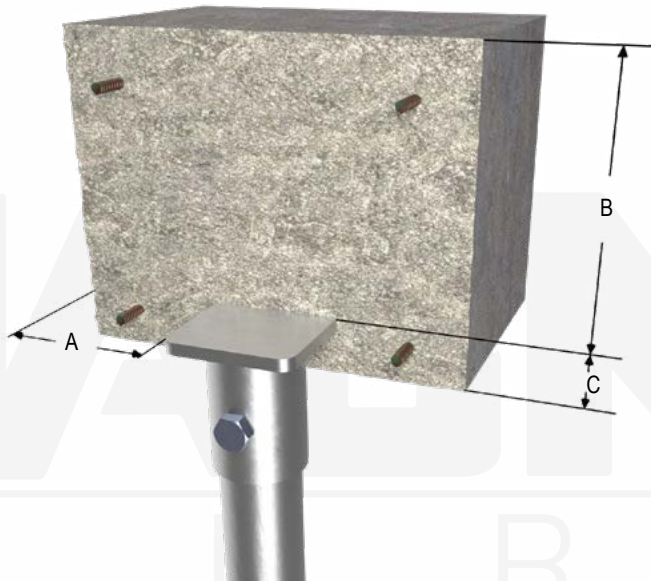

- A - As Required for Shear (Min. 4" per IBC)
- B - As required for Compression. See pages 186-187.
- C - As Required for Tension (Min. 3" per IBC). See pages 186-187.



156 Circle Freeway Dr.
Cincinnati, OH 45246
800-822-7437
www.MagnumPiering.com

MAGNUM® MHC1300-5O99B3 Bearing Plate Cap

Allowable Capacity 70 Tons Compression / 70 Tons Tension

9" x 9" x 7/8" Bearing Plate & 5.75-Inch I.D. Collar
 Fits MH530, MH536, MH542 & MH547 Helical Piles

Description: MAGNUM® Bearing Plate Caps consist of a collar tube with bolt holes for connection to MAGNUM® helical piles and steel bearing plate for embedment in cast-in-place concrete. MAGNUM® products are manufactured in the USA according to our ISO 9001 approved quality program. Structural capacities are developed according to AISC 360 and ACI 318 considering an average design life of 75 years for bare steel in most soil conditions. Hot-dip galvanizing is available upon request. Design and detailing of the structure to which the bearing plate cap is embedded in varies by project and is the responsibility of the registered design professional.

Specifications	
Collar Tube	0.44" x 5.75" I.D. ASTM A252, Fy = 70 ksi or Better
End Effector	9" x 9" x 7/8" Steel Bearing Plate
Pile Connection	(3) 1-1/2" SAE J429 Grade 5 Zinc Coated to ASTM B695/F1941
Coating	Galvanized per ASTM A153/A123 (G), Bare Steel (NG), or Epoxy Coated per ICC-ES AC228 (EP)
Compatibility	MH530-6, MH536-6, MH542-6, MH547-6
Capacity	
Ultimate Compression/ Tension	140 Tons / 140 Tons
Allowable Compression/ Tension	70 Tons / 70 Tons



Notes: Cap capacity is developed using the ASD design method and considers strength of collar, end effector, and pile connection. Capacity may be limited by the helical pile, bearing/pullout capacity of soil, or strength of the concrete the cap is embedded in.

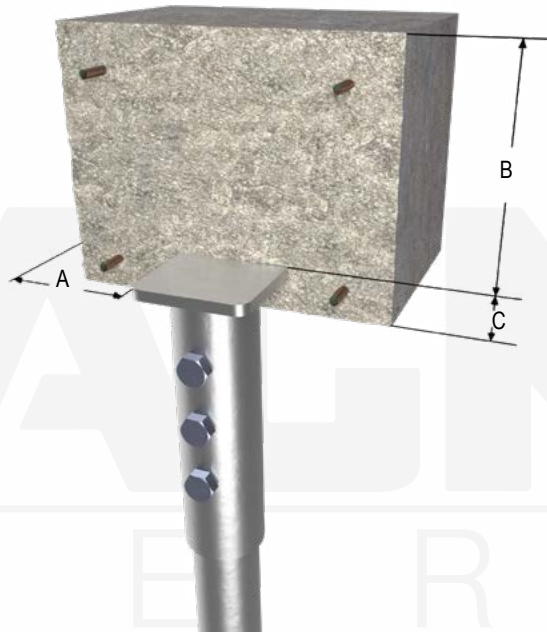

Installation Notes: After installation of a MAGNUM® Helical Pile to the correct depth, torque, and capacity, cut-off the pile shaft at the proper elevation. Drill (3) 1-9/16" diameter holes through the shaft using a MAGNUM® drill template, place the cap over the shaft and secure with (3) 1-1/2" bolts. Snug tighten nut. Ensure direct bearing of plate on shaft. Place reinforcing steel, cast concrete and consolidate around the pile cap per project requirements.

A - As Required for Shear (Min. 4" per IBC)
 B - As required for Compression. See pages 186-187.
 C - As Required for Tension (Min. 3" per IBC). See pages 186-187.

MAGNUM®
 P I E R I N G
 designed to support

156 Circle Freeway Dr.
 Cincinnati, OH 45246
 800-822-7437
www.MagnumPiering.com

MAGNUM® MHC1300-5R1111B1 Bearing Plate Cap

Allowable Capacity 116 Tons Compression / 29 Tons Tension

11" x 11" x 1-1/4" Bearing Plate & 5.75-Inch I.D. Collar
 Fits MH530, MH536, MH542 & MH547 Helical Piles

Description: MAGNUM® Bearing Plate Caps consist of a collar tube with bolt hole for connection to MAGNUM® helical piles and steel bearing plate for embedment in cast-in-place concrete. MAGNUM® products are manufactured in the USA according to our ISO 9001 approved quality program. Structural capacities are developed according to AISC 360 and ACI 318 considering an average design life of 75 years for bare steel in most soil conditions. Hot-dip galvanizing is available upon request. Design and detailing of the structure to which the bearing plate cap is embedded in varies by project and is the responsibility of the registered design professional.

Concrete

Specifications	
Collar Tube	0.44" x 5.75" I.D. ASTM A252, Fy = 70 ksi or Better
End Effector	11" x 11" x 1-1/4" Steel Bearing Plate
Pile Connection	(1) 1-1/2" SAE J429 Grade 5 Zinc Coated to ASTM B695/F1941
Coating	Galvanized per ASTM A153/A123 (G), Bare Steel (NG), or Epoxy Coated per ICC-ES AC228 (EP)
Compatibility	MH530-6, MH536-6, MH542-6, MH547-6
Capacity	
Ultimate Compression/ Tension	232 Tons / 58 Tons
Allowable Compression/ Tension	116 Tons / 29 Tons

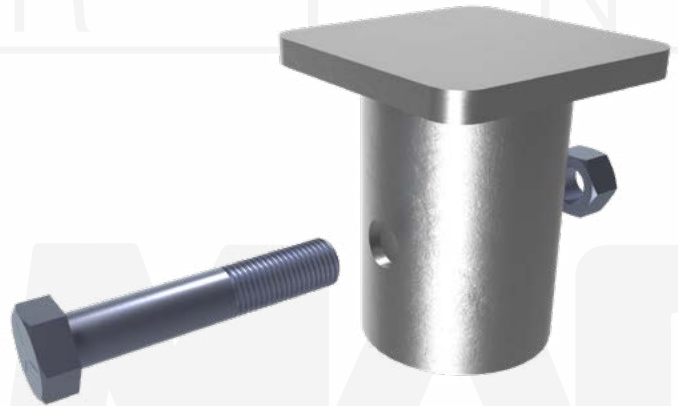

Notes: Cap capacity is developed using the ASD design method and considers strength of collar, end effector, and pile connection. Capacity may be limited by the helical pile, bearing/pullout capacity of soil, or strength of the concrete the cap is embedded in.

Installation Notes: After installation of a MAGNUM® Helical Pile to the correct depth, torque, and capacity, cut-off the pile shaft at the proper elevation. Drill (1) 1-9/16" diameter hole through the shaft using a MAGNUM® drill template, place the cap over the shaft and secure with (1) 1-1/2" bolt. Snug tighten nut. Ensure direct bearing of plate on shaft. Place reinforcing steel, cast concrete and consolidate around the pile cap per project requirements.

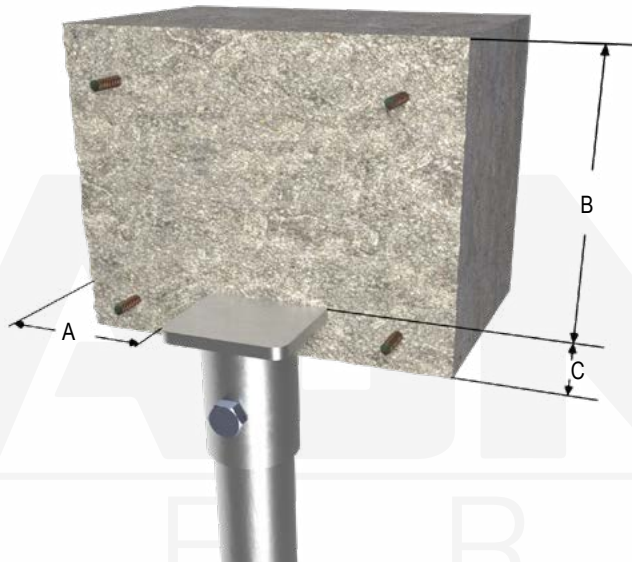

- A - As Required for Shear (Min. 4" per IBC)
- B - As required for Compression. See pages 186-187.
- C - As Required for Tension (Min. 3" per IBC). See pages 186-187.



156 Circle Freeway Dr.
 Cincinnati, OH 45246
 800-822-7437
www.MagnumPiering.com

MAGNUM® MHC1300-5R1111B3 Bearing Plate Cap

Allowable Capacity 116 Tons Compression / 80 Tons Tension

11" x 11" x 1-1/4" Bearing Plate & 5.75-Inch I.D. Collar
 Fits MH530, MH536, MH542 & MH547 Helical Piles

Description: MAGNUM® Bearing Plate Caps consist of a collar tube with bolt holes for connection to MAGNUM® helical piles and steel bearing plate for embedment in cast-in-place concrete. MAGNUM® products are manufactured in the USA according to our ISO 9001 approved quality program. Structural capacities are developed according to AISC 360 and ACI 318 considering an average design life of 75 years for bare steel in most soil conditions. Hot-dip galvanizing is available upon request. Design and detailing of the structure to which the bearing plate cap is embedded in varies by project and is the responsibility of the registered design professional.

Specifications	
Collar Tube	0.44" x 5.75" I.D. ASTM A252, Fy = 70 ksi or Better
End Effector	11" x 11" x 1-1/4" Steel Bearing Plate
Pile Connection	(3) 1-1/2" SAE J429 Grade 5 Zinc Coated to ASTM B695/F1941
Coating	Galvanized per ASTM A153/A123 (G), Bare Steel (NG), or Epoxy Coated per ICC-ES AC228 (EP)
Compatibility	MH530-6, MH536-6, MH542-6, MH547-6
Capacity	
Ultimate Compression/ Tension	232 Tons / 160 Tons
Allowable Compression/ Tension	116 Tons / 80 Tons



Notes: Cap capacity is developed using the ASD design method and considers strength of collar, end effector, and pile connection. Capacity may be limited by the helical pile, bearing/pullout capacity of soil, or strength of the concrete the cap is embedded in.

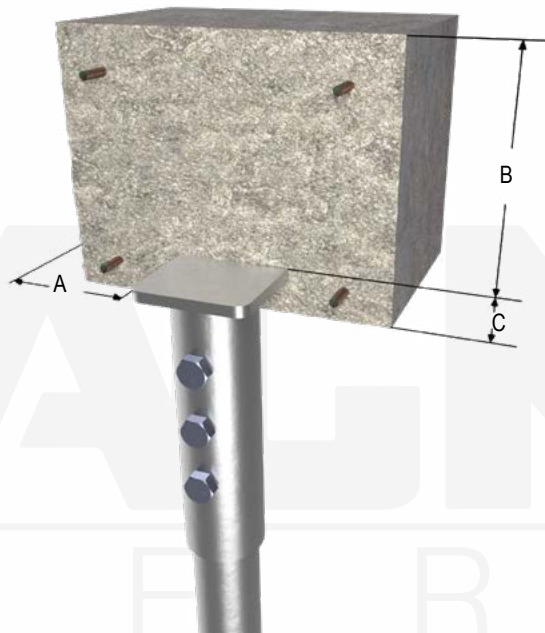

Installation Notes: After installation of a MAGNUM® Helical Pile to the correct depth, torque, and capacity, cut-off the pile shaft at the proper elevation. Drill (3) 1-9/16" diameter holes through the shaft using a MAGNUM® drill template, place the cap over the shaft and secure with (3) 1-1/2" bolts. Snug tighten nut. Ensure direct bearing of plate on shaft. Place reinforcing steel, cast concrete and consolidate around the pile cap per project requirements.

A - As Required for Shear (Min. 4" per IBC)
 B - As required for Compression. See pages 186-187.
 C - As Required for Tension (Min. 3" per IBC). See pages 186-187.



156 Circle Freeway Dr.
 Cincinnati, OH 45246
 800-822-7437
www.MagnumPiering.com

MAGNUM® MHC1300-7O1111B1 Bearing Plate Cap

Allowable Capacity 82 Tons Compression / 39 Tons Tension

11" x 11" x 7/8" Bearing Plate & 7.25-Inch I.D. Collar

Fits MH736-6, MH740-6 & MH745-6 Helical Screw Piles

Description: MAGNUM® Bearing Plate Caps consist of a collar tube with bolt hole for connection to MAGNUM® helical screw piles and steel bearing plate for embedment in cast-in-place concrete. MAGNUM® products are manufactured in the USA according to our ISO 9001 approved quality program. Structural capacities are developed according to AISC 360 and ACI 318 considering an average design life of 75 years for bare steel in most soil conditions. Hot-dip galvanizing is available upon request. Design and detailing of the structure to which the bearing plate cap is embedded in varies by project and is the responsibility of the registered design professional.

Concrete

Specifications	
Collar Tube	0.375" x 7.25" I.D. ASTM A252, Fy = 65 ksi or Better
End Effector	11" x 11" x 7/8" Steel Bearing Plate
Pile Connection	(1) 1-1/2" ASTM A193 B7 Zinc Coated to ASTM B695/F194
Coating	Galvanized per ASTM A153/A123 (G), Bare Steel (NG), or Epoxy Coated per ICC-ES AC228 (EP)
Compatibility	MH736-6, MH740-6, MH745-6
Capacity	
Ultimate Compression/ Tension	164 Tons / 78 Tons
Allowable Compression/ Tension	82 Tons / 39 Tons

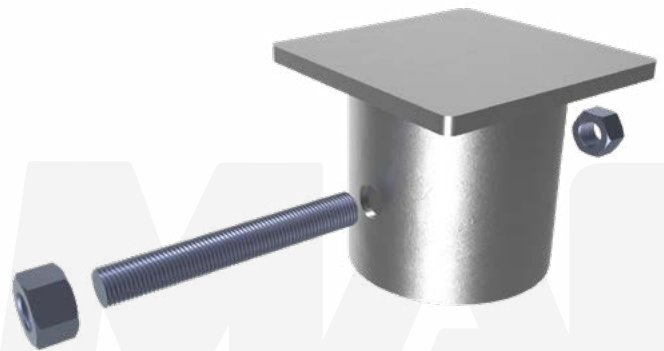

Notes: Cap capacity is developed using the ASD design method and considers strength of collar, end effector, and pile connection. Capacity may be limited by the helical pile, bearing/pullout capacity of soil, or strength of the concrete the cap is embedded in.

Installation Notes: After installation of a MAGNUM® Helical Pile to the correct depth, torque, and capacity, cut-off the pile shaft at the proper elevation. Drill (1) 1-9/16" diameter hole through the shaft using a MAGNUM® drill template, place the cap over the shaft and secure with (1) 1-1/2" bolt. Snug tighten nut. Ensure direct bearing of plate on shaft. Place reinforcing steel, cast concrete and consolidate around the pile cap per project requirements.



- A - As Required for Shear (Min. 4" per IBC)
- B - As required for Compression. See pages 186-187.
- C - As Required for Tension (Min. 3" per IBC). See pages 186-187.



156 Circle Freeway Dr.
Cincinnati, OH 45246
800-822-7437

www.MagnumPiering.com

MAGNUM® MHC1300-8N1212B2 Bearing Plate Cap

Allowable Capacity 80 Tons Compression / 30 Tons Tension

12" x 12" x 3/4" Bearing Plate & 8.835-Inch I.D. Collar
Fits MH832 & MH850 Helical Screw Piles

Description: MAGNUM® Bearing Plate Caps consist of a collar tube with bolt holes for connection to MAGNUM® helical screw piles and steel bearing plate for embedment in cast-in-place concrete. MAGNUM® products are manufactured in the USA according to our ISO 9001 approved quality program. Structural capacities are developed according to AISC 360 and ACI 318 considering an average design life of 75 years for bare steel in most soil conditions. Hot-dip galvanizing is available upon request. Design and detailing of the structure to which the bearing plate cap is embedded in varies by project and is the responsibility of the registered design professional.

Specifications	
Collar Tube	0.395" x 8.835" I.D. ASTM A252, Fy = 50 ksi or Better
End Effector	12" x 12" x 3/4" Steel Bearing Plate
Pile Connection	(2) 1-1/2" ASTM A193 B7 Zinc Coated to ASTM B695/F194
Coating	Galvanized per ASTM A153/A123 (G), Bare Steel (NG), or Epoxy Coated per ICC-ES AC228 (EP)
Compatibility	MH832-6, MH850-6
Capacity	
Ultimate Compression/ Tension	160 Tons / 60 Tons
Allowable Compression/ Tension	80 Tons / 30 Tons



Notes: Cap capacity is developed using the ASD design method and considers strength of collar, end effector, and pile connection. Capacity may be limited by the helical pile, bearing/pullout capacity of soil, or strength of the concrete the cap is embedded in.

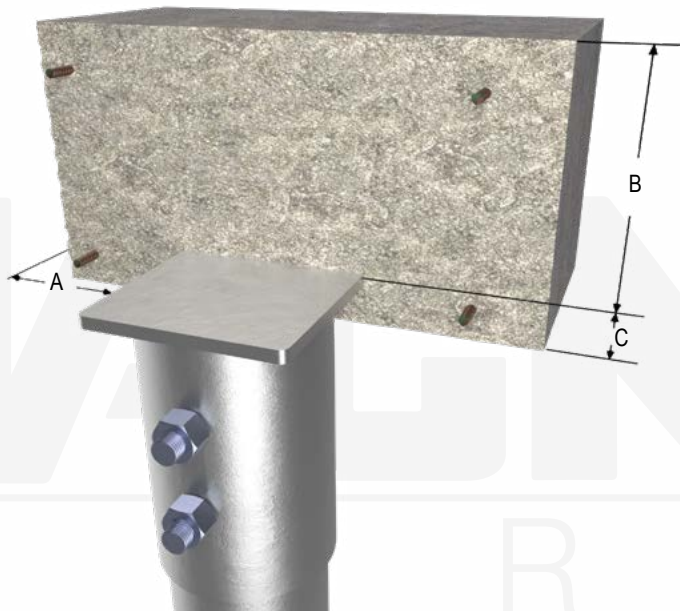

Installation Notes: After installation of a MAGNUM® Helical Pile to the correct depth, torque, and capacity, cut-off the pile shaft at the proper elevation. Drill (2) 1-9/16" diameter holes through the shaft using a MAGNUM® drill template, place the cap over the shaft and secure with (2) 1-1/2" bolts. Snug tighten nut. Ensure direct bearing of plate on shaft. Place reinforcing steel, cast concrete and consolidate around the pile cap per project requirements.

- A - As Required for Shear (Min. 4" per IBC)
- B - As required for Compression. See pages 186-187.
- C - As Required for Tension (Min. 3" per IBC). See pages 186-187.

MAGNUM
PIERING
designed to support

156 Circle Freeway Dr.
Cincinnati, OH 45246
800-822-7437
www.MagnumPiering.com

MAGNUM® MHC1300-9O1313B1 Bearing Plate Cap

Allowable Capacity 140 Tons Compression / 45 Tons Tension

13" x 13" x 7/8" Bearing Plate & 9.85-Inch I.D. Collar
Fits MH939 Helical Screw Piles

Description: MAGNUM® Bearing Plate Caps consist of a collar tube with bolt hole for connection to MAGNUM® helical screw piles and steel bearing plate for embedment in cast-in-place concrete. MAGNUM® products are manufactured in the USA according to our ISO 9001 approved quality program. Structural capacities are developed according to AISC 360 and ACI 318 considering an average design life of 75 years for bare steel in most soil conditions. Hot-dip galvanizing is available upon request. Design and detailing of the structure to which the bearing plate cap is embedded in varies by project and is the responsibility of the registered design professional.

Concrete

Specifications	
Collar Tube	0.45" x 9.85" I.D. ASTM A252, Fy = 65 ksi or Better
End Effector	13" x 13" x 7/8" Steel Bearing Plate
Pile Connection	(1) 1-1/2" ASTM A193 B7 Zinc Coated to ASTM B695/F194
Coating	Galvanized per ASTM A153/A123 (G), Bare Steel (NG), or Epoxy Coated per ICC-ES AC228 (EP)
Compatibility	MH939-6
Capacity	
Ultimate Compression/ Tension	280 Tons / 90 Tons
Allowable Compression/ Tension	140 Tons / 45 Tons

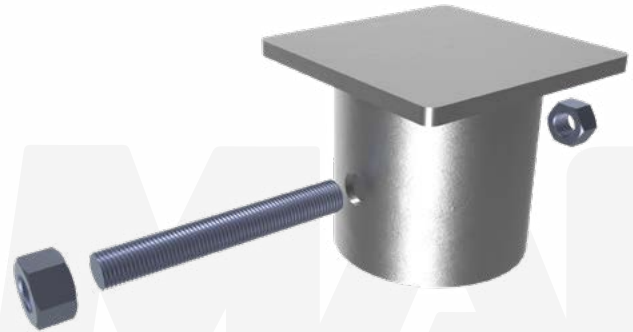

Notes: Cap capacity is developed using the ASD design method and considers strength of collar, end effector, and pile connection. Capacity may be limited by the helical pile, bearing/pullout capacity of soil, or strength of the concrete the cap is embedded in.

Installation Notes: After installation of a MAGNUM® Helical Pile to the correct depth, torque, and capacity, cut-off the pile shaft at the proper elevation. Drill (1) 1-9/16" diameter hole through the shaft using a MAGNUM® drill template, place the cap over the shaft and secure with (1) 1-1/2" bolt. Snug tighten nut. Ensure direct bearing of plate on shaft. Place reinforcing steel, cast concrete and consolidate around the pile cap per project requirements.

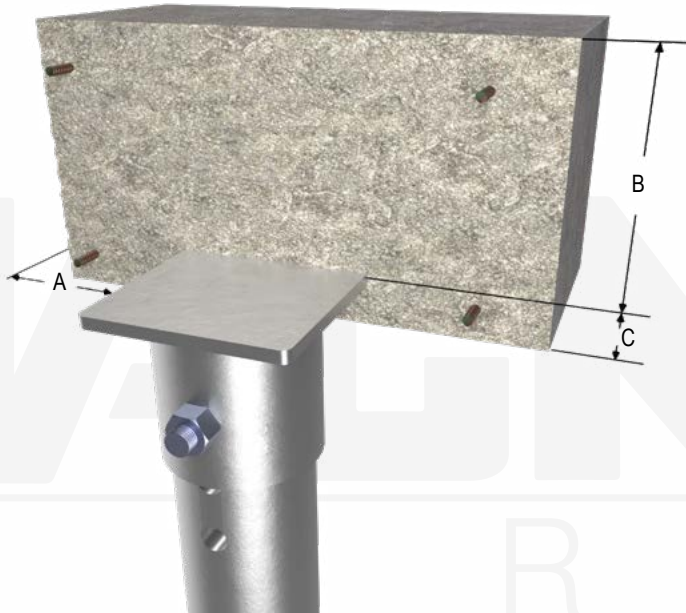

A - As Required for Shear (Min. 4" per IBC)
B - As required for Compression. See pages 186-187.
C - As Required for Tension (Min. 3" per IBC). See pages 186-187.

MAGNUM
PIERING
designed to support

156 Circle Freeway Dr.
Cincinnati, OH 45246
800-822-7437
www.MagnumPiering.com

MAGNUM® MHC1300-9O1313B3 Bearing Plate Cap

Allowable Capacity 140 Tons Compression / 107 Tons Tension

13" x 13" x 7/8" Bearing Plate & 9.85-Inch I.D. Collar

Fits MH939 Helical Screw Piles

Description: MAGNUM® Bearing Plate Caps consist of a collar tube with bolt holes for connection to MAGNUM® helical screw piles and steel bearing plate for embedment in cast-in-place concrete. MAGNUM® products are manufactured in the USA according to our ISO 9001 approved quality program. Structural capacities are developed according to AISC 360 and ACI 318 considering an average design life of 75 years for bare steel in most soil conditions. Hot-dip galvanizing is available upon request. Design and detailing of the structure to which the bearing plate cap is embedded in varies by project and is the responsibility of the registered design professional.

Specifications	
Collar Tube	0.45" x 9.85" I.D. ASTM A252, Fy = 65 ksi or Better
End Effector	13" x 13" x 7/8" Steel Bearing Plate
Pile Connection	(3) 1-1/2" ASTM A193 B7 Zinc Coated to ASTM B695/F194
Coating	Galvanized per ASTM A153/A123 (G), Bare Steel (NG), or Epoxy Coated per ICC-ES AC228 (EP)
Compatibility	MH939-6
Capacity	
Ultimate Compression/ Tension	280 Tons / 214 Tons
Allowable Compression/ Tension	140 Tons / 107 Tons

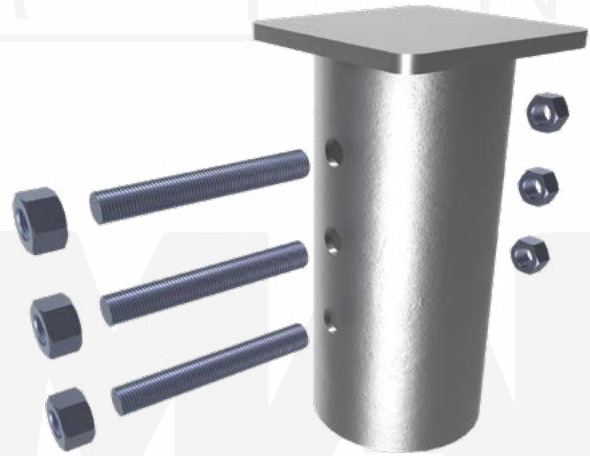

Notes: Cap capacity is developed using the ASD design method and considers strength of collar, end effector, and pile connection. Capacity may be limited by the helical pile, bearing/pullout capacity of soil, or strength of the concrete the cap is embedded in.

Installation Notes: After installation of a MAGNUM® Helical Pile to the correct depth, torque, and capacity, cut-off the pile shaft at the proper elevation. Drill (3) 1-9/16" diameter holes through the shaft using a MAGNUM® drill template, place the cap over the shaft and secure with (3) 1-1/2" bolts. Snug tighten nut. Ensure direct bearing of plate on shaft. Place reinforcing steel, cast concrete and consolidate around the pile cap per project requirements.

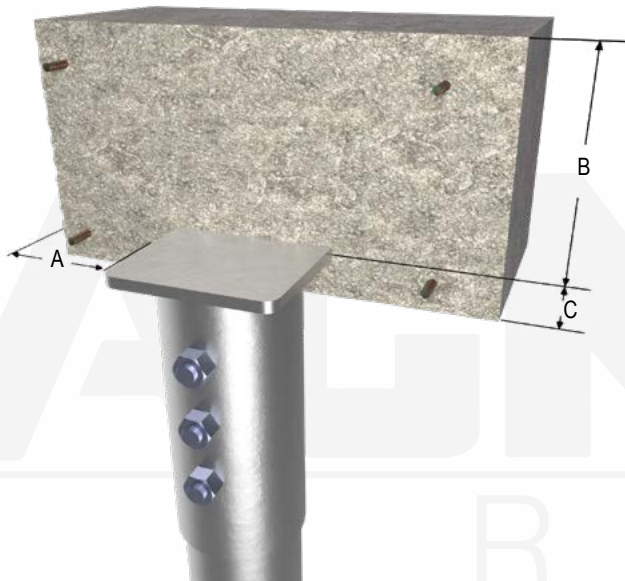

- A - As Required for Shear (Min. 4" per IBC)
- B - As required for Compression. See pages 186-187.
- C - As Required for Tension (Min. 3" per IBC). See pages 186-187.

MAGNUM®
P I E R I N G
designed to support

156 Circle Freeway Dr.
Cincinnati, OH 45246
800-822-7437
www.MagnumPiering.com

MAGNUM® MHC1300-12N25B2 Bearing Plate Cap

Allowable Capacity 27 Tons Compression / 27 Tons Tension

25" Ø X 3/4" Bearing Plate & 13.0-Inch I.D. Collar
Fits MH1250 Helical Screw Piles

Description: MAGNUM® Bearing Plate Caps consist of a collar tube with bolt holes for connection to MAGNUM® helical screw piles and steel bearing plate for embedment in cast-in-place concrete. MAGNUM® products are manufactured in the USA according to our ISO 9001 approved quality program. Structural capacities are developed according to AISC 360 and ACI 318 considering an average design life of 75 years for bare steel in most soil conditions. Hot-dip galvanizing is available upon request. Design and detailing of the structure to which the bearing plate cap is embedded in varies by project and is the responsibility of the registered design professional.

Concrete

Specifications	
Collar Tube	0.5" x 13" I.D. ASTM A252, Fy = 50 ksi or Better
End Effector	25" Ø X 3/4" Steel Bearing Plate
Pile Connection	(2) 1-1/2" ASTM A193 B7 Zinc Coated to ASTM B695/F194
Coating	Galvanized per ASTM A153/A123 (G), Bare Steel (NG), or Epoxy Coated per ICC-ES AC228 (EP)
Compatibility	MH1250-6
Capacity	
Ultimate Compression/ Tension	54 Tons / 54 Tons
Allowable Compression/ Tension	27 Tons / 27 Tons

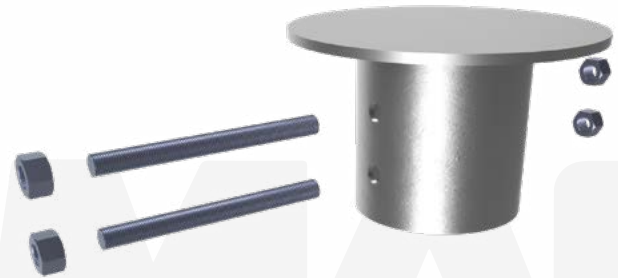

Notes: Cap capacity is developed using the ASD design method and considers strength of collar, end effector, and pile connection. Capacity may be limited by the helical pile, bearing/pullout capacity of soil, or strength of the concrete the cap is embedded in.

Installation Notes: After installation of a MAGNUM® Helical Pile to the correct depth, torque, and capacity, cut-off the pile shaft at the proper elevation. Drill (2) 1-9/16" diameter holes through the shaft using a MAGNUM® drill template, place the cap over the shaft and secure with (2) 1-1/2" bolts. Snug tighten nut. Ensure direct bearing of plate on shaft. Place reinforcing steel, cast concrete and consolidate around the pile cap per project requirements.



- A - As Required for Shear (Min. 4" per IBC)
- B - As required for Compression. See pages 186-187.
- C - As Required for Tension (Min. 3" per IBC). See pages 186-187.



156 Circle Freeway Dr.
Cincinnati, OH 45246
800-822-7437
www.MagnumPiering.com

MAGNUM® MHC1300-13O1616B1 Bearing Plate Cap

Allowable Capacity 100 Tons Compression / 35 Tons Tension

16" x 16" x 7/8" Bearing Plate & 12.5-Inch O.D. Collar
Fits MH1338 Helical Screw Piles

Description: MAGNUM® Bearing Plate Caps consist of a collar tube with bolt hole for connection to MAGNUM® helical screw piles and steel bearing plate for embedment in cast-in-place concrete. MAGNUM® products are manufactured in the USA according to our ISO 9001 approved quality program. Structural capacities are developed according to AISC 360 and ACI 318 considering an average design life of 75 years for bare steel in most soil conditions. Hot-dip galvanizing is available upon request. Design and detailing of the structure to which the bearing plate cap is embedded in varies by project and is the responsibility of the registered design professional.

Specifications	
Collar Tube	0.375"x 12.5"O.D. ASTM A252, Fy = 50 ksi or Better
End Effector	16" x 16" x 7/8" Steel Bearing Plate
Pile Connection	(1) 1-1/2" ASTM A193 B7 Zinc Coated to ASTM B695/F194
Coating	Galvanized per ASTM A153/A123 (G), Bare Steel (NG), or Epoxy Coated per ICC-ES AC228 (EP)
Compatibility	MH1338-6
Capacity	
Ultimate Compression/ Tension	200 Tons / 70 Tons
Allowable Compression/ Tension	100 Tons / 35 Tons

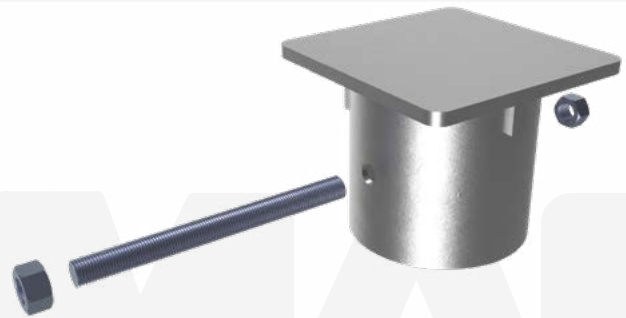

Notes: Cap capacity is developed using the ASD design method and considers strength of collar, end effector, and pile connection. Capacity may be limited by the helical pile, bearing/pullout capacity of soil, or strength of the concrete the cap is embedded in.



Installation Notes: After installation of a MAGNUM® Helical Pile to the correct depth, torque, and capacity, cut-off the pile shaft at the proper elevation. Drill (1) 1-9/16" diameter hole through the shaft using a MAGNUM® drill template, place the cap over the shaft and secure with (1) 1-1/2" bolt. Snug tighten nut. Ensure direct bearing of plate on shaft. Place reinforcing steel, cast concrete and consolidate around the pile cap per project requirements.

- A - As Required for Shear (Min. 4" per IBC)
- B - As required for Compression. See pages 186-187.
- C - As Required for Tension (Min. 3" per IBC). See pages 186-187.

MAGNUM®
PIERING
designed to support

156 Circle Freeway Dr.
Cincinnati, OH 45246
800-822-7437
www.MagnumPiering.com

MAGNUM® MHC1300-13O1616B3 Bearing Plate Cap

Allowable Capacity 100 Tons Compression / 100 Tons Tension

16" x 16" x 7/8" Bearing Plate & 12.5-Inch O.D. Collar
Fits MH1338 Helical Screw Piles

Concrete

Description: MAGNUM® Bearing Plate Caps consist of a collar tube with bolt holes for connection to MAGNUM® helical screw piles and steel bearing plate for embedment in cast-in-place concrete. MAGNUM® products are manufactured in the USA according to our ISO 9001 approved quality program. Structural capacities are developed according to AISC 360 and ACI 318 considering an average design life of 75 years for bare steel in most soil conditions. Hot-dip galvanizing is available upon request. Design and detailing of the structure to which the bearing plate cap is embedded in varies by project and is the responsibility of the registered design professional.

Specifications	
Collar Tube	0.375"x 12.5"O.D. ASTM A252, Fy = 50 ksi or Better
End Effector	16" x 16" x 7/8" Steel Bearing Plate
Pile Connection	(3) 1-1/2" ASTM A193 B7 Zinc Coated to ASTM B695/F194
Coating	Galvanized per ASTM A153/A123 (G), Bare Steel (NG), or Epoxy Coated per ICC-ES AC228 (EP)
Compatibility	MH1338-6
Capacity	
Ultimate Compression/ Tension	200 Tons / 200 Tons
Allowable Compression/ Tension	100 Tons / 100 Tons



Notes: Cap capacity is developed using the ASD design method and considers strength of collar, end effector, and pile connection. Capacity may be limited by the helical pile, bearing/pullout capacity of soil, or strength of the concrete the cap is embedded in.

Installation Notes: After installation of a MAGNUM® Helical Pile to the correct depth, torque, and capacity, cut-off the pile shaft at the proper elevation. Drill (3) 1-9/16" diameter holes through the shaft using a MAGNUM® drill template, place the cap over the shaft and secure with (3) 1-1/2" bolts. Snug tighten nut. Ensure direct bearing of plate on shaft. Place reinforcing steel, cast concrete and consolidate around the pile cap per project requirements.

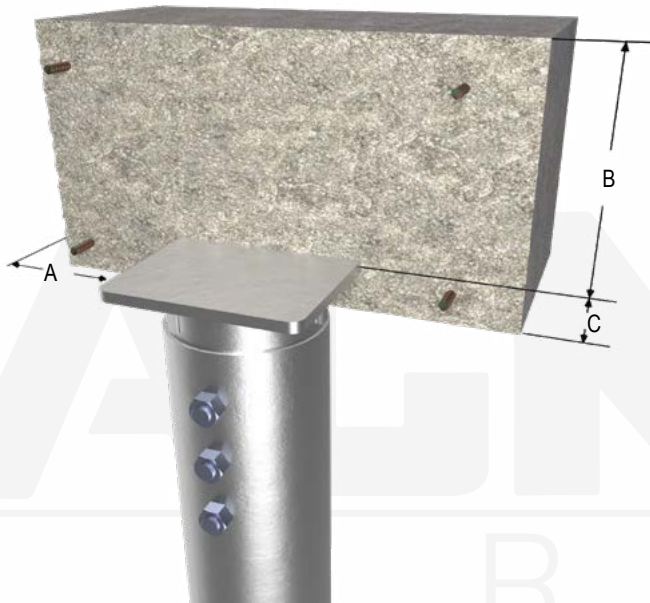

- A - As Required for Shear (Min. 4" per IBC)
- B - As required for Compression. See pages 186-187.
- C - As Required for Tension (Min. 3" per IBC). See pages 186-187.



156 Circle Freeway Dr.
Cincinnati, OH 45246
800-822-7437
www.MagnumPiering.com

MAGNUM® MHC1300-16P1818B2 Bearing Plate Cap

Allowable Capacity 93 Tons Compression / 93 Tons Tension

18" x 18" x 1" Bearing Plate & 16.25-Inch I.D. Collar
Fits MH1650 Helical Screw Piles

Description: MAGNUM® Bearing Plate Caps consist of a collar tube with bolt holes for connection to MAGNUM® helical screw piles and steel bearing plate for embedment in cast-in-place concrete. MAGNUM® products are manufactured in the USA according to our ISO 9001 approved quality program. Structural capacities are developed according to AISC 360 and ACI 318 considering an average design life of 75 years for bare steel in most soil conditions. Hot-dip galvanizing is available upon request. Design and detailing of the structure to which the bearing plate cap is embedded in varies by project and is the responsibility of the registered design professional.

Specifications	
Collar Tube	0.5" x 16.25" I.D. A5TM A252, Fy = 50 ksi or Better
End Effector	18" x 18" x 1" Steel Bearing Plate
Pile Connection	(2) 1-1/2" ASTM A193 B7 Zinc Coated to ASTM B695/F194
Coating	Galvanized per ASTM A153/A123 (G), Bare Steel (NG), or Epoxy Coated per ICC-ES AC228 (EP)
Compatibility	MH1650-6
Capacity	
Ultimate Compression/ Tension	186 Tons / 186 Tons
Allowable Compression/ Tension	93 Tons / 93 Tons

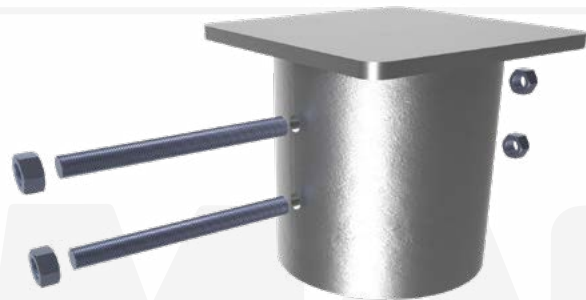

Notes: Cap capacity is developed using the ASD design method and considers strength of collar, end effector, and pile connection. Capacity may be limited by the helical pile, bearing/pullout capacity of soil, or strength of the concrete the cap is embedded in.

Installation Notes: After installation of a MAGNUM® Helical Pile to the correct depth, torque, and capacity, cut-off the pile shaft at the proper elevation. Drill (2) 1-9/16" diameter holes through the shaft using a MAGNUM® drill template, place the cap over the shaft and secure with (2) 1-1/2" bolts. Snug tighten nut. Ensure direct bearing of plate on shaft. Place reinforcing steel, cast concrete and consolidate around the pile cap per project requirements.

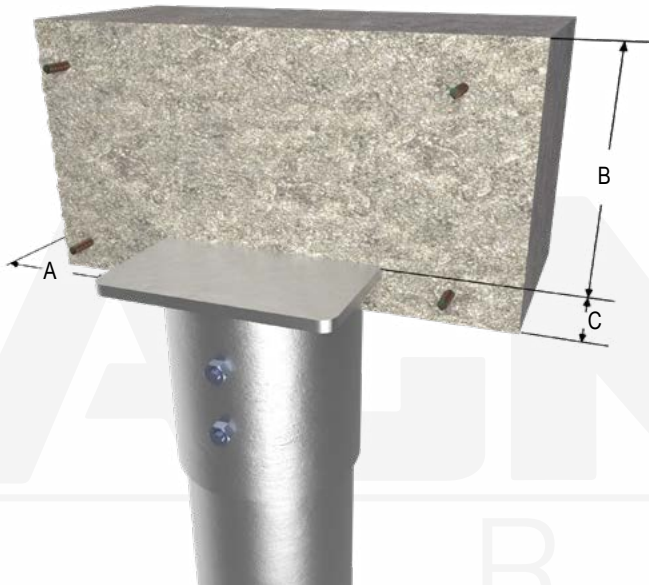

- A - As Required for Shear (Min. 4" per IBC)
- B - As required for Compression. See pages 186-187.
- C - As Required for Tension (Min. 3" per IBC). See pages 186-187.

MAGNUM®
P I E R I N G
designed to support

156 Circle Freeway Dr.
Cincinnati, OH 45246
800-822-7437
www.MagnumPiering.com

MAGNUM® MHC1300-18O2424B3 Bearing Plate Cap

Allowable Capacity 119 Tons Compression / 119 Tons Tension

24" x 24" x 7/8" Bearing Plate & 19.0-Inch I.D Collar
Fits MH1843 Helical Screw Piles

Description: MAGNUM® Bearing Plate Caps consist of a collar tube with bolt holes for connection to MAGNUM® helical screw piles and steel bearing plate for embedment in cast-in-place concrete. MAGNUM® products are manufactured in the USA according to our ISO 9001 approved quality program. Structural capacities are developed according to AISC 360 and ACI 318 considering an average design life of 75 years for bare steel in most soil conditions. Hot-dip galvanizing is available upon request. Design and detailing of the structure to which the bearing plate cap is embedded in varies by project and is the responsibility of the registered design professional.

Concrete

Specifications	
Collar Tube	0.5" x 19" I.D. A5TM A252, Fy = 50 ksi or Better
End Effector	24" x 24" x 7/8" Steel Bearing Plate
Pile Connection	(3) 1-1/2" ASTM A193 B7 Zinc Coated to ASTM B695/F194
Coating	Galvanized per ASTM A153/A123 (G), Bare Steel (NG), or Epoxy Coated per ICC-ES AC228 (EP)
Compatibility	MH1843-6
Capacity	
Ultimate Compression/ Tension	238 Tons / 238 Tons
Allowable Compression/ Tension	119 Tons / 119 Tons

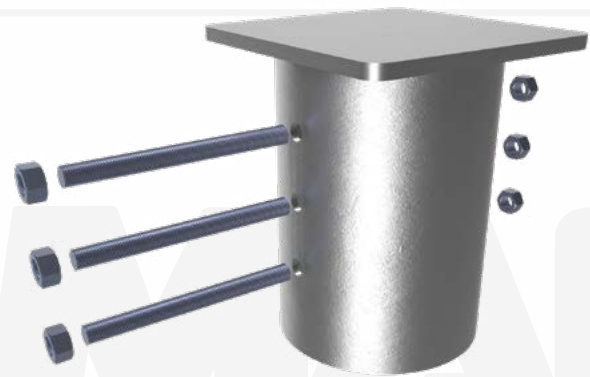

Notes: Cap capacity is developed using the ASD design method and considers strength of collar, end effector, and pile connection. Capacity may be limited by the helical pile, bearing/pullout capacity of soil, or strength of the concrete the cap is embedded in.

Installation Notes: After installation of a MAGNUM® Helical Pile to the correct depth, torque, and capacity, cut-off the pile shaft at the proper elevation. Drill (3) 1-9/16" diameter holes through the shaft using a MAGNUM® drill template, place the cap over the shaft and secure with (3) 1-1/2" bolts. Snug tighten nut. Ensure direct bearing of plate on shaft. Place reinforcing steel, cast concrete and consolidate around the pile cap per project requirements.



- A - As Required for Shear (Min. 4" per IBC)
- B - As required for Compression. See pages 186-187.
- C - As Required for Tension (Min. 3" per IBC). See pages 186-187.



156 Circle Freeway Dr.
Cincinnati, OH 45246
800-822-7437
www.MagnumPiering.com

MAGNUM® MHC2300-2K55T1 Clamp Cap

Allowable Capacity 16 Tons Compression / 0.5 Tons Tension

5" x 5" x 3/8" Bearing Plate & 3.0-Inch I.D. Collar
Fits MH222, MH227 Helical Piles

Description: MAGNUM® Clamp Caps consist of a collar tube with threaded bolt hole for clamp connection to MAGNUM® helical piles and steel bearing plate for embedment in cast-in-place reinforced concrete. MAGNUM® products are manufactured in the USA according to our ISO 9001 approved quality program. Structural capacities are developed according to AISC 360 and ACI 318 considering an average design life of 75 years for bare steel in most soil conditions. Hot-dip galvanizing is available upon request. Design and detailing of the structure to which bearing plate cap is embedded in varies by project and is the responsibility of the registered design professional.

Specifications	
Collar Tube	0.25" x 3.0" I.D. ASTM A252, Fy = 80 ksi or Better
End Effector	5" x 5" x 3/8" Steel Bearing Plate
Pile Connection	(1) 3/4"-16 SAE J429 Grade 8 Zinc Coated to ASTM B695/F1941 Installation Torque 50 ft-lb min, 60 ft-lb max
Coating	Galvanized per ASTM A153/A123 (G), Bare Steel (NG), or Epoxy Coated per ICC-ES AC228 (EP)
Compatibility	MH222, MH227(-6)
Capacity	
Ultimate Compression/ Tension	32 Tons / 1 Ton
Allowable Compression/ Tension	16 Tons / 0.5 Tons

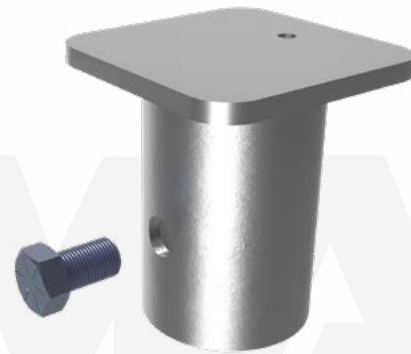

Notes: Cap capacity is developed using the ASD design method and considers strength of collar, end effector, and pile connection. Capacity may be limited by the helical pile, bearing/pullout capacity of soil, or strength of the concrete the cap is embedded in.

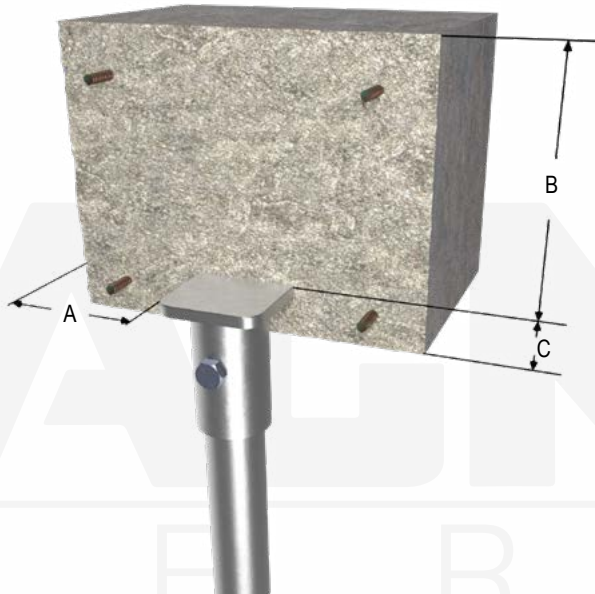

A - As Required for Shear (Min. 4" per IBC)
B - As required for Compression. See pages 186-187.
C - As Required for Tension (Min. 3" per IBC). See pages 186-187.

Installation Notes: After installation of a MAGNUM® Helical Pile to the correct depth, torque, and capacity, cut-off the pile shaft at the proper elevation. Place the cap over the shaft and secure with (1) 3/4" fine thread bolt. Tighten to specified torque. Ensure direct bearing of plate on shaft. Place reinforcing steel, cast concrete and consolidate around the pile cap per project requirements.

* Plate must directly bear on shaft for compression capacity shown.
** Bolt must be new, clean, dry and free from any dust, rust or paint & threaded hole must be clean, dry and free of any surface dust, rust, paint or galvanizing for tension capacity shown. Manufacture applied lubricating wax on bolts is acceptable.

MAGNUM
PIERING
designed to support

156 Circle Freeway Dr.
Cincinnati, OH 45246
800-822-7437
www.MagnumPiering.com

MAGNUM® MHC2300-3M66T1 Clamp Cap

Allowable Capacity 23 Tons Compression / 0.5 Tons Tension

6" x 6" x 5/8" Bearing Plate & 3.13-Inch I.D. Collar
 Fits MH313B, MH313BR, MH325B & MH325BR(-6) Helical Piles

Description: MAGNUM® Clamp Caps consist of a collar tube with threaded bolt hole for clamp connection to MAGNUM® helical piles and steel bearing plate for embedment in cast-in-place reinforced concrete. MAGNUM® products are manufactured in the USA according to our ISO 9001 approved quality program. Structural capacities are developed according to AISC 360 and ACI 318 considering an average design life of 75 years for bare steel in most soil conditions. Hot-dip galvanizing is available upon request. Design and detailing of the structure to which bearing plate cap is embedded in varies by project and is the responsibility of the registered design professional.

Concrete

Specifications	
Collar Tube	0.25" x 3.13" I.D. ASTM A513, Fy = 65 ksi or Better
End Effector	6" x 6" x 5/8" Steel Bearing Plate
Pile Connection	(1) 3/4"-16 SAE J429 Grade 8 Zinc Coated to ASTM B695/F1941 Installation Torque 50 ft-lb min, 60 ft-lb max
Coating	Galvanized per ASTM A153/A123 (G), Bare Steel (NG), or Epoxy Coated per ICC-ES AC228 (EP)
Compatibility	MH313B, MH313BR, MH325B, MH325BR(-6)
Capacity	
Ultimate Compression/ Tension	46 Tons / 1 Ton
Allowable Compression/ Tension	23 Tons / 0.5 Tons

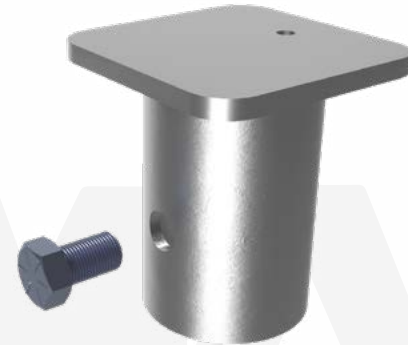

Notes: Cap capacity is developed using the ASD design method and considers strength of collar, end effector, and pile connection. Capacity may be limited by the helical pile, bearing/pullout capacity of soil, or strength of the concrete the cap is embedded in.

Installation Notes: After installation of a MAGNUM® Helical Pile to the correct depth, torque, and capacity, cut-off the pile shaft at the proper elevation. Place the cap over the shaft and secure with (1) 3/4" fine thread bolt. Tighten to specified torque. Ensure direct bearing of plate on shaft. Place reinforcing steel, cast concrete and consolidate around the pile cap per project requirements.

* Plate must directly bear on shaft for compression capacity shown.
 ** Bolt must be new, clean, dry and free from any dust, rust or paint & threaded hole must be clean, dry and free of any surface dust, rust, paint or galvanizing for tension capacity shown. Manufacture applied lubricating wax on bolts is acceptable.

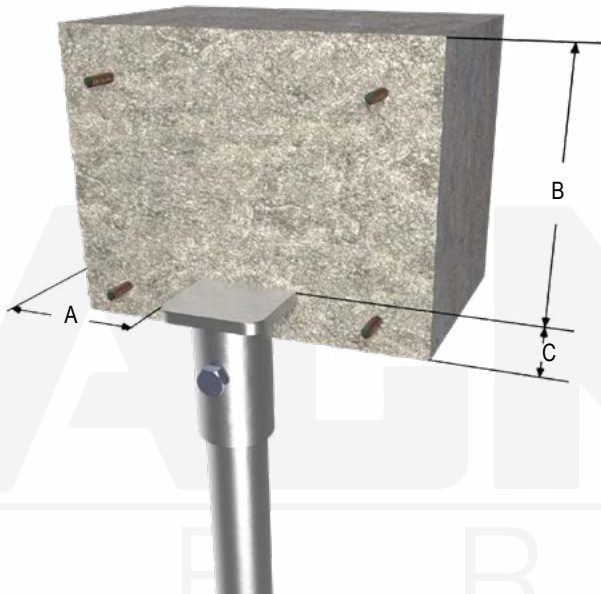

A - As Required for Shear (Min. 4" per IBC)
 B - As required for Compression. See pages 186-187.
 C - As Required for Tension (Min. 3" per IBC). See pages 186-187.



156 Circle Freeway Dr.
 Cincinnati, OH 45246
 800-822-7437
www.MagnumPiering.com

MAGNUM® MHC2300-4N88T1 Clamp Cap

Allowable Capacity 55 Tons Compression / 1 Ton Tension

8" x 8" x 3/4" Bearing Plate & 4.63-Inch I.D. Collar
Fits MH429 & MH434 Helical Piles

Description: MAGNUM® Clamp Caps consist of a collar tube with threaded bolt hole for clamp connection to MAGNUM® helical piles and steel bearing plate for embedment in cast-in-place reinforced concrete. MAGNUM® products are manufactured in the USA according to our ISO 9001 approved quality program. Structural capacities are developed according to AISC 360 and ACI 318 considering an average design life of 75 years for bare steel in most soil conditions. Hot-dip galvanizing is available upon request. Design and detailing of the structure to which bearing plate cap is embedded in varies by project and is the responsibility of the registered design professional.

Specifications	
Collar Tube	0.31" x 4.63" I.D. ASTM A252, Fy = 65 ksi or Better
End Effector	8" x 8" x 3/4" Steel Bearing Plate
Pile Connection	(1) 7/8"-9 SAE J429 Grade 8 Zinc Coated to ASTM B695/F1941 Installation Torque 75 ft-lb min, 100 ft-lb max
Coating	Galvanized per ASTM A153/A123 (G), Bare Steel (NG), or Epoxy Coated per ICC-ES AC228 (EP)
Compatibility	MH429(-6), MH434(-6)
Capacity	
Ultimate Compression/ Tension	110 Tons / 2 Tons
Allowable Compression/ Tension	55 Tons / 1 Ton

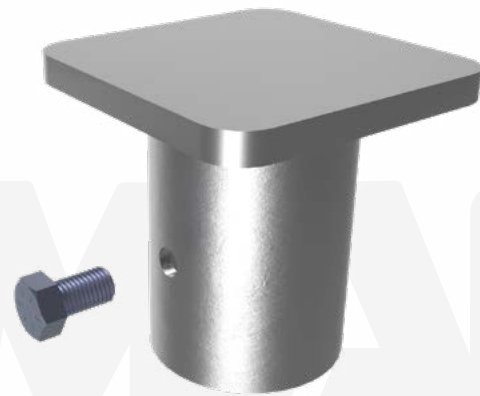

Notes: Cap capacity is developed using the ASD design method and considers strength of collar, end effector, and pile connection. Capacity may be limited by the helical pile, bearing/pullout capacity of soil, or strength of the concrete the cap is embedded in.

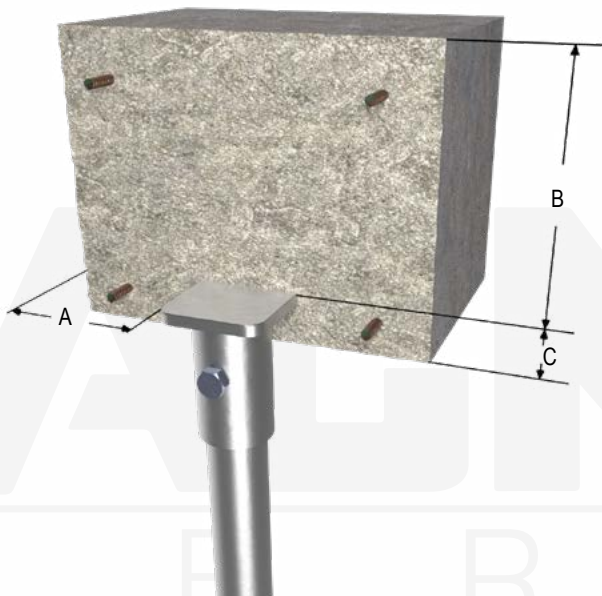

A - As Required for Shear (Min. 4" per IBC)
B - As required for Compression. See pages 186-187.
C - As Required for Tension (Min. 3" per IBC). See pages 186-187.

Installation Notes: After installation of a MAGNUM® Helical Pile to the correct depth, torque, and capacity, cut-off the pile shaft at the proper elevation. Place the cap over the shaft and secure with (1) 3/4" fine thread bolt. Tighten to specified torque. Ensure direct bearing of plate on shaft. Place reinforcing steel, cast concrete and consolidate around the pile cap per project requirements.

* Plate must directly bear on shaft for compression capacity shown.
** Bolt must be new, clean, dry and free from any dust, rust or paint & threaded hole must be clean, dry and free of any surface dust, rust, paint or galvanizing for tension capacity shown. Manufacture applied lubricating wax on bolts is acceptable.

MAGNUM®
P I E R I N G
designed to support

156 Circle Freeway Dr.
Cincinnati, OH 45246
800-822-7437
www.MagnumPiering.com

MAGNUM® MHC1654-3M66S040BR1 Rebar Plate Cap

ASD: 59 Kips Comp. / 44 Kips Tens.* / 3.7 Kip-ft Moment*

6" Sq. x 5/8" Bearing Plate w/ (4) #5 Headed Rebar Studs & 3-1/8" I.D. Collar

Fits MH325BR(-6) Helical Piles

Description: MAGNUM® Rebar Plate Caps provide superior embedment in concrete pile caps. Utilizing rigid bolted couplings to connect to helical piles and headed rebar studs to transfer tension and moment from the concrete pile cap into the pile. MAGNUM® products are manufactured in the USA according to our ISO 9001 approved Quality Program. Structural capacities are developed according to AISC 360 and ACI 318 considering an average design life of 75 years for bare steel in most soil conditions. Hot-dip galvanizing is available upon request. Design and detailing of the structure to which rebar plate cap is embedded in varies by project and is the responsibility of the registered design professional.

Specifications	
Collar Tube	3-1/8" I.D. ASTM A252, Fy = 65 ksi min.
End Effector	6" Sq. x 5/8" Steel Bearing Plate w/ (4) #5 Headed Rebar Studs, ASTM A706
Pile Connection	(1) 1" SAE J429 Grade 8 Bolt Zinc Coated to ASTM B695/F1941 when used with Galvanized Piles
Coating	Bare Steel (NG), Galvanized per ASTM A153/A123 (G)
Compatibility	MH325BR(-6)
Capacity	
Allowable Compression	59 Kips
*Maximum Allowable Tension	44 Kips
*Maximum Allowable Moment	3.7 Kip-Ft

*Tension & Moment capacity are interactive. Utilize the Combined Loading Chart below.

Notes: Cap capacity is developed using the ASD design method and considers strength of collar, end effector, and pile connection. Rebar studs conform to ACI 318 dimensions and are designed to have full tension development in normal weight concrete with 28-day f'c ≥ 3,000 psi. Capacity may be limited by the helical pile, bearing/pullout capacity of soil, or strength of the concrete the cap is embedded in.

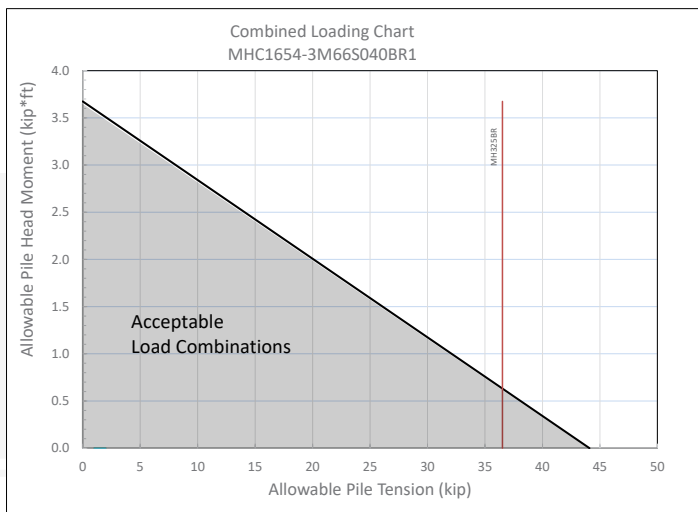

Installation Notes: After installation of a MAGNUM® Helical Pile to the correct depth, torque, and capacity, cut-off the pile shaft at the proper elevation. Drill (1) 1-1/16" thru hole using a MAGNUM® drill template, place the cap over the shaft and secure with (1) 1" bolt. Ensure direct bearing of plate on shaft. Snug tighten nut. Tighten set screw to prevent wobble during concrete placement. Place reinforcing steel, cast concrete and consolidate around the pile cap per project requirements.

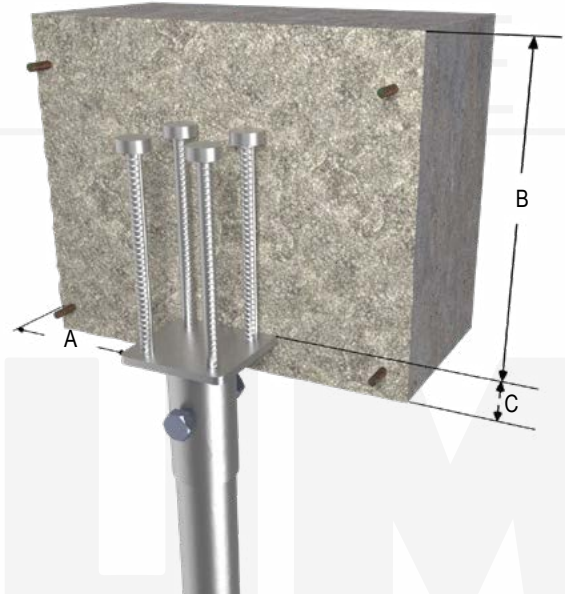

- A - As Required for Shear (Min. 4" per IBC)
- B - As required for Compression
- C - Min. 3" per IBC

MAGNUM
PIERING
designed to support

156 Circle Freeway Dr.
Cincinnati, OH 45246
800-822-7437
www.MagnumPiering.com

MAGNUM® MHC1658-4P10S080B2 Rebar Plate Cap

ASD: 108 Kips Comp. / 88 Kips Tens.* / 14.7 Kip-ft Moment*

10" Diameter x 1" Bearing Plate w/ (8) #5 Headed Rebar Studs & 4-5/8" I.D. Collar

Fits MH429(-6) & MH434(-6) Helical Piles

Description: MAGNUM® Rebar Plate Caps provide superior embedment in concrete pile caps. Utilizing rigid bolted couplings to connect to helical piles and headed rebar studs to transfer tension and moment from the concrete pile cap into the pile. MAGNUM® products are manufactured in the USA according to our ISO 9001 approved Quality Program. Structural capacities are developed according to AISC 360 and ACI 318 considering an average design life of 75 years for bare steel in most soil conditions. Hot-dip galvanizing is available upon request. Design and detailing of the structure to which rebar plate cap is embedded in varies by project and is the responsibility of the registered design professional.

Specifications	
Collar Tube	4-5/8" I.D. ASTM A252, Fy = 80 ksi min.
End Effector	10" Diameter x 1" Steel Bearing Plate w/ (8) #5 Headed Rebar Studs, ASTM A706
Pile Connection	(2) 1-1/4" SAE J429 Grade 5 Bolt Zinc Coated to ASTM B695/F1941 when used with Galvanized Piles
Coating	Bare Steel (NG), Galvanized per ASTM A153/A123 (G)
Compatibility	MH429(-6) & MH434(-6)
Capacity	
Allowable Compression	108 Kips
*Maximum Allowable Tension	88 Kips
*Maximum Allowable Moment	14.7 Kip-Ft



*Tension & Moment capacity are interactive. Utilize the Combined Loading Chart below.

Notes: Cap capacity is developed using the ASD design method and considers strength of collar, end effector, and pile connection. Rebar studs conform to ACI 318 dimensions and are designed to have full tension development in normal weight concrete with 28-day $f'_c \geq 3,000$ psi. Capacity may be limited by the helical pile, bearing/pullout capacity of soil, or strength of the concrete the cap is embedded in.

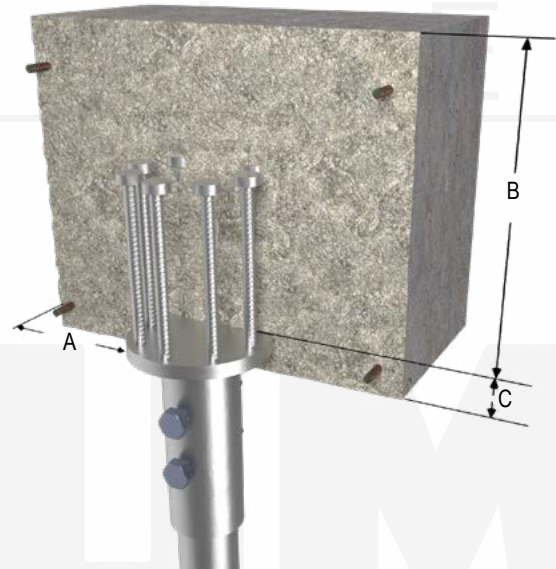
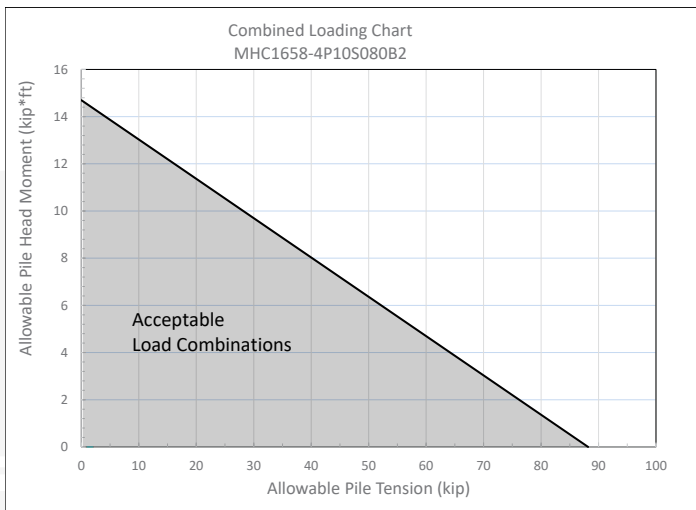

A - As Required for Shear (Min. 4" per IBC)
 B - As required for Compression
 C - Min. 3" per IBC

Installation Notes: After installation of a MAGNUM® Helical Pile to the correct depth, torque, and capacity, cut-off the pile shaft at the proper elevation. Drill (2) 1-5/16" thru holes using a MAGNUM® drill template, place the cap over the shaft and secure with (2) 1-1/4" bolts. Ensure direct bearing of plate on shaft. Snug tighten nut. Place reinforcing steel, cast concrete and consolidate around the pile cap per project requirements.



156 Circle Freeway Dr.
 Cincinnati, OH 45246
 800-822-7437
www.MagnumPiering.com

MAGNUM® MHC1666-5P12S105B1 Rebar Plate Cap

ASD: 151 Kips Comp. / 79 Kips Tens.* / 20.8 Kip-ft Moment*

12" Dia. x 1" Bearing Plate w/ (6) #6 Headed Rebar Studs & 5-3/4" I.D. Collar
Fits MH530-6, MH536-6, MH542-6 & MH547-6 Helical Piles

Description: MAGNUM® Rebar Plate Caps provide superior embedment in concrete pile caps. Utilizing rigid bolted couplings to connect to helical piles and headed rebar studs to transfer tension and moment from the concrete pile cap into the pile. MAGNUM® products are manufactured in the USA according to our ISO 9001 approved Quality Program. Structural capacities are developed according to AISC 360 and ACI 318 considering an average design life of 75 years for bare steel in most soil conditions. Hot-dip galvanizing is available upon request. Design and detailing of the structure to which rebar plate cap is embedded in varies by project and is the responsibility of the registered design professional.

Specifications	
Collar Tube	5-3/4" I.D. ASTM A252, Fy = 50 ksi min.
End Effector	12" Diameter x 1" Steel Bearing Plate w/ (6) #6 Headed Rebar Studs, ASTM A706
Pile Connection	(1) 1-1/2" SAE J429 Grade 5 Bolt Zinc Coated to ASTM B695/F1941 when used with Galvanized Piles
Coating	Bare Steel (NG), Galvanized per ASTM A153/A123 (G)
Compatibility	MH530-6, MH536-6, MH542-6 & MH547-6
Capacity	
Allowable Compression	151 Kips
*Maximum Allowable Tension	79 Kips
*Maximum Allowable Moment	20.8 Kip-Ft

*Tension & Moment capacity are interactive. Utilize the Combined Loading Chart below.

Notes: Cap capacity is developed using the ASD design method and considers strength of collar, end effector, and pile connection. Rebar studs conform to ACI 318 dimensions and are designed to have full tension development in normal weight concrete with 28-day $f'c \geq 3,000$ psi. Capacity may be limited by the helical pile, bearing/pullout capacity of soil, or strength of the concrete the cap is embedded in.

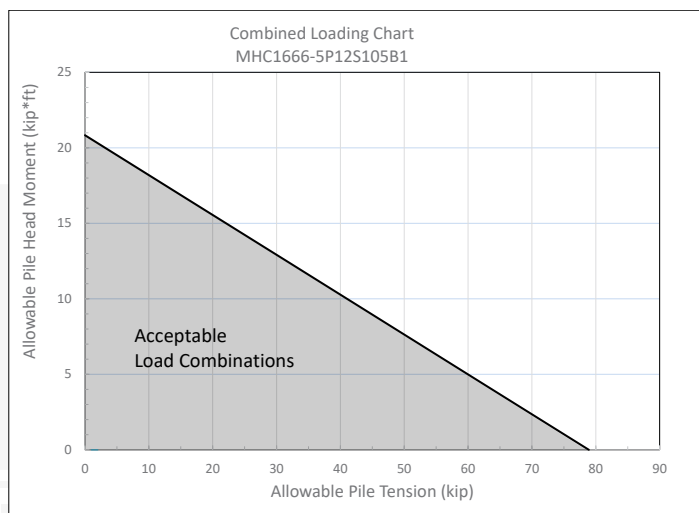

Installation Notes: After installation of a MAGNUM® Helical Pile to the correct depth, torque, and capacity, cut-off the pile shaft at the proper elevation. Drill (1) 1-9/16" thru hole using a MAGNUM® drill template, place the cap over the shaft and secure with (1) 1-1/2" bolt. Ensure direct bearing of plate on shaft. Snug tighten nut. Tighten set screw to prevent wobble during concrete placement. Place reinforcing steel, cast concrete and consolidate around the pile cap per project requirements.



Rebar Caps

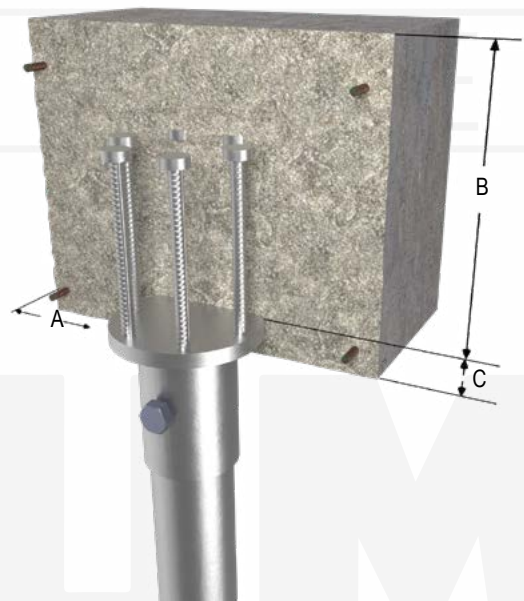

- A - As Required for Shear (Min. 4" per IBC)
- B - As required for Compression
- C - Min. 3" per IBC

MAGNUM
PIERING
designed to support

156 Circle Freeway Dr.
Cincinnati, OH 45246
800-822-7437

www.MagnumPiering.com

MAGNUM® MHC1688-7R15S130B3 Rebar Plate Cap

ASD: 224 Kips Comp. / 226 Kips Tens.* / 61 Kip-ft Moment*

15" Dia. x 1-1/4" Bearing Plate w/ (8) #8 Headed Rebar Studs & 7-1/4" I.D. Collar
Fits MH736-6 & MH745-6 Helical Piles

Description: MAGNUM® Rebar Plate Caps provide superior embedment in concrete pile caps. Utilizing rigid bolted couplings to connect to helical screw piles and headed rebar studs to transfer tension and moment from the concrete pile cap into the pile. MAGNUM® products are manufactured in the USA according to our ISO 9001 approved Quality Program. Structural capacities are developed according to AISC 360 and ACI 318 considering an average design life of 75 years for bare steel in most soil conditions. Hot-dip galvanizing is available upon request. Design and detailing of the structure to which rebar plate cap is embedded in varies by project and is the responsibility of the registered design professional.

Specifications	
Collar Tube	7-1/4" I.D. ASTM A252, Fy = 65 ksi min.
End Effector	15" Diameter x 1-1/4" Steel Bearing Plate w/ (8) #8 Headed Rebar Studs, ASTM A706
Pile Connection	(3) 1-1/2" ASTM A193 B7 Threaded Rod Zinc Coated to ASTM B695/F1941 when used with Galvanized Piles
Coating	Bare Steel (NG), Galvanized per ASTM A153/A123 (G)
Compatibility	MH736-6 & MH745-6
Capacity	
Allowable Compression	224 Kips
*Maximum Allowable Tension	226 Kips
*Maximum Allowable Moment	61 Kip-Ft

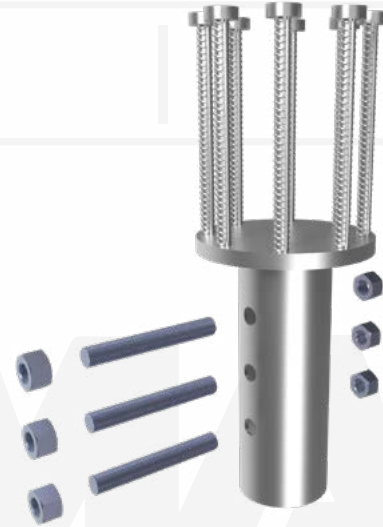

*Tension & Moment capacity are interactive. Utilize the Combined Loading Chart below.

Notes: Cap capacity is developed using the ASD design method and considers strength of collar, end effector, and pile connection. Rebar studs conform to ACI 318 dimensions and are designed to have full tension development in normal weight concrete with 28-day $f'_c \geq 3,000$ psi. Capacity may be limited by the helical pile, bearing/pullout capacity of soil, or strength of the concrete the cap is embedded in.

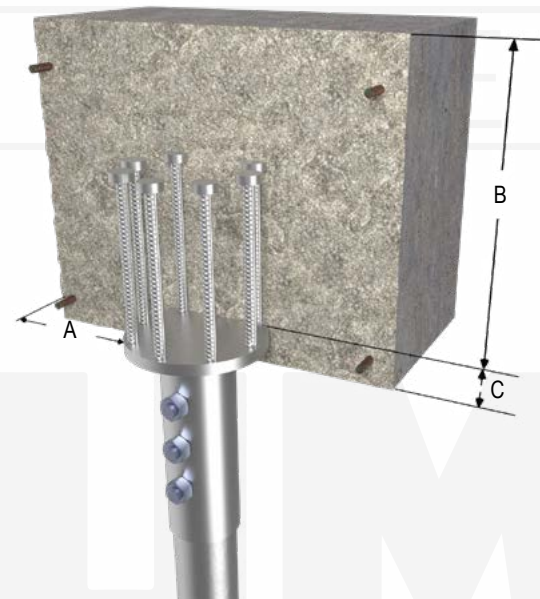
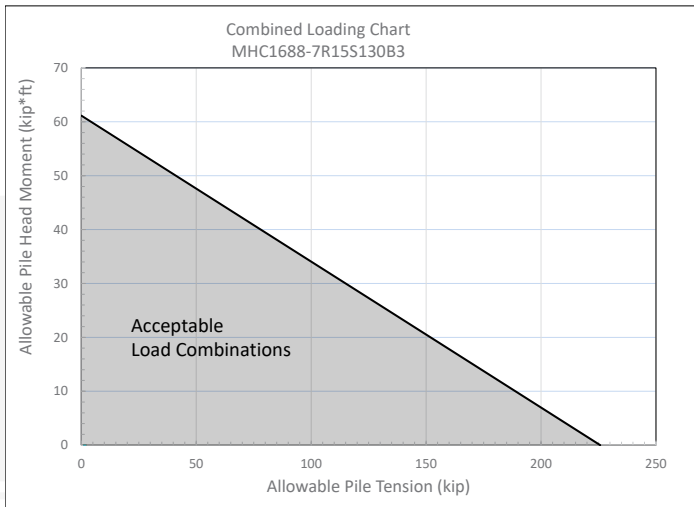

A - As Required for Shear (Min. 4" per IBC)
B - As required for Compression
C - Min. 3" per IBC

Installation Notes: After installation of a MAGNUM® Helical Pile to the correct depth, torque, and capacity, cut-off the pile shaft at the proper elevation. Drill (3) 1-9/16" thru holes using a MAGNUM® drill template, place the cap over the shaft and secure with (3) 1-1/2" bolts. Ensure direct bearing of plate on shaft. Snug tighten nut. Place reinforcing steel, cast concrete and consolidate around the pile cap per project requirements.

MAGNUM
PIERING
designed to support

156 Circle Freeway Dr.
Cincinnati, OH 45246
800-822-7437
www.MagnumPiering.com

MAGNUM® MHC1678-9P16S132B3 Rebar Plate Cap

ASD: 220.5 Kips Comp. / 172.8 Kips Tens.* / 47.7 Kip-ft Moment*

16" Dia. x 1" Bearing Plate w/ (8) #7 Headed Rebar Studs & 9-7/8" I.D. Collar

Fits MH939-6 Helical Piles

Description: MAGNUM® Rebar Plate Caps provide superior embedment in concrete pile caps. Utilizing rigid bolted couplings to connect to helical screw piles and headed rebar studs to transfer tension and moment from the concrete pile cap into the pile. MAGNUM® products are manufactured in the USA according to our ISO 9001 approved Quality Program. Structural capacities are developed according to AISC 360 and ACI 318 considering an average design life of 75 years for bare steel in most soil conditions. Hot-dip galvanizing is available upon request. Design and detailing of the structure to which rebar plate cap is embedded in varies by project and is the responsibility of the registered design professional.

Specifications	
Collar Tube	9-7/8" I.D. ASTM A252, Fy = 55 ksi min.
End Effector	16" Diameter x 1" Steel Bearing Plate w/ (8) #7 Headed Rebar Studs, ASTM A706
Pile Connection	(3) 1-1/2" ASTM A193 B7 Threaded Rod Zinc Coated to ASTM B695/F1941 when used with Galvanized Piles
Coating	Bare Steel (NG), Galvanized per ASTM A153/A123 (G)
Compatibility	MH939-6
Capacity	
Allowable Compression	220.5 Kips
*Maximum Allowable Tension	172.8 Kips
*Maximum Allowable Moment	47.7 Kip-Ft

*Tension & Moment capacity are interactive. Utilize the Combined Loading Chart below.

Notes: Cap capacity is developed using the ASD design method and considers strength of collar, end effector, and pile connection. Rebar studs conform to ACI 318 dimensions and are designed to have full tension development in normal weight concrete with 28-day $f'c \geq 3,000$ psi. Capacity may be limited by the helical pile, bearing/pullout capacity of soil, or strength of the concrete the cap is embedded in.

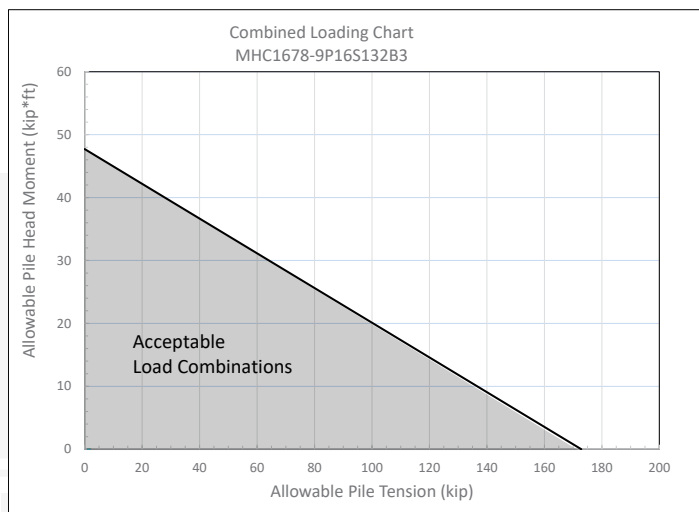

Installation Notes: After installation of a MAGNUM® Helical Pile to the correct depth, torque, and capacity, cut-off the pile shaft at the proper elevation. Drill (3) 1-9/16" thru holes using a MAGNUM® drill template, place the cap over the shaft and secure with (3) 1-1/2" bolts. Ensure direct bearing of plate on shaft. Snug tighten nut. Place reinforcing steel, cast concrete and consolidate around the pile cap per project requirements.

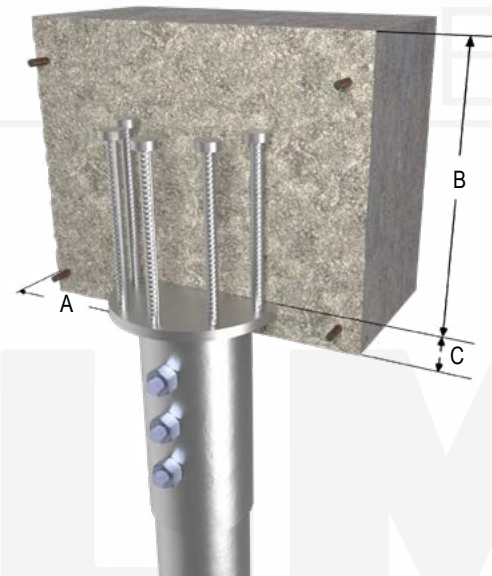

- A - As Required for Shear (Min. 4" per IBC)
- B - As required for Compression
- C - Min. 3" per IBC

MAGNUM
PIERING
designed to support

156 Circle Freeway Dr.
Cincinnati, OH 45246
800-822-7437

www.MagnumPiering.com

MAGNUM® MHC16912-10X24S215B3 Rebar Plate Cap

ASD: 524.1 Kips Comp. / 430.8 Kips Tens.* / 193 Kip-ft Moment*

24" Dia. x 2" Bearing Plate w/ (12) #9 Headed Rebar Studs & 11" I.D. Collar
Fits MH1050-6 Helical Piles

Description: MAGNUM® Rebar Plate Caps provide superior embedment in concrete pile caps. Utilizing rigid bolted couplings to connect to helical screw piles and headed rebar studs to transfer tension and moment from the concrete pile cap into the pile. MAGNUM® products are manufactured in the USA according to our ISO 9001 approved Quality Program. Structural capacities are developed according to AISC 360 and ACI 318 considering an average design life of 75 years for bare steel in most soil conditions. Hot-dip galvanizing is available upon request. Design and detailing of the structure to which rebar plate cap is embedded in varies by project and is the responsibility of the registered design professional.

Specifications	
Collar Tube	11" I.D. ASTM A252, Fy = 80 ksi min.
End Effector	24" Diameter x 2" Steel Bearing Plate w/ (12) #9 Headed Rebar Studs, ASTM A706
Pile Connection	(3) 2" ASTM A193 B7 Threaded Rod Zinc Coated to ASTM B695/F1941 when used with Galvanized Piles
Coating	Bare Steel (NG), Galvanized per ASTM A153/A123 (G)
Compatibility	MH1050-6
Capacity	
Allowable Compression	524.1 Kips
*Maximum Allowable Tension	430.8 Kips
*Maximum Allowable Moment	193 Kip-Ft

*Tension & Moment capacity are interactive. Utilize the Combined Loading Chart below.

Notes: Cap capacity is developed using the ASD design method and considers strength of collar, end effector, and pile connection. Rebar studs conform to ACI 318 dimensions and are designed to have full tension development in normal weight concrete with 28-day $f_c \geq 3,000$ psi. Capacity may be limited by the helical pile, bearing/pullout capacity of soil, or strength of the concrete the cap is embedded in.

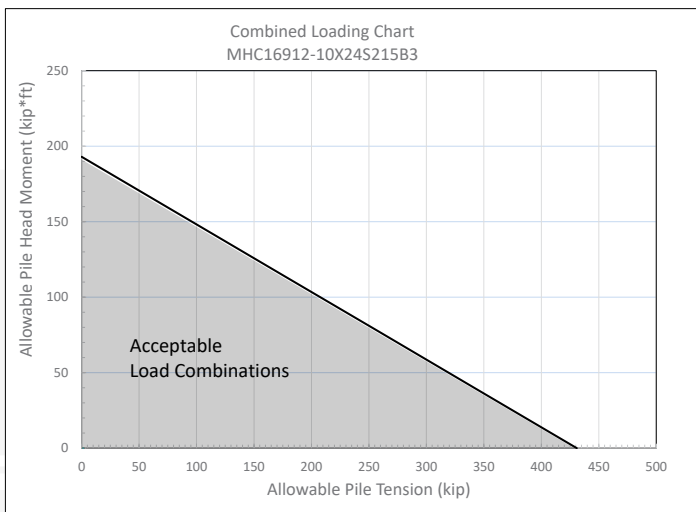

Installation Notes: After installation of a MAGNUM® Helical Pile to the correct depth, torque, and capacity, cut-off the pile shaft at the proper elevation. Drill (3) 2-116" thru holes using a MAGNUM® drill template, place the cap over the shaft and secure with (3) 2" bolts. Ensure direct bearing of plate on shaft. Snug tighten nut. Place reinforcing steel, cast concrete and consolidate around the pile cap per project requirements.

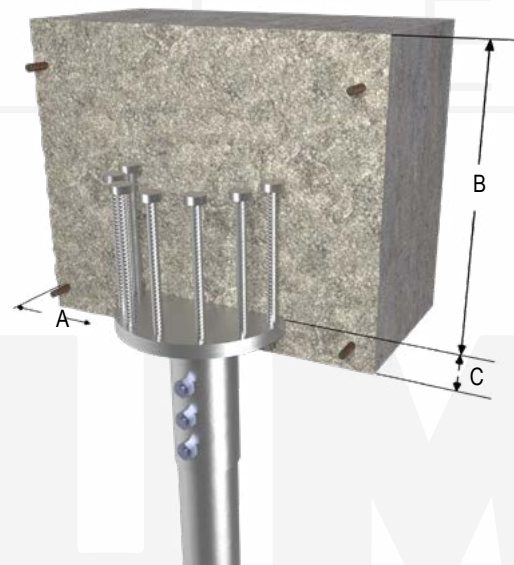

A - As Required for Shear (Min. 4" per IBC)
B - As required for Compression
C - Min. 3" per IBC

MAGNUM
PIERING
designed to support

156 Circle Freeway Dr.
Cincinnati, OH 45246
800-822-7437
www.MagnumPiering.com

MAGNUM® MHC1688-12R20S180B3 Rebar Plate Cap

ASD: 380.7 Kips Comp. / 225.7 Kips Tens.* / 84.7 Kip-ft Moment*

20" Dia. x 1-1/4" Bearing Plate w/ (8) #8 Headed Rebar Studs & 13" I.D. Collar
Fits MH1250-6 Helical Piles

Description: MAGNUM® Rebar Plate Caps provide superior embedment in concrete pile caps. Utilizing rigid bolted couplings to connect to helical screw piles and headed rebar studs to transfer tension and moment from the concrete pile cap into the pile. MAGNUM® products are manufactured in the USA according to our ISO 9001 approved Quality Program. Structural capacities are developed according to AISC 360 and ACI 318 considering an average design life of 75 years for bare steel in most soil conditions. Hot-dip galvanizing is available upon request. Design and detailing of the structure to which rebar plate cap is embedded in varies by project and is the responsibility of the registered design professional.

Specifications	
Collar Tube	13" I.D. ASTM A252, Fy = 50 ksi min.
End Effector	20" Diameter x 1-1/4" Steel Bearing Plate w/ (8) #8 Headed Rebar Studs, ASTM A706
Pile Connection	(3) 1-1/2" ASTM A193 B7 Threaded Rod Zinc Coated to ASTM B695/F1941 when used with Galvanized Piles
Coating	Bare Steel (NG), Galvanized per ASTM A153/A123 (G)
Compatibility	MH1250-6
Capacity	
Allowable Compression	380.7 Kips
*Maximum Allowable Tension	225.7 Kips
*Maximum Allowable Moment	84.7 Kip-Ft



Rebar Caps

*Tension & Moment capacity are interactive. Utilize the Combined Loading Chart below.

Notes: Cap capacity is developed using the ASD design method and considers strength of collar, end effector, and pile connection. Rebar studs conform to ACI 318 dimensions and are designed to have full tension development in normal weight concrete with 28-day $f'c \geq 3,000$ psi. Capacity may be limited by the helical pile, bearing/pullout capacity of soil, or strength of the concrete the cap is embedded in.

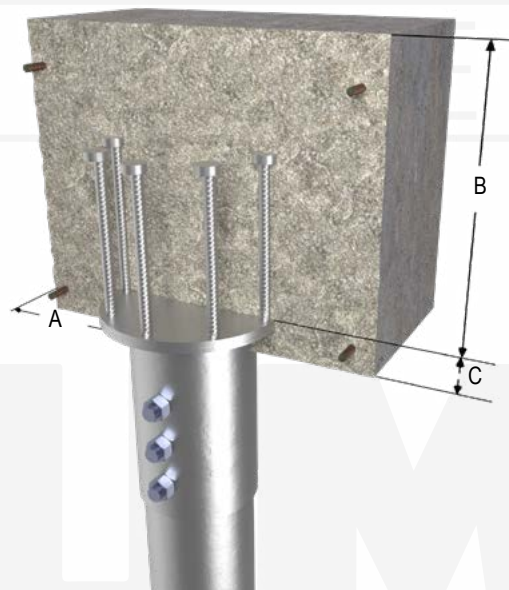
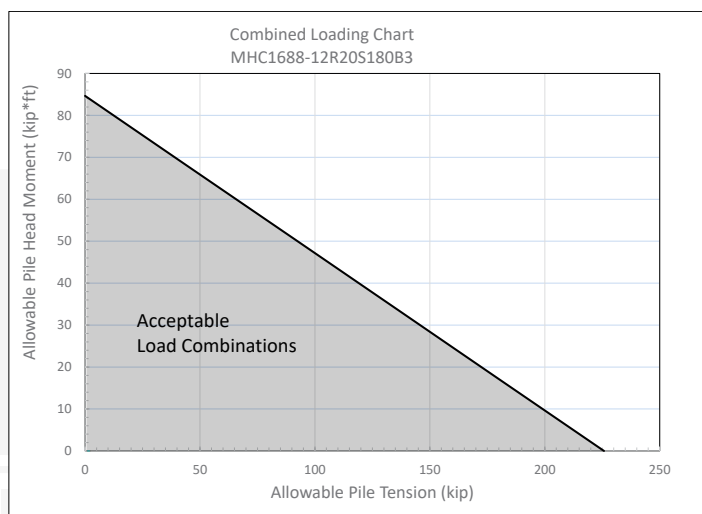

- A - As Required for Shear (Min. 4" per IBC)
- B - As required for Compression
- C - Min. 3" per IBC



Installation Notes: After installation of a MAGNUM® Helical Pile to the correct depth, torque, and capacity, cut-off the pile shaft at the proper elevation. Drill (3) 1-9/16" thru holes using a MAGNUM® drill template, place the cap over the shaft and secure with (3) 1-1/2" bolts. Ensure direct bearing of plate on shaft. Snug tighten nut. Place reinforcing steel, cast concrete and consolidate around the pile cap per project requirements.

156 Circle Freeway Dr.
Cincinnati, OH 45246
800-822-7437
www.MagnumPiering.com

MAGNUM® MHC1688-13T24S210B3 Rebar Plate Cap

ASD: 224.6 Kips Comp. / 225.7 Kips Tens.* / 98.8 Kip-ft Moment*

24" Dia. x 1-1/2" Bearing Plate w/ (8) #8 Headed Rebar Studs & 12-1/2" O.D. Collar
Fits MH1338-6 Helical Piles

Description: MAGNUM® Rebar Plate Caps provide superior embedment in concrete pile caps. Utilizing rigid bolted couplings to connect to helical screw piles and headed rebar studs to transfer tension and moment from the concrete pile cap into the pile. MAGNUM® products are manufactured in the USA according to our ISO 9001 approved Quality Program. Structural capacities are developed according to AISC 360 and ACI 318 considering an average design life of 75 years for bare steel in most soil conditions. Hot-dip galvanizing is available upon request. Design and detailing of the structure to which rebar plate cap is embedded in varies by project and is the responsibility of the registered design professional.

Specifications	
Collar Tube	12-1/2" O.D. ASTM A252, Fy = 65 ksi min.
End Effector	24" Diameter x 1-1/2" Steel Bearing Plate w/ (8) #8 Headed Rebar Studs, ASTM A706
Pile Connection	(3) 1-1/2" ASTM A193 B7 Threaded Rod Zinc Coated to ASTM B695/F1941 when used with Galvanized Piles
Coating	Bare Steel (NG), Galvanized per ASTM A153/A123 (G)
Compatibility	MH1338-6
Capacity	
Allowable Compression	224.6 Kips
*Maximum Allowable Tension	225.7 Kips
*Maximum Allowable Moment	98.8 Kip-Ft

*Tension & Moment capacity are interactive. Utilize the Combined Loading Chart below.

Notes: Cap capacity is developed using the ASD design method and considers strength of collar, end effector, and pile connection. Rebar studs conform to ACI 318 dimensions and are designed to have full tension development in normal weight concrete with 28-day $f'c \geq 3,000$ psi. Capacity may be limited by the helical pile, bearing/pullout capacity of soil, or strength of the concrete the cap is embedded in.

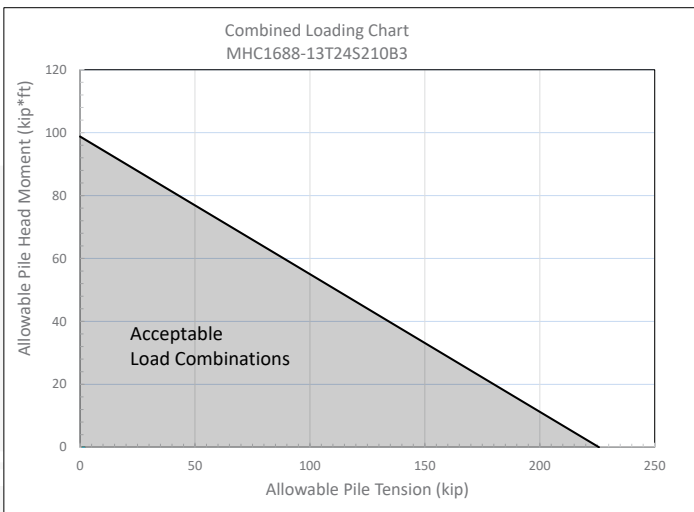

Installation Notes: After installation of a MAGNUM® Helical Pile to the correct depth, torque, and capacity, cut-off the pile shaft at the proper elevation. Drill (3) 1-9/16" thru holes using a MAGNUM® drill template, place the cap over the shaft and secure with (3) 1-1/2" bolts. Ensure direct bearing of plate on shaft. Snug tighten nut. Place reinforcing steel, cast concrete and consolidate around the pile cap per project requirements.

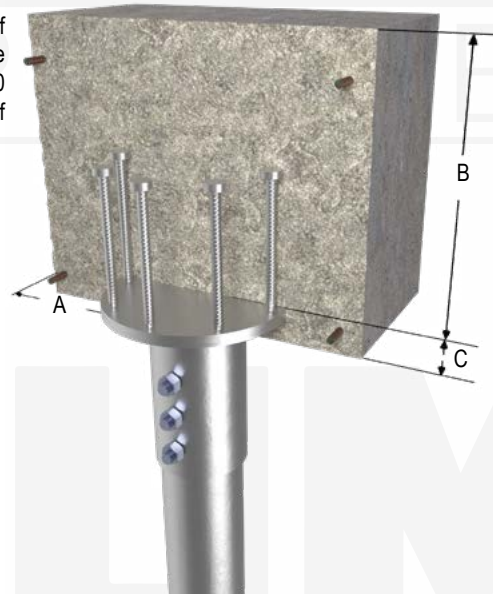
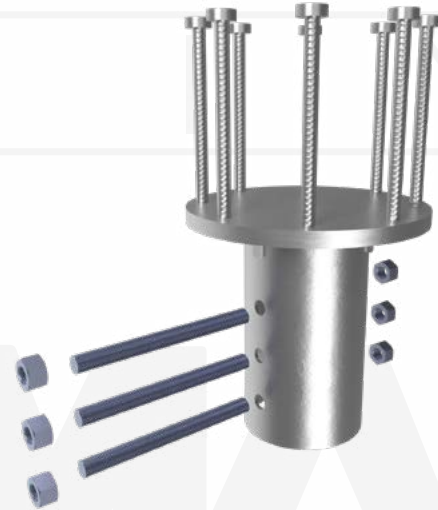

A - As Required for Shear (Min. 4" per IBC)
B - As required for Compression
C - Min. 3" per IBC

MAGNUM
PIERING
designed to support

156 Circle Freeway Dr.
Cincinnati, OH 45246
800-822-7437
www.MagnumPiering.com

MAGNUM® MHC1698-16T24S215B3 Rebar Plate Cap

ASD: 407 Kips Comp. / 281.8 Kips Tens.* / 128.7 Kip-ft Moment*

24" Dia. x 1-1/2" Bearing Plate w/ (8) #9 Headed Rebar Studs & 16-1/8" I.D. Collar
Fits MH1650-6 Helical Piles

Description: MAGNUM® Rebar Plate Caps provide superior embedment in concrete pile caps. Utilizing rigid bolted couplings to connect to helical screw piles and headed rebar studs to transfer tension and moment from the concrete pile cap into the pile. MAGNUM® products are manufactured in the USA according to our ISO 9001 approved Quality Program. Structural capacities are developed according to AISC 360 and ACI 318 considering an average design life of 75 years for bare steel in most soil conditions. Hot-dip galvanizing is available upon request. Design and detailing of the structure to which rebar plate cap is embedded in varies by project and is the responsibility of the registered design professional.

Specifications	
Collar Tube	17" O.D. ASTM A252, Fy = 80 ksi min.
End Effector	24" Diameter x 1-1/2" Steel Bearing Plate w/ (8) #9 Headed Rebar Studs, ASTM A706
Pile Connection	(3) 1-1/2" ASTM A193 B7 Threaded Rod Zinc Coated to ASTM B695/F1941 when used with Galvanized Piles
Coating	Bare Steel (NG), Galvanized per ASTM A153/A123 (G)
Compatibility	MH1650-6
Capacity	
Allowable Compression	407 Kips
*Maximum Allowable Tension	281.8 Kips
*Maximum Allowable Moment	128.7 Kip-Ft

*Tension & Moment capacity are interactive. Utilize the Combined Loading Chart below.

Notes: Cap capacity is developed using the ASD design method and considers strength of collar, end effector, and pile connection. Rebar studs conform to ACI 318 dimensions and are designed to have full tension development in normal weight concrete with 28-day $f'c \geq 3,000$ psi. Capacity may be limited by the helical pile, bearing/pullout capacity of soil, or strength of the concrete the cap is embedded in.

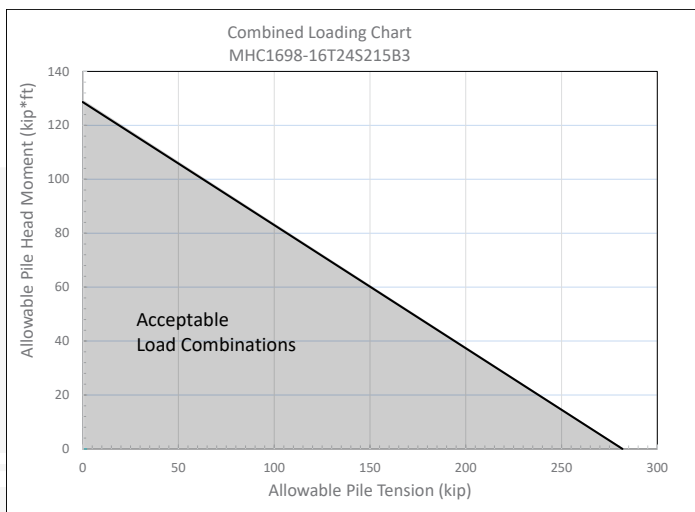

Installation Notes: After installation of a MAGNUM® Helical Pile to the correct depth, torque, and capacity, cut-off the pile shaft at the proper elevation. Drill (3) 1-9/16" thru holes using a MAGNUM® drill template, place the cap over the shaft and secure with (3) 1-1/2" bolts. Ensure direct bearing of plate on shaft. Snug tighten nut. Place reinforcing steel, cast concrete and consolidate around the pile cap per project requirements.



Rebar Caps

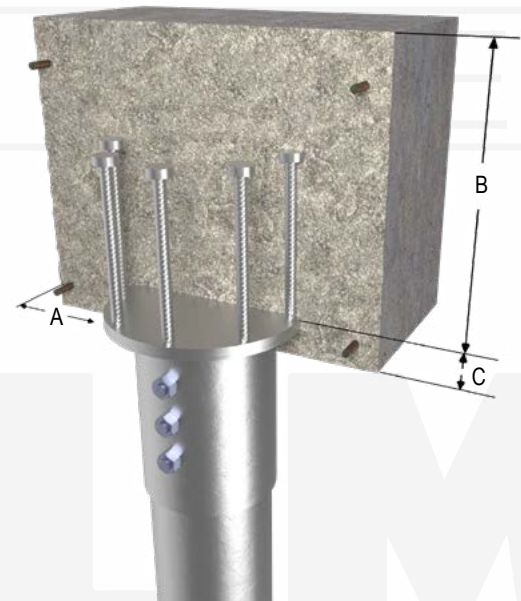

- A - As Required for Shear (Min. 4" per IBC)
- B - As required for Compression
- C - Min. 3" per IBC



156 Circle Freeway Dr.
Cincinnati, OH 45246
800-822-7437

www.MagnumPiering.com

MAGNUM® MHC16912-18R25S226B3 Rebar Plate Cap

ASD: 568.7 Kips Comp. / 281.8 Kips Tens.* / 203.1 Kip-ft Moment*

25" Dia. x 1-1/4" Bearing Plate w/ (12) #9 Headed Rebar Studs & 19" I.D. Collar
Fits MH1843-6 Helical Piles

Description: MAGNUM® Rebar Plate Caps provide superior embedment in concrete pile caps. Utilizing rigid bolted couplings to connect to helical screw piles and headed rebar studs to transfer tension and moment from the concrete pile cap into the pile. MAGNUM® products are manufactured in the USA according to our ISO 9001 approved Quality Program. Structural capacities are developed according to AISC 360 and ACI 318 considering an average design life of 75 years for bare steel in most soil conditions. Hot-dip galvanizing is available upon request. Design and detailing of the structure to which rebar plate cap is embedded in varies by project and is the responsibility of the registered design professional.

Specifications	
Collar Tube	20" O.D. ASTM A252, Fy = 50 ksi min.
End Effector	25" Diameter x 1-1/4" Steel Bearing Plate w/ (12) #9 Headed Rebar Studs, ASTM A706
Pile Connection	(3) 1-1/2" ASTM A193 B7 Threaded Rod Zinc Coated to ASTM B695/F1941 when used with Galvanized Piles
Coating	Bare Steel (NG), Galvanized per ASTM A153/A123 (G)
Compatibility	MH1843-6
Capacity	
Allowable Compression	568.7 Kips
*Maximum Allowable Tension	281.8 Kips
*Maximum Allowable Moment	203.1 Kip-Ft

*Tension & Moment capacity are interactive. Utilize the Combined Loading Chart below.

Notes: Cap capacity is developed using the ASD design method and considers strength of collar, end effector, and pile connection. Rebar studs conform to ACI 318 dimensions and are designed to have full tension development in normal weight concrete with 28-day $f_c \geq 3,000$ psi. Capacity may be limited by the helical pile, bearing/pullout capacity of soil, or strength of the concrete the cap is embedded in.

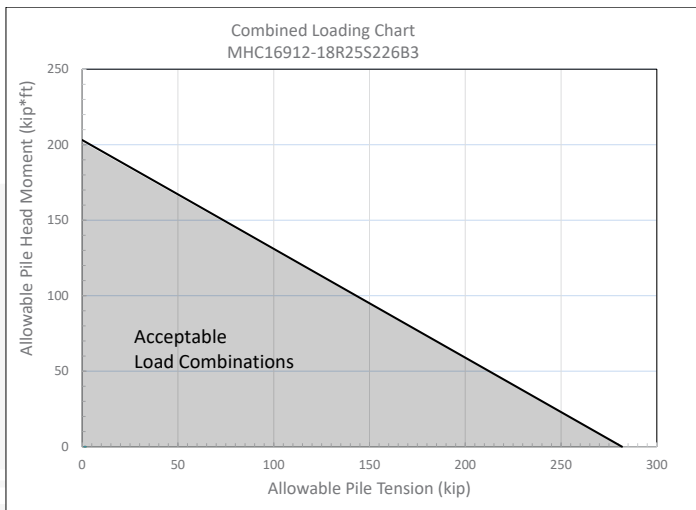

Installation Notes: After installation of a MAGNUM® Helical Pile to the correct depth, torque, and capacity, cut-off the pile shaft at the proper elevation. Drill (3) 1-9/16" thru holes using a MAGNUM® drill template, place the cap over the shaft and secure with (3) 1-1/2" bolts. Ensure direct bearing of plate on shaft. Snug tighten nut. Place reinforcing steel, cast concrete and consolidate around the pile cap per project requirements.

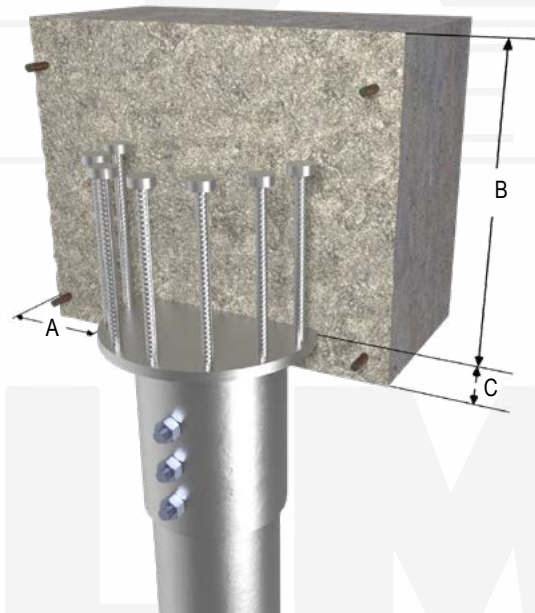

A - As Required for Shear (Min. 4" per IBC)
B - As required for Compression
C - Min. 3" per IBC

MAGNUM
PIERING
designed to support

156 Circle Freeway Dr.
Cincinnati, OH 45246
800-822-7437
www.MagnumPiering.com

MAGNUM® MHC1082-3BR1 Adjustable Plate Cap

Allowable Capacity 17 Tons Compression / 17 Tons Tension

12"Ø x 1/2" Bearing Plate & 3.13-Inch I.D. Collar
Fits MH325BR(-6) Helical Piles

Description: MAGNUM® Adjustable Plate Caps consist of a collar tube with a bolt hole for connection to MAGNUM® helical piles and a circular bearing plate secured to a large diameter threaded bar that allows up to 3-1/2" of vertical adjustment. The unique design of this cap allows it to be used in applications where lateral loads and/or bending will be applied to the top of the pile, which can only be resisted by the strength of an equally rigid thread bar. MAGNUM® products are manufactured in the USA according to our ISO 9001 approved quality program. Structural capacities are developed according to AISC 360 considering an average design life of 75 years for bare steel in most soil conditions. Hot-dip galvanizing is available upon request. Design and detailing of the structure, to which bearing plate cap is attached varies by project and is the responsibility of the registered design professional.

Specifications	
Collar Tube	0.31" x 3.13" I.D. ASTM A513, Fy = 65 ksi or Better
End Effector	12"Ø x 1/2" Steel Bearing Plate with 3.0" Ø Thread Bar
Pile Connection	(1) 1" SAE J429 Grade 8 Zinc Coated to ASTM B695/F1941
Coating	Spray Galvanized per ASTM A780 (SG), Bare Steel (NG), or Epoxy Coated per ICC-ES AC228 (EP)
Compatibility	MH325BR(-6)
Capacity	
Ultimate Compression/Tension	35 Tons / 35 Tons
Allowable Compression/Tension	17 Tons / 17 Tons

Notes: Cap capacity is developed using the ASD design method and considers strength of collar, end effector, and pile connection. Capacity may be limited by the helical pile itself, bearing/pullout capacity of soil, or strength of the structure to which the cap is attached.



Direct Connect

Installation Notes: After installation of a MAGNUM® Helical Pile to the correct depth, torque, and capacity cut off the pile at the proper elevation; note pile must be set at +0"/-3.5" from planned elevation. If pile shaft is set higher than this elevation range due to reaching maximum torque or refusal, stop installation and cut-off the pile shaft at the proper elevation. Drill (1) 1-1/16" diameter hole through the shaft using a MAGNUM® drill template, place the cap over the shaft and secure with (1) 1" bolt. Snug tighten nut. Adjust to final elevation by turning plate as required. Tighten set screw to prevent wobble. Place steel beam/post on cap and weld or secure as required for the project.

MAGNUM
PIERING
designed to support

156 Circle Freeway Dr.
Cincinnati, OH 45246
800-822-7437

www.MagnumPiering.com

MAGNUM® MHC1082-4B2 Adjustable Plate Cap

Allowable Capacity 20 Tons Compression / 20 Tons Tension

14"Ø x 5/8" Bearing Plate & 4.63-Inch I.D. Collar

Fits MH429 & MH434 Helical Piles

Description: MAGNUM® Adjustable Plate Caps consist of a collar tube with a bolt hole for connection to MAGNUM® helical piles and a circular bearing plate secured to a large diameter threaded bar that allows up to 3-1/2" of vertical adjustment. The unique design of this cap allows it to be used in applications where lateral loads and/or bending will be applied to the top of the pile, which can only be resisted by the strength of an equally rigid thread bar. MAGNUM® products are manufactured in the USA according to our ISO 9001 approved quality program. Structural capacities are developed according to AISC 360 considering an average design life of 75 years for bare steel in most soil conditions. Hot-dip galvanizing is available upon request. Design and detailing of the structure, to which bearing plate cap is attached varies by project and is the responsibility of the registered design professional.

Specifications	
Collar Tube	0.31" x 4.63" I.D. ASTM A513, Fy = 65 ksi or Better
End Effector	14"Ø x 5/8" Steel Bearing Plate with 3.0"Ø Thread Bar
Pile Connection	(1) 1-1/4" SAE J429 Grade 5 Zinc Coated to ASTM B695/F1941
Coating	Spray Galvanized per ASTM A780 (SG), Bare Steel (NG), or Epoxy Coated per ICC-ES AC228 (EP)
Compatibility	MH429(-6), MH434(-6)
Capacity	
Ultimate Compression/ Tension	40 Tons / 40 Tons
Allowable Compression/ Tension	20 Tons / 20 Tons

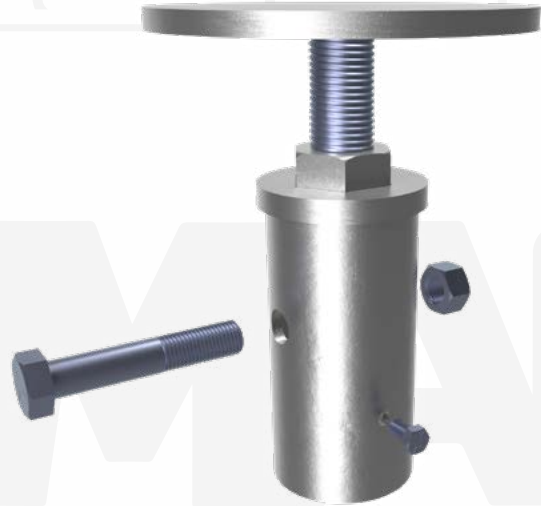

Notes: Cap capacity is developed using the ASD design method and considers strength of collar, end effector, and pile connection. Capacity may be limited by the helical pile itself, bearing/pullout capacity of soil, or strength of the structure to which the cap is attached.

Installation Notes: After installation of a MAGNUM® Helical Pile to the correct depth, torque, and capacity cut off the pile at the proper elevation; note pile must be set at +0"/-3.5" from planned elevation. If pile shaft is set higher than this elevation range due to reaching maximum torque or refusal, stop installation and cut-off the pile shaft at the proper elevation. Drill (1) 1-5/16" diameter hole through the shaft using a MAGNUM® drill template, place the cap over the shaft and secure with (1) 1-1/4" bolt. Snug tighten nut. Adjust to final elevation by turning plate as required. Tighten set screw to prevent wobble. Place steel beam/post on cap and weld or secure as required for the project.



MAGNUM®
PIERING
designed to support

156 Circle Freeway Dr.
Cincinnati, OH 45246
800-822-7437
www.MagnumPiering.com

MAGNUM® MHC1082-5O16B1 Adjustable Plate Cap

Allowable Capacity 27.5 Tons Compression / 21 Tons Tension

16"Ø x 7/8" Bearing Plate & 5.75-Inch I.D. Collar
Fits MH530, MH536, MH542 & MH547 Helical Piles

Description: MAGNUM® Adjustable Plate Caps consist of a collar tube with a bolt hole for connection to MAGNUM® helical piles and a circular bearing plate secured to a large diameter threaded bar that allows up to 3-1/2" of vertical adjustment. The unique design of this cap allows it to be used in applications where lateral loads and/or bending will be applied to the top of the pile, which can only be resisted by the strength of an equally rigid thread bar. MAGNUM® products are manufactured in the USA according to our ISO 9001 approved quality program. Structural capacities are developed according to AISC 360 considering an average design life of 75 years for bare steel in most soil conditions. Hot-dip galvanizing is available upon request. Design and detailing of the structure, to which bearing plate cap is attached varies by project and is the responsibility of the registered design professional..

Specifications	
Collar Tube	0.44" x 5.75" I.D. ASTM A252, Fy = 70 ksi or Better
End Effector	16"Ø x 7/8" Steel Bearing Plate with 3.0"Ø Thread Bar
Pile Connection	(1) 1-1/2" SAE J429 Grade 5 Zinc Coated to ASTM B695/F1941
Coating	Spray Galvanized per ASTM A780 (SG), Bare Steel (NG), or Epoxy Coated per ICC-ES AC228 (EP)
Compatibility	MH530-6, MH536-6, MH542-6, MH547-6
Capacity	
Ultimate Compression/ Tension	55 Tons / 42 Tons
Allowable Compression/ Tension	27.5 Tons / 21 Tons

Notes: Cap capacity is developed using the ASD design method and considers strength of collar, end effector, and pile connection. Capacity may be limited by the helical pile itself, bearing/pullout capacity of soil, or strength of the structure to which the cap is attached.

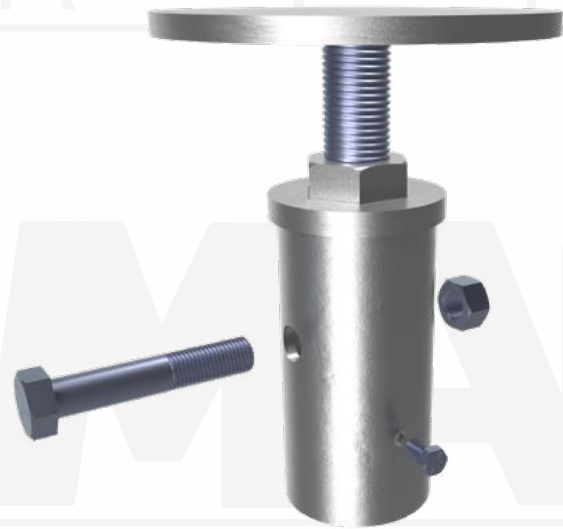

Direct Connect

Installation Notes: After installation of a MAGNUM® Helical Pile to the correct depth, torque, and capacity cut off the pile at the proper elevation; note pile must be set at +0"/-3.5" from planned elevation. If pile shaft is set higher than this elevation range due to reaching maximum torque or refusal, stop installation and cut-off the pile shaft at the proper elevation. Drill (1) 1-9/16" diameter hole through the shaft using a MAGNUM® drill template, place the cap over the shaft and secure with (1) 1-1/2" bolt. Snug tighten nut. Adjust to final elevation by turning plate as required. Tighten set screw to prevent wobble. Place steel beam/post on cap and weld or secure as required for the project.



156 Circle Freeway Dr.
Cincinnati, OH 45246
800-822-7437
www.MagnumPiering.com

MAGNUM® MHC1304-3N12BR2 Circular Plate Cap

Allowable Capacity 19 Tons Compression / 23 Tons Tension

12"Ø x 3/4" Bearing Plate with (1)#10 Nut & 3.13-Inch I.D. Collar
Fits MH325BR(-6) Helical Piles

Description: MAGNUM® Circular Plate Caps consist of a collar tube with bolt holes for connection to MAGNUM® helical piles and a circular bearing plate with an integrated nut. MAGNUM® products are manufactured in the USA according to our ISO 9001 approved quality program. Structural capacities are developed according to AISC 360 considering an average design life of 75 years for hot-dip galvanized steel in most soil conditions. Bare steel is available upon request. Design and detailing of the structure, to which bearing plate cap is attached varies by project and is the responsibility of the registered design professional.

Specifications	
Collar Tube	0.31" x 3.13" I.D. ASTM A513, Fy = 65 ksi or Better
End Effector	12"Ø x 3/4" Steel Bearing Plate with (1) #10 Nut
Pile Connection	(2) 1" SAE J429 Grade 8 Zinc Coated to ASTM B695/F194
Coating	Galvanized per ASTM A153/A123 (G), Bare Steel (NG), or Epoxy Coated per ICC-ES AC228 (EP)
Compatibility	MH325BR(-6)
Capacity	
Ultimate Compression/ Tension	38 Tons / 46 Tons
Allowable Compression/ Tension	19 Tons / 23 Tons

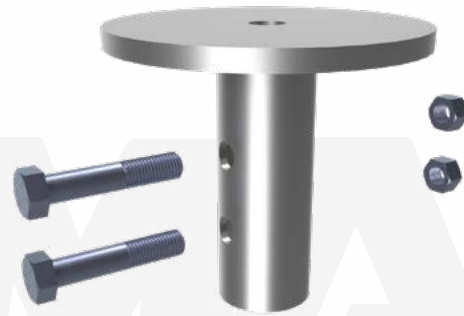

Notes: Cap capacity is developed using the ASD design method and considers strength of collar, end effector, and pile connection. Capacity may be limited by the helical pile itself, bearing/pullout capacity of soil, or strength of the structure to which the cap is attached.



Installation Notes: After installation of a MAGNUM® Helical Pile to the correct depth, torque, and capacity, cut-off the pile shaft at the proper elevation. Drill (2) 1-1/16" holes through the shaft using a MAGNUM® drill template, place the cap over the shaft and secure with (2) 1" bolts. Snug tighten nuts. Alternatively, drilling through pile may be omitted and plug welds may be used to secure cap to pile in place of bolt(s), see MAGNUM® Technical Bulletin TB004. Ensure direct bearing of plate on shaft. Affix the structure to the pile cap by installing a threaded rod through the connection point into the integrated nut in the cap. Connection to structures vary by project, tightness and fit-up requirements are the responsibility of the registered design professional.

MAGNUM®
P I E R I N G
designed to support

156 Circle Freeway Dr.
Cincinnati, OH 45246
800-822-7437
www.MagnumPiering.com

MAGNUM® MHC1304-4O12B2 Circular Plate Cap

Allowable Capacity 46 Tons Compression / 28 Tons Tension

12"Ø x 7/8" Bearing Plate with (1) #10 Nut & 4.63-Inch I.D. Collar
Fits MH429 & MH434 Helical Piles

Description: MAGNUM® Circular Plate Caps consist of a collar tube with bolt holes for connection to MAGNUM® helical piles and a circular bearing plate with an integrated nut. MAGNUM® products are manufactured in the USA according to our ISO 9001 approved quality program. Structural capacities are developed according to AISC 360 considering an average design life of 75 years for hot-dip galvanized steel in most soil conditions. Bare steel is available upon request. Design and detailing of the structure, to which bearing plate cap is attached varies by project and is the responsibility of the registered design professional.

Specifications	
Collar Tube	0.31" x 4.63" I.D. ASTM A252, Fy = 65 ksi or Better
End Effector	12"Ø x 7/8" Steel Bearing Plate with (1) #10 Nut
Pile Connection	(2) 1-1/4" SAE J429 Grade 5 Zinc Coated to ASTM B695/F194
Coating	Galvanized per ASTM A153/A123 (G), Bare Steel (NG), or Epoxy Coated per ICC-ES AC228 (EP)
Compatibility	MH429(-6), MH434(-6)
Capacity	
Ultimate Compression/ Tension	91 Tons / 56 Tons
Allowable Compression/ Tension	46 Tons / 28 Tons

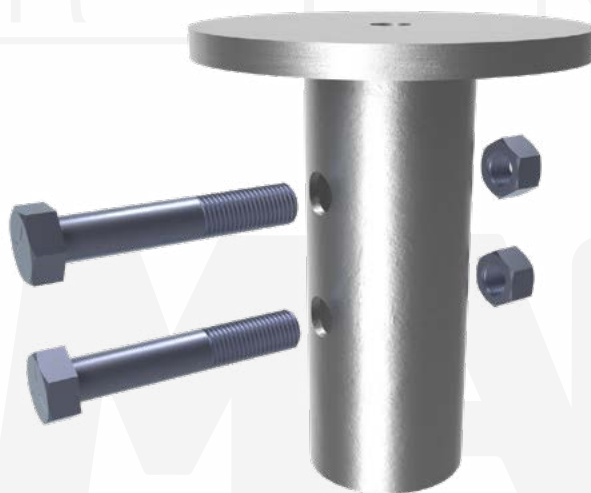

Direct Connect

Notes: Cap capacity is developed using the ASD design method and considers strength of collar, end effector, and pile connection. Capacity may be limited by the helical pile itself, bearing/pullout capacity of soil, or strength of the structure to which the cap is attached.



Installation Notes: After installation of a MAGNUM® Helical Pile to the correct depth, torque, and capacity, cut-off the pile shaft at the proper elevation. Drill (2) 1-5/16" holes through the shaft using a MAGNUM® drill template, place the cap over the shaft and secure with (2) 1-1/4" bolts. Snug tighten nuts. Alternatively, drilling through pile may be omitted and plug welds may be used to secure cap to pile in place of bolt(s), see MAGNUM® Technical Bulletin TB004. Ensure direct bearing of plate on shaft. Affix the structure to the pile cap by installing a threaded rod through the connection point into the integrated nut in the cap. Connection to structures vary by project, tightness and fit-up requirements are the responsibility of the registered design professional.

U.S. Patent 9,365,998



156 Circle Freeway Dr.
Cincinnati, OH 45246
800-822-7437
www.MagnumPiering.com

MAGNUM® MHC1304-5O12B2 Circular Plate Cap

Allowable Capacity 74 Tons Compression / 28 Tons Tension

12"Ø x 7/8" Bearing Plate with (1) #10 Nut & 5.75-Inch I.D. Collar

Fits MH530, MH536, MH542 & MH547 Helical Piles

Description: MAGNUM® Circular Plate Caps consist of a collar tube with bolt holes for connection to MAGNUM® helical piles and a circular bearing plate with an integrated nut. MAGNUM® products are manufactured in the USA according to our ISO 9001 approved quality program. Structural capacities are developed according to AISC 360 considering an average design life of 75 years for hot-dip galvanized steel in most soil conditions. Bare steel is available upon request. Design and detailing of the structure, to which bearing plate cap is attached varies by project and is the responsibility of the registered design professional.

Specifications	
Collar Tube	0.44" x 5.75" I.D. ASTM A252, Fy = 70 ksi or Better
End Effector	12"Ø x 7/8" Steel Bearing Plate with (1) #10 Nut
Pile Connection	2) 1-1/2" SAE J429 Grade 5 Zinc Coated to ASTM B695/F194
Coating	Galvanized per ASTM A153/A123 (G), Bare Steel (NG), or Epoxy Coated per ICC-ES AC228 (EP)
Compatibility	MH530-6, MH536-6, MH542-6, MH547-6
Capacity	
Ultimate Compression/ Tension	148 Tons / 56 Tons
Allowable Compression/ Tension	74 Tons / 28 Tons

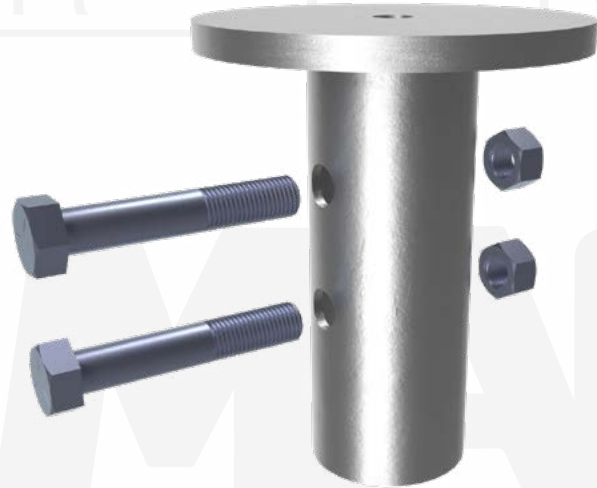

Notes: Cap capacity is developed using the ASD design method and considers strength of collar, end effector, and pile connection. Capacity may be limited by the helical pile itself, bearing/pullout capacity of soil, or strength of the structure to which the cap is attached.



Installation Notes: After installation of a MAGNUM® Helical Pile to the correct depth, torque, and capacity, cut-off the pile shaft at the proper elevation. Drill (2) 1-9/16" holes through the shaft using a MAGNUM® drill template, place the cap over the shaft and secure with (2) 1-1/2" bolts. Snug tighten nuts. Alternatively, drilling through pile may be omitted and plug welds may be used to secure cap to pile in place of bolt(s), see MAGNUM® Technical Bulletin TB004. Ensure direct bearing of plate on shaft. Affix the structure to the pile cap by installing a threaded rod through the connection point into the integrated nut in the cap. Connection to structures vary by project, tightness and fit-up requirements are the responsibility of the registered design professional.

U.S. Patent 9,365,998

MAGNUM®
P I E R I N G
designed to support

156 Circle Freeway Dr.
Cincinnati, OH 45246
800-822-7437
www.MagnumPiering.com

MAGNUM® MHC1350-5N6135B1 Gusseted Cap

Allowable Capacity 98 Tons Compression / 33 Tons Tension

6" x 13-1/2" x 3/4" Bearing Plate & 5.75-Inch I.D. Collar
 Fits MH530, MH536, MH542 & MH547 Helical Piles

Description: MAGNUM® Gusseted Plate Caps consist of a collar tube with a bolt hole for connection to MAGNUM® helical piles and a stiffened steel bearing plate. MAGNUM® products are manufactured in the USA according to our ISO 9001 approved quality program. Structural capacities are developed according to AISC 360 considering an average design life of 75 years for bare steel in most soil conditions. Hot-dip galvanizing is available upon request. Design and detailing of the structure, to which bearing plate cap is attached varies by project and is the responsibility of the registered design professional.

Specifications	
Collar Tube	0.44" x 5.75" I.D. ASTM A252, Fy = 70 ksi or Better
End Effector	6" x 13-1/2" x 3/4" Steel Bearing Plate with Support Gussets
Pile Connection	(1) 1-1/2" SAE J429 Grade 5 Zinc Coated to ASTM B695/F1941
Coating	Galvanized per ASTM A153/A123 (G), Bare Steel (NG), or Epoxy Coated per ICC-ES AC228 (EP)
Compatibility	MH530-6, MH536-6, MH542-6, MH547-6
Capacity	
Ultimate Compression/Tension	195 Tons / 65 Tons
Allowable Compression/Tension	98 Tons / 33 Tons



Direct Connect

Notes: Cap capacity is developed using the ASD design method and considers strength of collar, end effector, and pile connection. Capacity may be limited by the helical pile itself, bearing/pullout capacity of soil, or strength of the structure to which the cap is attached.

Installation Notes: After installation of a MAGNUM® Helical Pile to the correct depth, torque, and capacity, cut-off the pile shaft at the proper elevation. Drill (1) 1-9/16" hole through the shaft using a MAGNUM® drill template, place the cap over the shaft and secure with (1) 1-1/2" bolt. Snug tighten nuts. Alternatively, drilling through pile may be omitted and plug welds may be used to secure cap to pile in place of bolt(s), see MAGNUM® Technical Bulletin TB004. Ensure direct bearing of plate on shaft.



156 Circle Freeway Dr.
 Cincinnati, OH 45246
 800-822-7437
www.MagnumPiering.com

MAGNUM® MHC1350-5N6135B3 Gusseted Cap

Allowable Capacity 98 Tons Compression / 83 Tons Tension

6" x 13-1/2" x 3/4" Bearing Plate & 5.75-Inch I.D. Collar
 Fits MH530, MH536, MH542 & MH547 Helical Piles

Description: MAGNUM® Gusseted Plate Caps consist of a collar tube with a bolt holes for connection to MAGNUM® helical piles and a stiffened steel bearing plate. MAGNUM® products are manufactured in the USA according to our ISO 9001 approved quality program. Structural capacities are developed according to AISC 360 considering an average design life of 75 years for bare steel in most soil conditions. Hot-dip galvanizing is available upon request. Design and detailing of the structure, to which bearing plate cap is attached varies by project and is the responsibility of the registered design professional.

Specifications	
Collar Tube	0.44" x 5.75" I.D. ASTM A252, Fy = 70 ksi or Better
End Effector	6" x 13-1/2" x 3/4" Steel Bearing Plate with Support Gussets
Pile Connection	(3) 1-1/2" SAE J429 Grade 5 Zinc Coated to ASTM B695/F1941
Coating	Galvanized per ASTM A153/A123 (G), Bare Steel (NG), or Epoxy Coated per ICC-ES AC228 (EP)
Compatibility	MH530-6, MH536-6, MH542-6, MH547-6
Capacity	
Ultimate Compression/ Tension	195 Tons / 165 Tons
Allowable Compression/ Tension	98 Tons / 83 Tons



Notes: Cap capacity is developed using the ASD design method and considers strength of collar, end effector, and pile connection. Capacity may be limited by the helical pile itself, bearing/pullout capacity of soil, or strength of the structure to which the cap is attached.

Installation Notes: After installation of a MAGNUM® Helical Pile to the correct depth, torque, and capacity, cut-off the pile shaft at the proper elevation. Drill (3) 1-9/16" holes through the shaft using a MAGNUM® drill template, place the cap over the shaft and secure with (3) 1-1/2" bolts. Snug tighten nuts. Alternatively, drilling through pile may be omitted and plug welds may be used to secure cap to pile in place of bolt(s), see MAGNUM® Technical Bulletin TB004. Ensure direct bearing of plate on shaft.



156 Circle Freeway Dr.
 Cincinnati, OH 45246
 800-822-7437
www.MagnumPiering.com

MAGNUM® MHC1350-9P24B3 Gusseted Cap

Allowable Capacity 112 Tons Compression / 112 Tons Tension

24" x 24" x 1" Bearing Plate & 9.85-Inch I.D. Collar
Fits MH939 Helical Piles

Description: MAGNUM® Gusseted Plate Caps consist of a collar tube with a bolt holes for connection to MAGNUM® helical piles and a stiffened steel bearing plate. MAGNUM® products are manufactured in the USA according to our ISO 9001 approved quality program. Structural capacities are developed according to AISC 360 considering an average design life of 75 years for bare steel in most soil conditions. Hot-dip galvanizing is available upon request. Design and detailing of the structure, to which bearing plate cap is attached varies by project and is the responsibility of the registered design professional..

Specifications	
Collar Tube	0.45" x 9.85" I.D. ASTM A252, Fy = 65 ksi or Better
End Effector	12" x 12" x 1" Steel Bearing Plate with Support Gussets
Pile Connection	(3) 1-1/2" ASTM A193 B7 Zinc Coated to ASTM B695/F194
Coating	Galvanized per ASTM A153/A123 (G), Bare Steel (NG), or Epoxy Coated per ICC-ES AC228 (EP)
Compatibility	MH939-6
Capacity	
Ultimate Compression/ Tension	224 Tons / 224 Tons
Allowable Compression/ Tension	112 Tons / 112 Tons

Notes: Cap capacity is developed using the ASD design method and considers strength of collar, end effector, and pile connection. Capacity may be limited by the helical pile itself, bearing/pullout capacity of soil, or strength of the structure to which the cap is attached.



Direct Connect



Installation Notes: After installation of a MAGNUM® Helical Pile to the correct depth, torque, and capacity, cut-off the pile shaft at the proper elevation. Drill (3) 1-9/16" holes through the shaft using a MAGNUM® drill template, place the cap over the shaft and secure with (3) 1-1/2" bolts. Snug tighten nuts. Alternatively, drilling through pile may be omitted and plug welds may be used to secure cap to pile in place of bolt(s), see MAGNUM® Technical Bulletin TB004. Ensure direct bearing of plate on shaft.



156 Circle Freeway Dr.
Cincinnati, OH 45246
800-822-7437
www.MagnumPiering.com

MAGNUM® MHC1415-3O1010B Tilted Plate Cap

Allowable Capacity 16 Tons Compression / 16 Tons Tension

10" x 10" x 7/8" Bearing Plate Tilted 15° & 3.13-Inch I.D. Collar

Fits MH313B, MH313BR & MH325B Helical Piles

Description: MAGNUM® Tilted Plate Caps consist of a collar tube with bolt holes for connection to MAGNUM® helical piles and tilted steel bearing plate. MAGNUM® products are manufactured in the USA according to our ISO 9001 approved quality program. Structural capacities are developed according to AISC 360 considering an average design life of 75 years for bare steel in most soil conditions. Hot-dip galvanizing is available upon request. Design and detailing of the structure, to which bearing plate cap is attached varies by project and is the responsibility of the registered design professional.

Specifications	
Collar Tube	0.25" x 3.13" I.D. ASTM A513, Fy = 65 ksi or Better
End Effector	10" x 10" x 7/8" Steel Bearing Plate Tilted 15°
Pile Connection	(1) 7/8" SAE J429 Grade 5 Zinc Coated to ASTM B695/F1941
Coating	Galvanized per ASTM A153/A123 (G), Bare Steel (NG), or Epoxy Coated per ICC-ES AC228 (EP)
Compatibility	MH313B, MH313BR, MH325B
Capacity	
Ultimate Compression/ Tension	32 Tons / 32 Tons
Allowable Compression/ Tension	16 Tons / 16 Tons

Notes: Cap capacity is developed using the ASD design method and considers strength of collar, end effector, and pile connection. Capacity may be limited by the helical pile itself, bearing/pullout capacity of soil, or strength of the structure to which the cap is attached.



Installation Notes: After installation of a MAGNUM® Helical Pile to the correct depth, torque, and capacity, cut-off the pile shaft at the proper elevation. Drill (1) 15/16" hole through the shaft using a MAGNUM® drill template, place the cap over the shaft and secure with (1) 7/8" bolt. Snug tighten nut(s). Alternatively, drilling through pile may be omitted and plug welds may be used to secure cap to pile in place of bolt(s), see MAGNUM® Technical Bulletin TB004. Ensure plate is level prior to drilling through shaft or plug welding cap connection.



MAGNUM®
P I E R I N G
designed to support

156 Circle Freeway Dr.
Cincinnati, OH 45246
800-822-7437
www.MagnumPiering.com

MAGNUM® MHC1420-3N11BR1 Tilted Plate Cap

Allowable Capacity 25 Tons Compression / 18 Tons Tension

11"Ø x 3/4" Bearing Plate Tilted 20° & 3.13-Inch I.D. Collar
 Fits MH325BR(-6) Helical Piles

Description: MAGNUM® Tilted Plate Caps consist of a collar tube with bolt holes for connection to MAGNUM® helical piles and tilted steel bearing plate. MAGNUM® products are manufactured in the USA according to our ISO 9001 approved quality program. Structural capacities are developed according to AISC 360 considering an average design life of 75 years for bare steel in most soil conditions. Hot-dip galvanizing is available upon request. Design and detailing of the structure, to which bearing plate cap is attached varies by project and is the responsibility of the registered design professional.

Specifications	
Collar Tube	0.31" x 3.13" I.D. ASTM A513, Fy = 65 ksi or Better
End Effector	11"Ø x 3/4" Steel Bearing Plate Tilted 20°
Pile Connection	(1) 1" SAE J429 Grade 8 Zinc Coated to ASTM B695/F1941
Coating	Galvanized per ASTM A153/A123 (G), Bare Steel (NG), or Epoxy Coated per ICC-ES AC228 (EP)
Compatibility	MH325BR(-6)
Capacity	
Ultimate Compression/ Tension	50 Tons / 36 Tons
Allowable Compression/ Tension	25 Tons / 18 Tons

Notes: Cap capacity is developed using the ASD design method and considers strength of collar, end effector, and pile connection. Capacity may be limited by the helical pile itself, bearing/pullout capacity of soil, or strength of the structure to which the cap is attached.

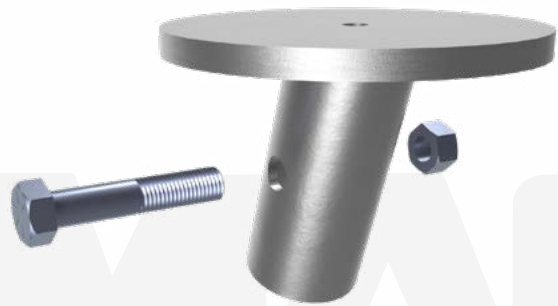
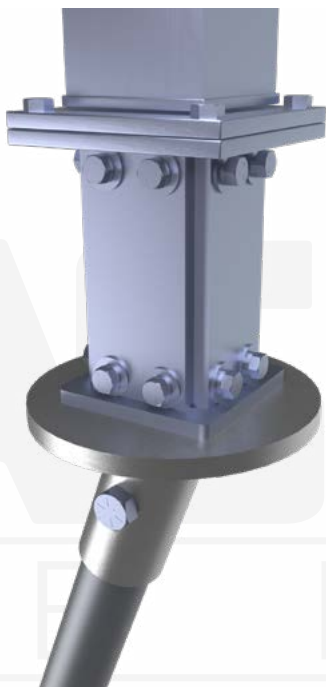

Direct Connect

Installation Notes: After installation of a MAGNUM® Helical Pile to the correct depth, torque, and capacity, cut-off the pile shaft at the proper elevation. Drill (1) 1-1/16" hole through the shaft using a MAGNUM® drill template, place the cap over the shaft and secure with (1) 1" bolt. Snug tighten nut(s). Alternatively, drilling through pile may be omitted and plug welds may be used to secure cap to pile in place of bolt(s), see MAGNUM® Technical Bulletin TB004. Ensure plate is level prior to drilling through shaft or plug welding cap connection.

U.S. Patent 9,365,998



156 Circle Freeway Dr.
 Cincinnati, OH 45246
 800-822-7437
www.MagnumPiering.com

MAGNUM® MHC1420-3N1212BR2 Tilted Plate Cap

Allowable Capacity 25 Tons Compression / 25 Tons Tension

12" x 12" x 3/4" Bearing Plate Tilted 20° & 3.13-Inch I.D. Collar
Fits MH325BR(-6) Helical Piles

Description: MAGNUM® Tilted Plate Caps consist of a collar tube with bolt hole for connection to MAGNUM® helical piles and tilted steel bearing plate. MAGNUM® products are manufactured in the USA according to our ISO 9001 approved quality program. Structural capacities are developed according to AISC 360 considering an average design life of 75 years for bare steel in most soil conditions. Hot-dip galvanizing is available upon request. Design and detailing of the structure, to which bearing plate cap is attached varies by project and is the responsibility of the registered design professional.

Specifications	
Collar Tube	0.31" x 3.13" I.D. ASTM A513, Fy = 65 ksi or Better
End Effector	12" x 12" x 3/4" Steel Bearing Plate Tilted 20°
Pile Connection	(2) 1" SAE J429 Grade 8 Zinc Coated to ASTM B695/F1941
Coating	Galvanized per ASTM A153/A123 (G), Bare Steel (NG), or Epoxy Coated per ICC-ES AC228 (EP)
Compatibility	MH325BR(-6)
Capacity	
Ultimate Compression/ Tension	50 Tons / 50 Tons
Allowable Compression/ Tension	25 Tons / 25 Tons



Notes: Cap capacity is developed using the ASD design method and considers strength of collar, end effector, and pile connection. Capacity may be limited by the helical pile itself, bearing/pullout capacity of soil, or strength of the structure to which the cap is attached.

Installation Notes: After installation of a MAGNUM® Helical Pile to the correct depth, torque, and capacity, cut-off the pile shaft at the proper elevation. Drill (1) 1-1/16" hole through the shaft using a MAGNUM® drill template, place the cap over the shaft and secure with (1) 1" bolt. Snug tighten nut(s). Alternatively, drilling through pile may be omitted and plug welds may be used to secure cap to pile in place of bolt(s), see MAGNUM® Technical Bulletin TB004. Ensure plate is level prior to drilling through shaft or plug welding cap connection.



MAGNUM®
P I E R I N G
designed to support

156 Circle Freeway Dr.
Cincinnati, OH 45246
800-822-7437
www.MagnumPiering.com

MAGNUM® MHC1420-5012B2 Tilted Plate Cap

Allowable Capacity 46 Tons Compression / 33 Tons Tension

12"Ø x 7/8" Bearing Plate Tilted 30° & 5.75-Inch I.D. Collar
 Fits MH530, MH536, MH542 & MH547 Helical Piles

Description: MAGNUM® Tilted Plate Caps consist of a collar tube with bolt holes for connection to MAGNUM® helical piles and tilted steel bearing plate. MAGNUM® products are manufactured in the USA according to our ISO 9001 approved quality program. Structural capacities are developed according to AISC 360 considering an average design life of 75 years for bare steel in most soil conditions. Hot-dip galvanizing is available upon request. Design and detailing of the structure, to which bearing plate cap is attached varies by project and is the responsibility of the registered design professional.

Specifications	
Collar Tube	0.44" x 5.75" I.D. ASTM A252, Fy = 70 ksi or Better
End Effector	12"Ø x 7/8" Steel Bearing Plate Tilted 30°
Pile Connection	(2) 1-1/2" SAE J429 Grade 5 Zinc Coated to ASTM B695/F1941
Coating	Galvanized per ASTM A153/A123 (G), Bare Steel (NG), or Epoxy Coated per ICC-ES AC228 (EP)
Compatibility	MH530-6, MH536-6, MH542-6, MH547-6
Capacity	
Ultimate Compression/ Tension	92 Tons / 66 Tons
Allowable Compression/ Tension	46 Tons / 33 Tons



Direct Connect

Notes: Cap capacity is developed using the ASD design method and considers strength of collar, end effector, and pile connection. Capacity may be limited by the helical pile itself, bearing/pullout capacity of soil, or strength of the structure to which the cap is attached.

Installation Notes: After installation of a MAGNUM® Helical Pile to the correct depth, torque, and capacity, cut-off the pile shaft at the proper elevation. Drill (2) 1-9/16" hole through the shaft using a MAGNUM® drill template, place the cap over the shaft and secure with (2) 1-1/2" bolt. Snug tighten nut(s). Alternatively, drilling through pile may be omitted and plug welds may be used to secure cap to pile in place of bolt(s), see MAGNUM® Technical Bulletin TB004. Ensure plate is level prior to drilling through shaft or plug welding cap connection.



156 Circle Freeway Dr.
 Cincinnati, OH 45246
 800-822-7437
www.MagnumPiering.com

MAGNUM® MHC1430-4O12B2 Circular Plate Cap

Allowable Capacity 46 Tons Compression / 33 Tons Tension

12"Ø x 7/8" Bearing Plate Tilted 30° & 4.63-Inch I.D. Collar

Fits MH429 & MH434 Helical Piles

Description: MAGNUM® Tilted Plate Caps consist of a collar tube with bolt holes for connection to MAGNUM® helical piles and tilted steel bearing plate. MAGNUM® products are manufactured in the USA according to our ISO 9001 approved quality program. Structural capacities are developed according to AISC 360 considering an average design life of 75 years for bare steel in most soil conditions. Hot-dip galvanizing is available upon request. Design and detailing of the structure, to which bearing plate cap is attached varies by project and is the responsibility of the registered design professional.

Specifications	
Collar Tube	0.31" x 4.63" I.D. ASTM A252, Fy = 65 ksi or Better
End Effector	12"Ø x 7/8" Steel Bearing Plate Tilted 30°
Pile Connection	(2) 1-1/4" SAE J429 Grade 5 Zinc Coated to ASTM B695/F1941
Coating	Galvanized per ASTM A153/A123 (G), Bare Steel (NG), or Epoxy Coated per ICC-ES AC228 (EP)
Compatibility	MH429(-6), MH434(-6)
Capacity	
Ultimate Compression/ Tension	91 Tons / 66 Tons
Allowable Compression/ Tension	46 Tons / 33 Tons

Notes: Cap capacity is developed using the ASD design method and considers strength of collar, end effector, and pile connection. Capacity may be limited by the helical pile itself, bearing/pullout capacity of soil, or strength of the structure to which the cap is attached.

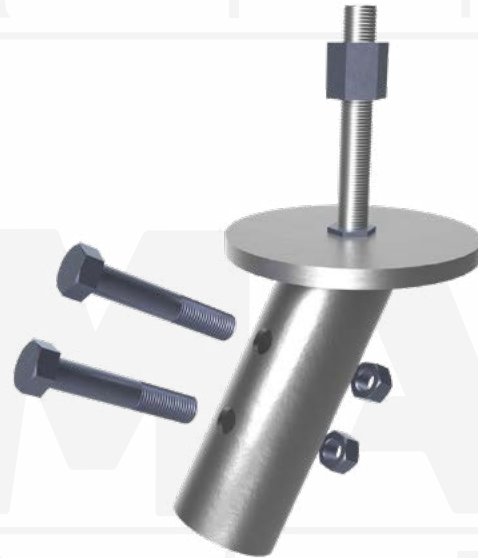

Installation Notes: After installation of a MAGNUM® Helical Pile to the correct depth, torque, and capacity, cut-off the pile shaft at the proper elevation. Drill (2) 1-5/16" hole through the shaft using a MAGNUM® drill template, place the cap over the shaft and secure with (2) 1-1/4" bolt. Snug tighten nut(s). Alternatively, drilling through pile may be omitted and plug welds may be used to secure cap to pile in place of bolt(s), see MAGNUM® Technical Bulletin TB004. Ensure plate is level prior to drilling through shaft or plug welding cap connection.

U.S. Patent 9,365,998

MAGNUM®
P I E R I N G
designed to support

156 Circle Freeway Dr.
Cincinnati, OH 45246
800-822-7437
www.MagnumPiering.com

MAGNUM® MHC1530-3N68B Panel Brace Cap

Allowable Capacity 16 Tons Compression / 12 Tons Tension

6" x 8" x 3/4" Plate Tilted 30° with 3/4" Stud & 3.13-Inch I.D. Collar
 Fits MH325BR(-6) Helical Piles

Description: MAGNUM® Panel Brace Caps consist of a collar tube with bolt holes for connection to MAGNUM® helical piles and tilted steel plate with a 3/4" stud for attachment to common pre-cast concrete or tilt-up panel braces. MAGNUM® products are manufactured in the USA according to our ISO 9001 approved quality program. Structural capacities are developed according to AISC 360 considering an average design life of 75 years for bare steel in most soil conditions. Hot-dip galvanizing is available upon request. Application of the cap varies by project and is the responsibility of registered design professional including brace attachment, brace spacing, and brace height on the wall, as applicable.

Specifications	
Collar Tube	0.25" x 3.13" I.D. ASTM A513, Fy = 65 ksi or Better
End Effector	6" x 8" x 3/4" Steel Bearing Plate Tilted 30° with 3/4" Threaded Attachment Stud
Pile Connection	(1) 7/8" SAE J429 Grade 5 Zinc Coated to ASTM B695/F1941
Coating	Galvanized per ASTM A153/A123 (G), Bare Steel (NG), or Epoxy Coated per ICC-ES AC228 (EP)
Compatibility	MH313B, MH313BR, MH325B
Capacity	
Ultimate Compression/ Tension	32 Tons / 24 Tons
Allowable Compression/ Tension	16 Tons / 12 Tons

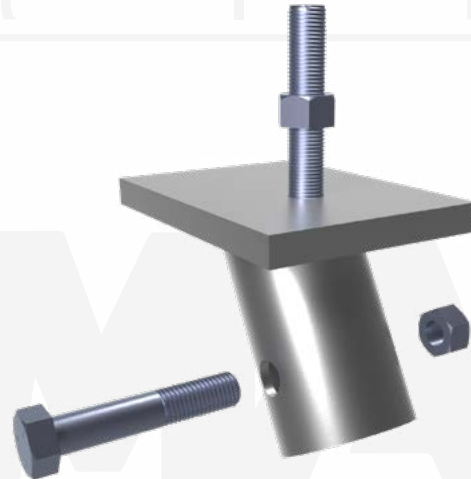

Direct Connect

Notes: Cap capacity is developed using the ASD design method and considers strength of collar, end effector, and pile connection. Capacity may be limited by the helical pile itself, bearing/pullout capacity of soil, or strength of the structure to which the cap is attached.



Installation Notes: After installation of a MAGNUM® Helical Pile to the correct depth, torque, and capacity, cut-off the pile shaft at the proper elevation. Drill (1) 15/16" hole through the shaft using a MAGNUM® drill template, place the cap over the shaft and secure with (1) 7/8" bolt. Snug tighten nut. Alternatively, drilling through pile may be omitted and plug welds may be used to secure cap to pile in place of bolt(s), see MAGNUM® Technical Bulletin TB004. Ensure plate is level prior to drilling through shaft or plug welding cap connection.



156 Circle Freeway Dr.
 Cincinnati, OH 45246
 800-822-7437
www.MagnumPiering.com

MAGNUM® MHC1545-3N68B Panel Brace Cap

Allowable Capacity 16 Tons Compression / 16 Tons Tension

6" x 8" x 3/4" Plate Tilted 45° with 3/4" Stud & 3.13-Inch I.D. Collar
Fits MH313B, MH313BR & MH325B Helical Piles

Description: MAGNUM® Panel Brace Caps consist of a collar tube with bolt holes for connection to MAGNUM® helical piles and tilted steel plate with a 3/4" stud for attachment to common pre-cast concrete or tilt-up panel braces. MAGNUM® products are manufactured in the USA according to our ISO 9001 approved quality program. Structural capacities are developed according to AISC 360 considering an average design life of 75 years for bare steel in most soil conditions. Hot-dip galvanizing is available upon request. Application of the cap varies by project and is the responsibility of registered design professional including brace attachment, brace spacing, and brace height on the wall, as applicable.

Specifications	
Collar Tube	0.25" x 3.13" I.D. ASTM A513, Fy = 65 ksi or Better
End Effector	6" x 8" x 3/4" Steel Bearing Plate Tilted 45° with 3/4" Threaded Attachment Stud
Pile Connection	(1) 7/8" SAE J429 Grade 5 Zinc Coated to ASTM B695/F1941
Coating	Galvanized per ASTM A153/A123 (G), Bare Steel (NG), or Epoxy Coated per ICC-ES AC228 (EP)
Compatibility	MH313B, MH313BR, MH325B
Capacity	
Ultimate Compression/Tension	32 Tons / 32 Tons
Allowable Compression/Tension	16 Tons / 16 Tons

Notes: Cap capacity is developed using the ASD design method and considers strength of collar, end effector, and pile connection. Capacity may be limited by the helical pile itself, bearing/pullout capacity of soil, or strength of the structure to which the cap is attached.

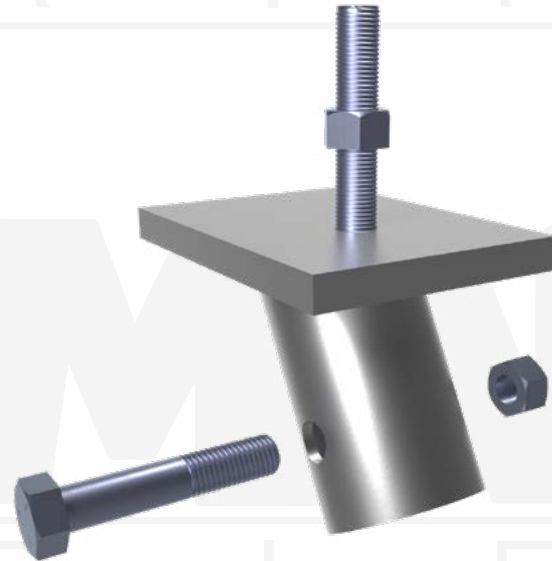

Installation Notes: After installation of a MAGNUM® Helical Pile to the correct depth, torque, and capacity, cut-off the pile shaft at the proper elevation. Drill (1) 15/16" hole through the shaft using a MAGNUM® drill template, place the cap over the shaft and secure with (1) 7/8" bolt. Snug tighten nut. Alternatively, drilling through pile may be omitted and plug welds may be used to secure cap to pile in place of bolt(s), see MAGNUM® Technical Bulletin TB004. Ensure plate is level prior to drilling through shaft or plug welding cap connection.



156 Circle Freeway Dr.
Cincinnati, OH 45246
800-822-7437
www.MagnumPiering.com

MAGNUM® MHC1087-3BR1 Pipe Support Cap

Allowable Capacity 6 Tons Compression / 2.5 Tons Tension

7" x 25" x 1/2" Bearing Plate & 3.13-Inch I.D. Collar
Fits MH325BR(-6) Helical Piles

Description: MAGNUM® Pipe Support Caps consist of a collar tube with a bolt hole for connection to MAGNUM® helical piles and an adapter plate secured to a large diameter threaded bar that allows up to 3" of elevation adjustability and +/-2" of lateral adjustability. The unique design of this cap allows it to be used in pipe support applications where lateral loads will be applied to the top of the pile head, which generally cause bending that can only be resisted by the strength of the large threaded bar. MAGNUM® products are manufactured in the USA according to our ISO 9001 approved quality program. Structural capacities are developed according to AISC 360 considering an average design life of 75 years for spray galvanized steel in most soil conditions. Design and detailing of the piping system to which pipe support caps are attached varies by project and is the responsibility of the registered design professional.

Specifications	
Collar Tube	0.31" x 3.13" I.D. ASTM A513, Fy = 65 ksi or Better
End Effector	7" x 25" x 1/2" Adapter Plate and 0.31 in. x 3.13 in I.D. Sleeve w/ 3.0"Ø Thread Adjustment
Pile Connection	(1) 1" SAE J429 Grade 8 Zinc Coated to ASTM B695/F1941
Coating	Spray Galvanized per ASTM A780 (SG), Bare Steel (NG), or Epoxy Coated per ICC-ES AC228 (EP)
Compatibility	MH325BR(-6)
Capacity	
Ultimate Compression/ Tension	12 Tons / 5 Tons
Allowable Compression/ Tension	6 Tons / 2.5 Tons
Allowable Moment	4.5 kip-ft

Notes: Cap capacity is developed using the ASD design method and considers strength of collar, end effector, and pile connection. Capacity may be limited by the helical pile itself, bearing/pullout capacity of soil, or strength of the structure to which the cap is attached. Allowable moment capacity is excess capacity after maximum eccentricity and lateral loads have been taken into account. Allowable Lateral capacity is the capacity of this cap, actual capacity may be limited by pipe hold down* or total lateral deflection limits.



Pipe Support

Installation Notes: After installation of a MAGNUM® Helical Pile to the correct depth, torque, and capacity cut off the pile at the proper elevation; note pile must be set at +0"/-3.5" from planned elevation. If pile shaft is set higher than this elevation range due to reaching maximum torque or refusal, stop installation and cut-off the pile shaft at the proper elevation. Drill (1) 1-1/16" diameter hole through the shaft using a MAGNUM® drill template, place the cap over the shaft and secure with (1) 1" bolt. Snug tighten nut. Adjust to final elevation by turning plate as required. Tighten set screw to prevent wobble. Place pipe on support and adjust plate as necessary to install the pipe hold down (provided by others).

*Pipe Hold Down: Fits single SAE 'U' bolts for nominal pipe sizes: 4", 5", 6", 8", 10", 12", 14" & 16". Contact Magnum sales team for bolt hole pattern.



Pipe Hold Down Sold Separately



156 Circle Freeway Dr.
Cincinnati, OH 45246
800-822-7437

www.MagnumPiering.com

MAGNUM® MHC1088-3BR1 Pipe Support Cap

Allowable Capacity 6 Tons Compression / 2.5 Tons Tension

7" x 23" x 1/2" Bearing Plate & 3.13-Inch I.D. Collar

Fits MH325BR(-6) Helical Piles

Description: MAGNUM® Pipe Support Caps consist of a collar tube with a bolt hole for connection to MAGNUM® helical piles and an adapter plate secured to a large diameter threaded bar that allows up to 3" of elevation adjustability and +/-2" of lateral adjustability. The unique design of this cap allows it to be used in pipe support applications where lateral loads will be applied to the top of the pile head, which generally cause bending that can only be resisted by the strength of the large threaded bar. MAGNUM® products are manufactured in the USA according to our ISO 9001 approved quality program. Structural capacities are developed according to AISC 360 considering an average design life of 75 years for spray galvanized steel in most soil conditions. Design and detailing of the piping system to which pipe support caps are attached varies by project and is the responsibility of the registered design professional.

Specifications	
Collar Tube	0.31" x 3.13" I.D. ASTM A513, Fy = 65 ksi or Better
End Effector	7" x 23" x 1/2" Adapter Plate and 0.31 in. x 3.13 in I.D. Sleeve w/ 3.0"Ø Thread Adjustment
Pile Connection	(1) 1" SAE J429 Grade 8 Zinc Coated to ASTM B695/F1941
Coating	Spray Galvanized per ASTM A780 (SG), Bare Steel (NG), or Epoxy Coated per ICC-ES AC228 (EP)
Compatibility	MH325BR(-6)
Capacity	
Ultimate Compression/ Tension	12 Tons / 5 Tons
Allowable Compression/ Tension	6 Tons / 2.5 Tons
Allowable Moment	4.5 kip-ft



Notes: Cap capacity is developed using the ASD design method and considers strength of collar, end effector, and pile connection. Capacity may be limited by the helical pile itself, bearing/pullout capacity of soil, or strength of the structure to which the cap is attached. Allowable moment capacity is excess capacity after maximum eccentricity and lateral loads have been taken into account. Allowable Lateral capacity is the capacity of this cap, actual capacity may be limited by pipe hold down* or total lateral deflection limits.

Installation Notes: After installation of a MAGNUM® Helical Pile to the correct depth, torque, and capacity cut off the pile at the proper elevation; note pile must be set at +0"/-3.5" from planned elevation. If pile shaft is set higher than this elevation range due to reaching maximum torque or refusal, stop installation and cut-off the pile shaft at the proper elevation. Drill (1) 1-1/16" diameter hole through the shaft using a MAGNUM® drill template, place the cap over the shaft and secure with (1) 1" bolt. Snug tighten nut. Adjust to final elevation by turning plate as required. Tighten set screw to prevent wobble. Place pipe on support and adjust plate as necessary to install the pipe hold down (provided by others).

*Pipe Hold Down: Fits single SAE 'U' bolts for nominal pipe sizes: 4", 5", 6" & 8". Contact Magnum sales team for bolt hole pattern.



Pipe Hold Down Sold Separately

MAGNUM®
P I E R I N G
designed to support

156 Circle Freeway Dr.
Cincinnati, OH 45246
800-822-7437
www.MagnumPiering.com

MAGNUM® MHC1091-3BR1 Pipe Support Cap

Allowable Capacity 6 Tons Compression / 2.5 Tons Tension

8" x 25" x 5/8" Formed Channel Bearing Plate & 3.13-Inch I.D. Collar
Fits MH325BR(-6) Helical Piles

Description: MAGNUM® Pipe Support Caps consist of a collar tube with a bolt hole for connection to MAGNUM® helical piles and an adapter plate secured to a large diameter threaded bar that allows up to 3" of elevation adjustability and +/-2" of lateral adjustability. The unique design of this cap allows it to be used in pipe support applications where lateral loads will be applied to the top of the pile head, which generally cause bending that can only be resisted by the strength of the large threaded bar. MAGNUM® products are manufactured in the USA according to our ISO 9001 approved quality program. Structural capacities are developed according to AISC 360 considering an average design life of 75 years for spray galvanized steel in most soil conditions. Design and detailing of the piping system to which pipe support caps are attached varies by project and is the responsibility of the registered design professional.

Specifications	
Collar Tube	0.31" x 3.13" I.D. ASTM A513, Fy = 65 ksi or Better
End Effector	8" x 25" x 5/8" Adapter Plate and 0.31 in. x 3.13 in I.D. Sleeve w/ 3.0"Ø Thread Adjustment
Pile Connection	(1) 1" SAE J429 Grade 8 Zinc Coated to ASTM B695/F1941
Coating	Spray Galvanized per ASTM A780 (SG), Bare Steel (NG), or Epoxy Coated per ICC-ES AC228 (EP)
Compatibility	MH325BR(-6)
Capacity	
Ultimate Compression/ Tension	12 Tons / 5 Tons
Allowable Compression/ Tension	6 Tons / 2.5 Tons
Allowable Moment	4.5 kip-ft

Notes: Cap capacity is developed using the ASD design method and considers strength of collar, end effector, and pile connection. Capacity may be limited by the helical pile itself, bearing/pullout capacity of soil, or strength of the structure to which the cap is attached. Allowable moment capacity is excess capacity after maximum eccentricity and lateral loads have been taken into account. Allowable Lateral capacity is the capacity of this cap, actual capacity may be limited by pipe hold down* or total lateral deflection limits.



Pipe Support

Installation Notes: After installation of a MAGNUM® Helical Pile to the correct depth, torque, and capacity cut off the pile at the proper elevation; note pile must be set at +0"/-3.5" from planned elevation. If pile shaft is set higher than this elevation range due to reaching maximum torque or refusal, stop installation and cut-off the pile shaft at the proper elevation. Drill (1) 1-1/16" diameter hole through the shaft using a MAGNUM® drill template, place the cap over the shaft and secure with (1) 1" bolt. Snug tighten nut. Adjust to final elevation by turning plate as required. Tighten set screw to prevent wobble. Place pipe on support and adjust plate as necessary to install the pipe hold down (provided by others).

*Pipe Hold Down: Fits (2) SAE 'U' bolts for nominal pipe sizes: 4", 5", 6", 8", 10", 12", 14" & 16". Contact Magnum sales team for bolt hole pattern.



Pipe Hold Down Sold Separately

MAGNUM
PIERING
designed to support

156 Circle Freeway Dr.
Cincinnati, OH 45246
800-822-7437

www.MagnumPiering.com

MAGNUM® MHC1092-3BR1 Pipe Support Cap

Allowable Capacity 6 Tons Compression / 2.5 Tons Tension

8" x 25" x 5/8" Formed Channel Bearing Plate & 3.13-Inch I.D. Collar
Fits MH325BR(-6) Helical Piles

Description: MAGNUM® Pipe Support Caps consist of a collar tube with a bolt hole for connection to MAGNUM® helical piles and an adapter plate secured to a large diameter threaded bar that allows up to 3" of elevation adjustability and +/-2" of lateral adjustability. The unique design of this cap allows it to be used in pipe support applications where lateral loads will be applied to the top of the pile head, which generally cause bending that can only be resisted by the strength of the large threaded bar. MAGNUM® products are manufactured in the USA according to our ISO 9001 approved quality program. Structural capacities are developed according to AISC 360 considering an average design life of 75 years for spray galvanized steel in most soil conditions. Design and detailing of the piping system to which pipe support caps are attached varies by project and is the responsibility of the registered design professional.

Specifications	
Collar Tube	0.31" x 3.13" I.D. ASTM A513, Fy = 65 ksi or Better
End Effector	8" x 25" x 5/8" Adapter Plate and 0.31 in. x 3.13 in I.D. Sleeve w/ 3.0"Ø Thread Adjustment
Pile Connection	(1) 1" SAE J429 Grade 8 Zinc Coated to ASTM B695/F1941
Coating	Spray Galvanized per ASTM A780 (SG), Bare Steel (NG), or Epoxy Coated per ICC-ES AC228 (EP)
Compatibility	MH325BR(-6)
Capacity	
Ultimate Compression/ Tension	12 Tons / 5 Tons
Allowable Compression/ Tension	6 Tons / 2.5 Tons
Allowable Moment	4.5 kip-ft



Notes: Cap capacity is developed using the ASD design method and considers strength of collar, end effector, and pile connection. Capacity may be limited by the helical pile itself, bearing/pullout capacity of soil, or strength of the structure to which the cap is attached. Allowable moment capacity is excess capacity after maximum eccentricity and lateral loads have been taken into account. Allowable Lateral capacity is the capacity of this cap, actual capacity may be limited by pipe hold down* or total lateral deflection limits.



Pipe Hold Down Sold Separately

Installation Notes: After installation of a MAGNUM® Helical Pile to the correct depth, torque, and capacity cut off the pile at the proper elevation; note pile must be set at +0"/-3.5" from planned elevation. If pile shaft is set higher than this elevation range due to reaching maximum torque or refusal, stop installation and cut-off the pile shaft at the proper elevation. Drill (1) 1-1/16" diameter hole through the shaft using a MAGNUM® drill template, place the cap over the shaft and secure with (1) 1" bolt. Snug tighten nut. Adjust to final elevation by turning plate as required. Tighten set screw to prevent wobble. Place pipe on support and adjust plate as necessary to install the pipe hold down (provided by others).

*Pipe Hold Down: Fits EZ-Line pipe support part #STD-01P & STD-G1 for nominal pipe sizes: 4", 5", 6", 8", 10", 12", 14" & 16". Note: MAGNUM® is not affiliated with EZ Line Pipe Support CO. LLC. Contact Magnum sales team for bolt hole patterns.

MAGNUM®
PIERING
designed to support

156 Circle Freeway Dr.
Cincinnati, OH 45246
800-822-7437
www.MagnumPiering.com

MAGNUM® MHC1093-3BR1 Pipe Support Cap

Allowable Capacity 6 Tons Compression / 2.5 Tons Tension

8" x 25" x 5/8" Formed Channel Bearing Plate & 3.13-Inch I.D. Collar
Fits MH325BR(-6) Helical Piles

Description: MAGNUM® Pipe Support Caps consist of a collar tube with a bolt hole for connection to MAGNUM® helical piles and an adapter plate secured to a large diameter threaded bar that allows up to 3" of elevation adjustability and +/-2" of lateral adjustability. The unique design of this cap allows it to be used in pipe support applications where lateral loads will be applied to the top of the pile head, which generally cause bending that can only be resisted by the strength of the large threaded bar. MAGNUM® products are manufactured in the USA according to our ISO 9001 approved quality program. Structural capacities are developed according to AISC 360 considering an average design life of 75 years for spray galvanized steel in most soil conditions. Design and detailing of the piping system to which pipe support caps are attached varies by project and is the responsibility of the registered design professional.

Specifications	
Collar Tube	0.31" x 3.13" I.D. ASTM A513, Fy = 65 ksi or Better
End Effector	8" x 25" x 5/8" Adapter Plate and 0.31 in. x 3.13 in I.D. Sleeve w/ 3.0"Ø Thread Adjustment
Pile Connection	(1) 1" SAE J429 Grade 8 Zinc Coated to ASTM B695/F1941
Coating	Spray Galvanized per ASTM A780 (SG), Bare Steel (NG), or Epoxy Coated per ICC-ES AC228 (EP)
Compatibility	MH325BR(-6)
Capacity	
Ultimate Compression/ Tension	12 Tons / 5 Tons
Allowable Compression/ Tension	6 Tons / 2.5 Tons
Allowable Moment	4.5 kip-ft

Notes: Cap capacity is developed using the ASD design method and considers strength of collar, end effector, and pile connection. Capacity may be limited by the helical pile itself, bearing/pullout capacity of soil, or strength of the structure to which the cap is attached. Allowable moment capacity is excess capacity after maximum eccentricity and lateral loads have been taken into account. Allowable Lateral capacity is the capacity of this cap, actual capacity may be limited by pipe hold down* or total lateral deflection limits.

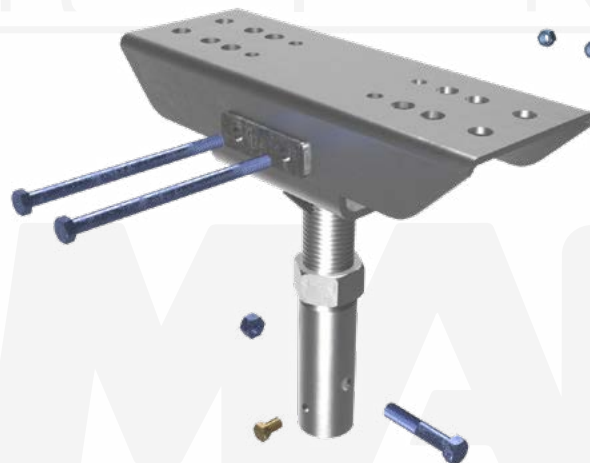

Pipe Support

Installation Notes: After installation of a MAGNUM® Helical Pile to the correct depth, torque, and capacity cut off the pile at the proper elevation; note pile must be set at +0"/-3.5" from planned elevation. If pile shaft is set higher than this elevation range due to reaching maximum torque or refusal, stop installation and cut-off the pile shaft at the proper elevation. Drill (1) 1-1/16" diameter hole through the shaft using a MAGNUM® drill template, place the cap over the shaft and secure with (1) 1" bolt. Snug tighten nut. Adjust to final elevation by turning plate as required. Tighten set screw to prevent wobble. Place pipe on support and adjust plate as necessary to install the pipe hold down (provided by others).

*Pipe Hold Down: Fits EZ-Line pipe support part #SBA-01, CSB-01, GSB-01A&B, PRSB-01, PRSBC-01 &-02 & CSPB-01 for nominal pipe sizes: 3" thru 16". Note: MAGNUM® is not affiliated with EZ Line Pipe Support CO. LLC. Contact Magnum sales team for bolt hole patterns.



Pipe Hold Down Sold Separately



156 Circle Freeway Dr.
Cincinnati, OH 45246
800-822-7437
www.MagnumPiering.com

MAGNUM[®] Bearing Plate Cap

Application Guide for Pile Cap Punching Shear

Structural Plain Concrete

Minimum Concrete Cover to Obtain Rated Capacities for Bearing Plate Caps²

Bearing Plate Cap	2500 psi Concrete		4000 psi Concrete	
	d_c (in)	d_t (in)	d_c (in)	d_t (in)
MHC1000-3B	11	9	10	8
MHC1000-3BR2	11	11	10	10
MSC1300-150M55B	9	8	8	7
MSC1300-175O6565B	11	9	10	8
MHC1300-2K55B1	6	6	6	6
MHC1300-2M55B2	9	6	8	6
MHC1300-3K55B	9	6	8	6
MHC1300-3M66BR1	11	9	10	8
MHC1300-3M6565BR2	11	11	10	10
MHC1300-35L66B1	8	7	7	6
MHC1300-35M66B1	8	7	7	6
MHC1300-4N88B1	14	10	12	9
MHC1300-4N88B2	14	14	12	12
MHC1300-5N18B1	8	8	7	7
MHC1300-5O99B1	18	13	15	11
MHC1300-5O99B3	18	18	15	15
MHC1300-5R1111B1	24	13	21	11
MHC1300-5R1111B3	24	17	21	15
MHC1300-7O1111B1	22	14	20	12
MHC1300-8N1212B2	20	10	15	8
MHC1300-9O1313B1	25	12	21	10
MHC1300-9O1313B3	25	22	21	19
MHC1300-12N25B2	10	10	8	8
MHC1300-13O1616B1	20	10	18	9
MHC1300-13O1616B3	20	10	18	16
MHC1300-16P1818B2	22	22	19	19
MHC1300-18O2424B3	23	23	20	20

Notes:¹ Code minimum per IBC chapter 18.² Design all concrete pile caps in accordance to ACI 318 Chapter 22 and IBC Chapter 18. Punching shear area is based upon dimensions (d_c and d_t) on all four sides of the steel cap edges. Per IBC Chapter 18 pile cap shall extend at least 4 inches beyond edges of plate cap. Assumes uncracked concrete per ACI Chapter 22.

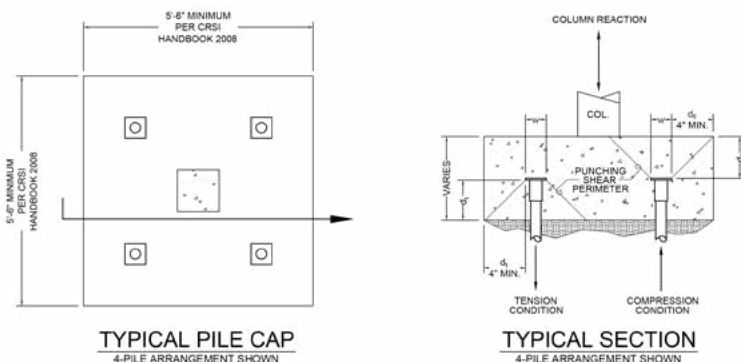

MAGNUM
PIERING
designed to support

156 Circle Freeway Dr.
Cincinnati, OH 45246
800-822-7437
www.MagnumPiering.com

MAGNUM[®] Bearing Plate Cap

Application Guide for Pile Cap Punching Shear Reinforced Concrete

Minimum Concrete Cover to Obtain Rated Capacities for Bearing Plate Caps²

Bearing Plate Cap	2500 psi Concrete		4000 psi Concrete	
	d_c (in)	d_t (in)	d_c (in)	d_t (in)
MHC1000-3B	9	7	8	6
MHC1000-3BR2	9	9	8	8
MSC1300-150M55B	7	7	6	6
MSC1300-175O6565B	9	7	8	6
MHC1300-2K55B1	6	6	5	5
MHC1300-2M55B2	6	6	5	5
MHC1300-3K55B	7	5	6	4
MHC1300-3M66BR1	9	7	8	6
MHC1300-3M6565BR2	9	9	7	7
MHC1300-35L66B1	6	5	5	5
MHC1300-35M66B1	6	5	5	5
MHC1300-4N88B1	12	8	10	7
MHC1300-4N88B2	12	12	10	10
MHC1300-5N18B1	5	5	4	4
MHC1300-5O99B1	18	11	14	9
MHC1300-5O99B3	18	18	14	14
MHC1300-5R1111B1	30	11	23	9
MHC1300-5R1111B3	30	17	23	14
MHC1300-7O1111B1	16	10	13	8
MHC1300-8N1212B2	17	7	13	6
MHC1300-9O1313B1	29	9	23	8
MHC1300-9O1313B3	29	25	23	20
MHC1300-12N25B2	6	6	5	5
MHC1300-13O1616B1	20	8	16	6
MHC1300-13O1616B3	20	18	16	14
MHC1300-16P1818B2	14	14	12	12
MHC1300-18O2424B3	15	15	13	13

Notes:¹ Code minimum per IBC chapter 18.² Design all concrete pile caps in accordance to ACI 318 Chapter 22 and IBC Chapter 18. Punching shear area is based upon dimensions (d_c and d_t) on all four sides of the steel cap edges. Per IBC Chapter 18 pile cap shall extend at least 4 inches beyond edges of plate cap. Assumes uncracked concrete per ACI Chapter 22.

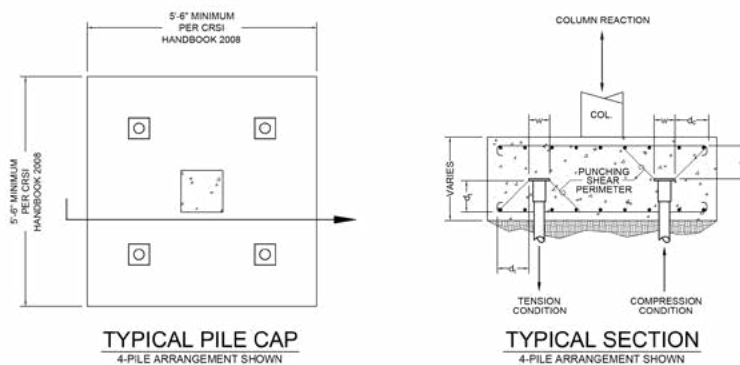

156 Circle Freeway Dr.
Cincinnati, OH 45246
800-822-7437

www.MagnumPiering.com

Foundation Brackets



Foundation Bracket Number Specification Legend

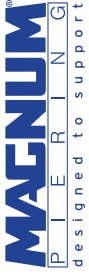

Example

The MAGNUM® Piering Foundation Bracket product number below **MP-1001-3G** is for a plate bracket with 3.13" inside diameter collar tube, and the surface preparation is Galvanized.

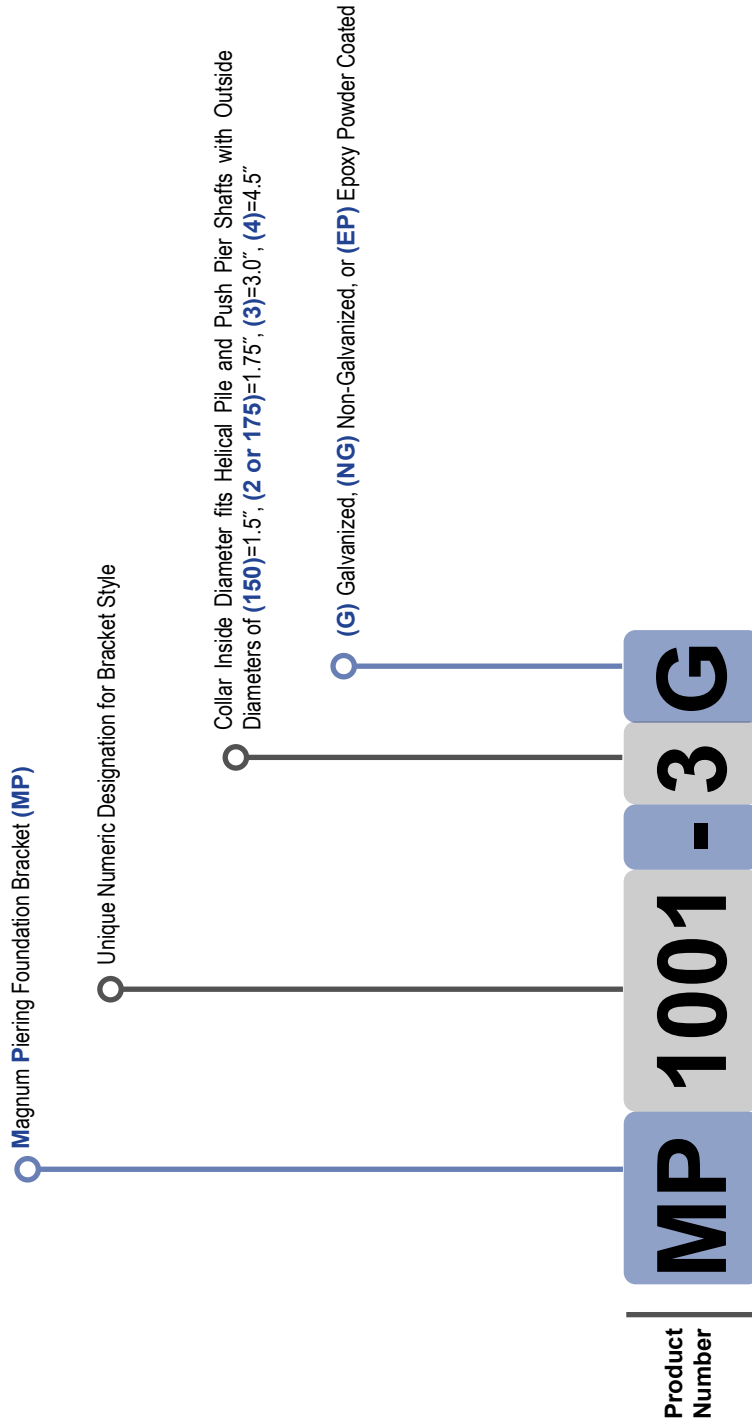

Bracket Specifications

System Ratings & Specifications

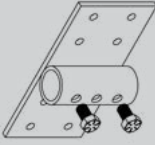
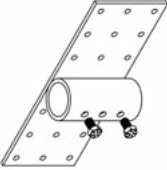
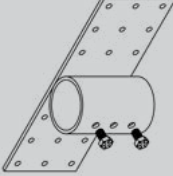
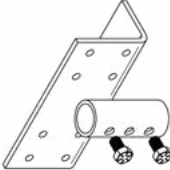
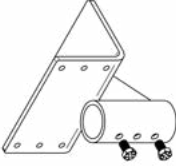
Brackets	Name	Fits Pile Dia. (in)	No. Bolts / Thru Holes	Bolt hole Dia. (in)	Structural Capacity*		Description	Surface Coating**	Schematic
					Ultimate (tons) Comp / Tens	Allowable (tons) Comp / Tens			
MP1001-2	Plate Bracket	1.75	3	3/4	7 / 7	3.5 / 3.5	6" x 12" x 3/8" Plate with 8 bolt holes	G, P	
MP1001-3	Plate Bracket	3	3	3/4	50 / 50	25 / 25	8" x 21" x 3/8" Plate with 18 bolt holes	G, P	
MP1001-4	Plate Bracket	4.5	3	3/4	50 / 50	25 / 25	8" x 22-3/8" x 3/8" Plate with 18 bolt holes	G, P	
MP1002-2	Angle Bracket	1.75	3	3/4	7 / 7	3.5 / 3.5	6" x 4" x 12" x 3/8" Angle with 8 bolt holes	G, P	
MP1002-3	Angle Bracket	3	3	3/4	50 / 16	25 / 8	8" x 8" x 24" x 1/2" Angle with 6 bolt holes	G, P	
MP1005-3	Gusseted Angle	3	3	3/4	50 / 16	25 / 8	8" x 8" x 12" x 1/2" Angle with 6 bolt holes	G, P	

Bracket Specifications

System Ratings & Specifications

Brackets	Name	Fits Pile Dia. (in)	No. Bolts / Thru Holes	Bolt hole Dia. (in)	Structural Capacity*		Description	Surface Coating**	Schematic
					Ultimate (tons) Comp / Tens	Allowable (tons) Comp / Tens			
MP1006-3	Reverse Angle	3	3	3/4	50 / 50	25 / 25	8" x 8" x 24" x 1/2" Angle with 16 bolt holes	G, P	
MP1007-3	Pivot Angle	3	3	3/4	50 / 22	25 / 11	8" x 8" x 21" x 1/2" Angle with 12 bolt holes	G, P	
MP1015-3	Light Angle	3	2	3/4	24 / 24	12 / 12	4" x 4" x 9" x 3/8" Angle with 2 bolt holes	G, P	
MP1016-3	Angle Bracket w/ Tie-Back	3	3	3/4	50 / 20	25 / 10	8" x 8" x 24" x 1/2" Angle with 18 bolt holes	G, P	
MP1017-3	Tie-Back Bracket	3	1	1-1/4	32 / 32	16 / 16	8" x 21" x 3/8" Plate with 18 bolt holes	G, P	
MP1039-3	Pin Bracket	3	3	3/4	50 / 50	25 / 25	3" x 8" x 1/2" Plate Weld Flange	P	

Bracket Specifications

System Ratings & Specifications

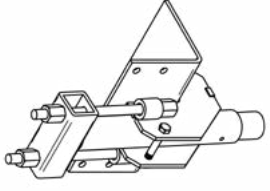
Brackets	Name	Fits Pile Dia. (in)	No. Bolts / Thru Holes	Structural Capacity*		Description	Surface Coating**	Schematic
				Ultimate (tons) Comp / Tens	Allowable (tons) Comp / Tens			
MP1008-3-6	Lifting Assembly	3	N/A	40 / 36	20 / 18	(2) #6 Gr. 75 Thread Bars with Top Fixture and Base Fixture	G, P	
MP1008-3-7	Lifting Assembly	3	N/A	50 / 36	25 / 18	(2) #7 Gr. 75 Thread Bars with Top Fixture and Base Fixture	G, P	
MP1027-3	Lifting Bracket	3	N/A	50 / 10	25 / 5	8" x 8" x 15" x 1/2" Plate with 4 bolt holes	G, P	
MP1028-3	Lifting Bracket	3	N/A	50 / 10	25 / 5	8" x 8" x 15" x 1/2" Plate with 4 bolt holes	G, P	
MP1030-150	Lifting Bracket	SQ 1.5	N/A	20 / 0	10 / 0	8" x 8" x 14" x 3/8" Plate with 4 bolt holes	G, P	
MP1030-175	Lifting Bracket	SQ 1.75	N/A	40 / 0	20 / 0	8" x 8" x 14" x 3/8" Plate with 4 bolt holes	G, P	

Bracket Specifications

System Ratings & Specifications

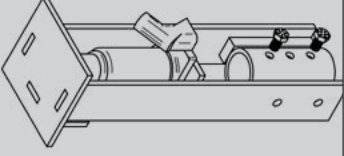
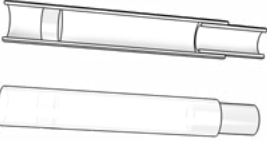
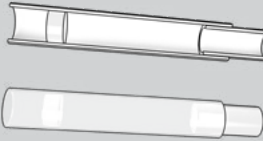
Brackets	Name	Fits Pile Dia. (in)	No. Bolts / Thru Holes	Bolt hole Dia. (in)	Structural Capacity*		Description	Surface Coating**	Schematic
					Ultimate (tons) Comp / Tens	Allowable (tons) Comp / Tens			
MP1600-3	Concentric Lift Bracket	3	3	3/4	50 / 0	25 / 0	8" x 8" x 1/2" ASTM A36 Plate	G, P	
MSA150-MP325	Adapter	SQ 1.5	N/A	N/A	35 / 0	17.5 / 0	Slip Connection with Internal Welded Block	G, P	
MSA175-MP325	Adapter	SQ 1.75	N/A	N/A	55 / 0	27.5 / 0	Slip Connection with Internal Welded Block	G, P	

Notes:

*Most MAGNUM® products are manufactured using minimum 65 ksi minimum yield strength structural tubing, or better, for the collar and ASTM A36 plate steel, or better, for the plates. As MAGNUM® is committed to testing and improving products, these specifications are subject to change. Additional product specifications available at www.magnumiering.com and in the Magnum Helical Pile Engineering Manual available upon request. Structural capacity of cap and pile system may be limited by the capacity of the pile and the structure to which the cap is connected. See MAGNUM® Helical Pile Specifications for more information. Capacity of the structure shall be determined by an engineer.

**G=Hot Dip Galvanized per ASTM A153/A123 as appropriate, P=MAGNUM® blue paint

MAGNUM® MP1001-2 Plate Bracket



Allowable Capacity 3.5 Tons

6" x 12" x 3/8" Plate with (8) 9/16" Thru Holes and 1.88" I.D. Collar Fits MP212 Steel Push Piers

Description: The MAGNUM® Plate Bracket consists of a collar tube with (3) 3/4" threaded bolt holes for connection to MAGNUM® Push Piers or Helical Piles and a steel plate with thru holes for attachment to existing concrete using expansion anchors. MAGNUM® products are manufactured in the USA according to our ISO 9001 approved quality program. MAGNUM® brackets are designed in accordance with ICC-AC308, IBC, ACI, and AISC codes. Design and detailing of the connection to the structure varies by project and is the responsibility of the registered design professional including maximum concrete span, pier spacing, concrete shear, and concrete bearing.

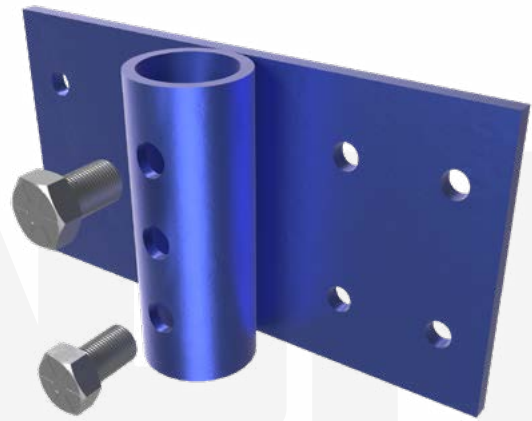
Specifications	
Collar Tube	0.37" x 1.88" I.D. ASTM A513, Fy = 65 ksi or Better
Configuration	6" x 12" x 3/8" Plate with (8) 9/16" Thru Holes for 1/2" Expansion Anchors
Pile Connection	(1, 2 or 3) 3/4" SAE J429 Grade 8 Zinc Coated to ASTM B695/F1941
Surface Coating	Galvanized per ASTM A153/A123 (G), Bare Steel (NG) or Standard MAGNUM® Blue Paint (P)
Compatibility	MP212



Connection Type	Ultimate Capacity*	Allowable Capacity*
 Single Bolted	5 Tons	2.5 Tons
 Double Bolted	7 Tons	3.5 Tons
 Triple Bolted	7 Tons	3.5 Tons

Installation Notes: Prepare the existing foundation. For steel push pier applications, attach the bracket and MAGNUM® ram. Install the push pier to the required pressure and load test. For helical pile applications, pot-hole excavate the pier location so the helix bearing plates fit below the existing foundation and the shaft is as close as possible to the face of the foundation. Install the helical pile to the correct depth and torque. Mount the bracket by sliding down the shaft rotating into position then secure to concrete. In both cases, lift the structure as needed using either a MAGNUM® ram or lifting fixture. Lock-off the pile to the bracket with one, two or three 3/4" Grade 8 bolts, or weld. To lock-off the pile, drill 11/16" diameter hole in pile shaft through threaded hole(s) in bracket collar. Install bolt(s) and use impact wrench to force bolt through pile shaft wall. (Expansion Anchors Sold Separately)

*Bracket connection to pile consists of field threaded blind bolts as described in Section 7-13 of AISC Code. Capacities shown are based on IAS accredited laboratory testing of MAGNUM® products.



U.S. Patents 5,234,287, 4,708,528, 5,123,209



MAGNUM® MP1001-3 Plate Bracket

Allowable Capacity 25 Tons



8" x 21" x 3/8" Plate with (18) 9/16" Thru Holes and 3.13" I.D. Collar

Fits MH313B, MH313BR, MH325B, MH325BR(-6) Helical Piles and MP313, MP325 Push Piers

Description: The MAGNUM® Plate Bracket consists of a collar tube with (3) 3/4" threaded bolt holes for connection to MAGNUM® Push Piers or Helical Piles and a steel plate with thru holes for attachment to existing concrete using expansion anchors. MAGNUM® products are manufactured in the USA according to our ISO 9001 approved quality program. MAGNUM® brackets are designed in accordance with ICC-AC308, IBC, ACI, and AISC codes. Design and detailing of the connection to the structure varies by project and is the responsibility of the registered design professional including maximum concrete span, pier spacing, concrete shear, and concrete bearing.

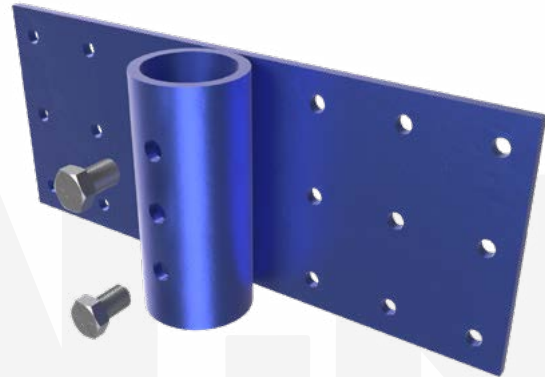
Specifications	
Collar Tube	0.37 in. x 3.13 in. I.D. ASTM A513, Fy = 65 ksi or Better
Configuration	8" x 21" x 3/8" Plate with 18 – 9/16" Thru Holes for 1/2" Expansion Anchors
Pile Connection	(1, 2, or 3) 3/4" SAE J429 Grade 8 Zinc Coated to ASTM B695/F1941
Surface Coating	Galvanized per ASTM A153/A123 (G), Bare Steel (NG) or Standard MAGNUM® Blue Paint (P)
Compatibility	MH313B, MH313BR, MH325B, MH325BR(-6), MP313, & MP325



Connection Type	Ultimate Capacity* 0.13 / 0.25 Wall Pile	Allowable Capacity* 0.13 / 0.25 Wall Pile
 Single Bolted	10 Tons / 18 Tons	5 Tons / 9 Tons
 Double Bolted	17 Tons / 35 Tons	8 Tons / 18 Tons
 Triple Bolted	28 Tons / 50 Tons	14 Tons / 25 Tons

Installation Notes: Prepare the existing foundation. For steel push pier applications, attach the bracket and MAGNUM® ram. Install the push pier to the required pressure and load test. For helical pile applications, pot-hole excavate the pier location so the helix bearing plates fit below the existing foundation and the shaft is as close as possible to the face of the foundation. Install the helical pile to the correct depth and torque. Mount the bracket by sliding down the shaft rotating into position then secure to concrete. In both cases, lift the structure as needed using either a MAGNUM® ram or lifting fixture. Lock-off the pile to the bracket with one, two or three 3/4" Grade 8 bolts, or weld. To lock-off the pile, drill 11/16" diameter hole in pile shaft through threaded hole(s) in bracket collar. Install bolt(s) and use impact wrench to force bolt through pile shaft wall. (Expansion Anchors Sold Separately)

*Bracket connection to pile consists of field threaded blind bolts as described in Section 7-13 of AISC Code. Capacities shown are based on IAS accredited laboratory testing of MAGNUM® products.



U.S. Patents 5,234,287, 4,708,528, 5,123,209

MAGNUM®
P I E R I N G
designed to support

156 Circle Freeway Dr.
Cincinnati, OH 45246
800-822-7437
www.MagnumPiering.com

MAGNUM® MP1001-4 Plate Bracket

Allowable Capacity 25 Tons



8" x 22-3/8" x 3/8" Plate with (18) 9/16" Thru Holes and 4.63" I.D. Collar

Fits MH429(-6), MH434(-6) Helical Piles and MP413, MP419, MP425, MP431 Push Piers

Description: The MAGNUM® Plate Bracket consists of a collar tube with (3) 3/4" threaded bolt holes for connection to MAGNUM® Push Piers or Helical Piles and a steel plate with thru holes for attachment to existing concrete using expansion anchors. MAGNUM® products are manufactured in the USA according to our ISO 9001 approved quality program. MAGNUM® brackets are designed in accordance with ICC-AC308, IBC, ACI, and AISC codes. Design and detailing of the connection to the structure varies by project and is the responsibility of the registered design professional including maximum concrete span, pier spacing, concrete shear, and concrete bearing.

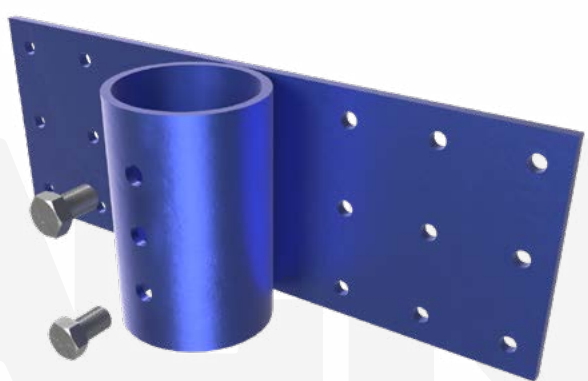
Specifications	
Collar Tube	0.37 in. x 4.63 in. I.D. ASTM A513, Fy = 65 ksi or Better
Configuration	8" x 22-3/8" x 3/8" Plate with 18 - 9/16" Thru Holes for 1/2" Expansion Anchors
Pile Connection	(1, 2, or 3) 3/4" SAE J429 Grade 8 Zinc Coated to ASTM B695/F1941
Surface Coating	Galvanized per ASTM A153/A123 (G), Bare Steel (NG) or Standard MAGNUM® Blue Paint (P)
Compatibility	MH429(-6), MH434(-6), MP413, MP419, MP425, & MP431



Connection Type	Ultimate Capacity* 0.13 / 0.25 Wall Pile	Allowable Capacity* 0.13 / 0.25 Wall Pile
 Single Bolted	10 Tons / 18 Tons	5 Tons / 9 Tons
 Double Bolted	17 Tons / 35 Tons	8 Tons / 18 Tons
 Triple Bolted	28 Tons / 50 Tons	14 Tons / 25 Tons

Installation Notes: Prepare the existing foundation. For steel push pier applications, attach the bracket and MAGNUM® ram. Install the push pier to the required pressure and load test. For helical pile applications, pot-hole excavate the pier location so the helix bearing plates fit below the existing foundation and the shaft is as close as possible to the face of the foundation. Install the helical pile to the correct depth and torque. Mount the bracket by sliding down the shaft rotating into position then secure to concrete. In both cases, lift the structure as needed using either a MAGNUM® ram or lifting fixture. Lock-off the pile to the bracket with one, two or three 3/4" Grade 8 bolts, or weld. To lock-off the pile, drill 11/16" diameter hole in pile shaft through threaded hole(s) in bracket collar. Install bolt(s) and use impact wrench to force bolt through pile shaft wall. (Expansion Anchors Sold Separately)

*Bracket connection to pile consists of field threaded blind bolts as described in Section 7-13 of AISC Code. Capacities shown are based on IAS accredited laboratory testing of MAGNUM® products.

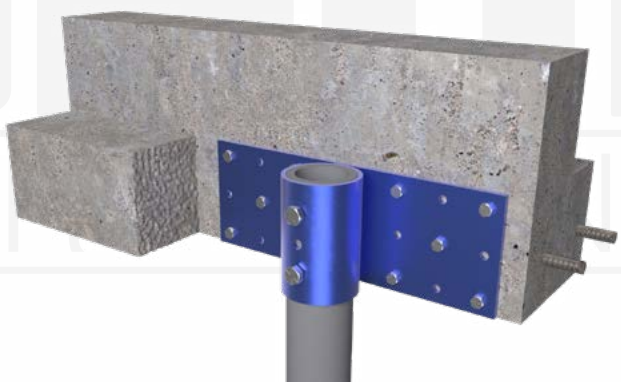

U.S. Patents 5,234,287, 4,708,528, 5,123,209



156 Circle Freeway Dr.
Cincinnati, OH 45246
800-822-7437
www.MagnumPiering.com

MAGNUM® MP1002-2 Angle Bracket



Allowable Capacity 3.5 Tons

6" x 4" x 12" x 3/8" Angle with (8) 9/16" Thru Holes and 1.83" I.D. Collar
Fits MP212 Push Piers

Description: The MAGNUM® Angle Bracket consists of a collar tube with (3) 3/4" threaded bolt holes for connection to MAGNUM® Push Piers or Helical Piles and a steel angle with thru holes for attachment to existing concrete using expansion anchors. MAGNUM® products are manufactured in the USA according to our ISO 9001 approved quality program. MAGNUM® brackets are designed in accordance with ICC-AC308, IBC, ACI, and AISC codes. Design and detailing of the connection to the structure varies by project and is the responsibility of the registered design professional including maximum concrete span, pier spacing, concrete shear, and concrete bearing.

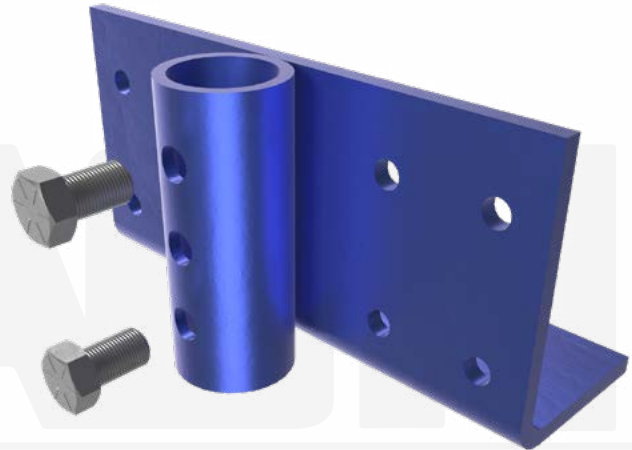
Specifications	
Collar Tube	0.37 in. x 1.83 in. I.D. ASTM A513, Fy = 65 ksi or Better
Configuration	6" x 4" x 12" x 3/8" Angle with (8) 9/16" Thru Holes for 1/2" Expansion Anchors
Pile Connection	(1 or 2) 3/4" SAE J429 Grade 8 Zinc Coated to ASTM B695/F1941
Surface Coating	Galvanized per ASTM A153/A123 (G), Bare Steel (NG) or Standard MAGNUM® Blue Paint (P)
Compatibility	MP212



Connection Type	Ultimate Capacity*	Allowable Capacity*
 Single Bolted	5 Tons	2.5 Tons
 Double Bolted	7 Tons	3.5 Tons
 Triple Bolted	7 Tons	3.5 Tons

*Bracket connection to pile consists of field threaded blind bolts as described in Section 7-13 of AISC Code. Capacities shown are based on IAS accredited laboratory testing of MAGNUM® products.

Installation Notes: Prepare the existing foundation. For steel push pier applications, apply a grout bed of high strength, fast setting, non-shrink grout at a minimum of 1/2" thick to the bottom angle face, then attach the bracket and MAGNUM® ram. Install the push pier to the required pressure and load test. For helical pile applications, excavate the pier location so the helix bearing plates fit below the existing foundation and the shaft is as close as possible to the face of the foundation. Install the helical pile to the correct depth and torque. Mount the bracket by sliding down the shaft and rotating into position. Prior to sliding bracket into position, apply a grout bed of high strength, fast setting, non-shrink grout at a minimum of 1/2" thick to the bottom angle face. In both cases, lift the structure as needed using either a MAGNUM® ram or lifting fixture. Lock-off the pile to the bracket with one, two or three 3/4" Grade 8 bolts, or weld. To lock-off the pile, drill 11/16" diameter hole in pile shaft through threaded hole(s) in bracket collar. Install bolt(s) and use impact wrench to force bolt through pile shaft wall. (Expansion Anchors Sold Separately)



U.S. Patents 5,234,287, 4,708,528, 5,123,209

MAGNUM®
P I E R I N G
designed to support

156 Circle Freeway Dr.
Cincinnati, OH 45246
800-822-7437
www.MagnumPiering.com

MAGNUM® MP1002-3 Angle Bracket

Allowable Capacity 25 Tons Compression / 8 Tons Tension



8" x 8" x 24" x 1/2" Angle with (6) 9/16" Thru Holes and 3.13" I.D. Collar

Fits MH313B, MH313BR, MH325B, MH325BR(-6) Helical Piles and MP313, MP325 Steel Push Piers

Description: The MAGNUM® Angle Bracket consists of a collar tube with (3) 3/4" threaded bolt holes for connection to MAGNUM® Push Piers or Helical Piles and a steel angle with thru holes for attachment to existing concrete using expansion anchors. MAGNUM® products are manufactured in the USA according to our ISO 9001 approved quality program. MAGNUM® brackets are designed in accordance with ICC-AC308, IBC, ACI, and AISC codes. Design and detailing of the connection to the structure varies by project and is the responsibility of the registered design professional including maximum concrete span, pier spacing, concrete shear, and concrete bearing.

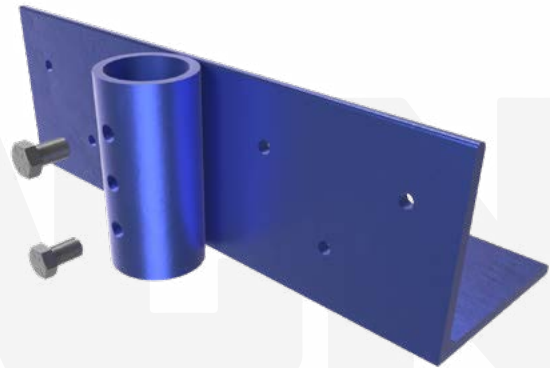
Specifications	
Collar Tube	0.37 in. x 3.13 in. I.D. ASTM A513, Fy = 65 ksi or Better
Configuration	8" x 8" x 24" x 1/2" Angle with (6) 9/16" Thru Holes for 1/2" Expansion Anchors
Pile Connection	(1, 2, or 3) 3/4" SAE J429 Grade 8 Zinc Coated to ASTM B695/F1941
Surface Coating	Galvanized per ASTM A153/A123 (G), Bare Steel (NG) or Standard MAGNUM® Blue Paint (P)
Compatibility	MH313B, MH313BR, MH325B, MH325BR(-6), MP313, & MP325



Connection Type	Ultimate Capacity* 0.13 / 0.25 Wall Pile	Allowable Capacity* 0.13 / 0.25 Wall Pile
 Single Bolted	10 Tons / 18 Tons	5 Tons / 9 Tons
 Double Bolted	17 Tons / 35 Tons	8 Tons / 18 Tons
 Triple Bolted	28 Tons / 50 Tons	14 Tons / 25 Tons

*Bracket connection to pile consists of field threaded blind bolts as described in Section 7-13 of AISC Code. Capacities shown are based on IAS accredited laboratory testing of MAGNUM® products.

Installation Notes: Prepare the existing foundation. For steel push pier applications, apply a grout bed of high strength, fast setting, non-shrink grout at a minimum of 1/2" thick to the bottom angle face, then attach the bracket and MAGNUM® ram. Install the push pier to the required pressure and load test. For helical pile applications, excavate the pier location so the helix bearing plates fit below the existing foundation and the shaft is as close as possible to the face of the foundation. Install the helical pile to the correct depth and torque. Mount the bracket by sliding down the shaft and rotating into position. Prior to sliding bracket into position, apply a grout bed of high strength, fast setting, non-shrink grout at a minimum of 1/2" thick to the bottom angle face. In both cases, lift the structure as needed using either a MAGNUM® ram or lifting fixture. Lock-off the pile to the bracket with one, two or three 3/4" Grade 8 bolts, or weld. To lock-off the pile, drill 11/16" diameter hole in pile shaft through threaded hole(s) in bracket collar. Install bolt(s) and use impact wrench to force bolt through pile shaft wall. (Expansion Anchors Sold Separately)



U.S. Patents 5,234,287, 4,708,528, 5,123,209



156 Circle Freeway Dr.
Cincinnati, OH 45246
800-822-7437
www.MagnumPiering.com

MAGNUM® MP1005-3 Gusseted Angle



Allowable Capacity 25 Tons Compression / 8 Tons Tension

8" x 8" x 12" x 1/2" Angle with (6) 9/16" Thru Holes and 3.13" I.D. Collar

Fits MH313B, MH313BR, MH325B, MH325BR(-6) Helical Piles and MP313, MP325 Steel Push Piers

Description: The MAGNUM® Angle Bracket consists of a collar tube with (3) 3/4" threaded bolt holes for connection to MAGNUM® Push Piers or Helical Piles and a steel angle with thru holes for attachment to existing concrete using expansion anchors. MAGNUM® products are manufactured in the USA according to our ISO 9001 approved quality program. MAGNUM® brackets are designed in accordance with ICC-AC308, IBC, ACI, and AISC codes. Design and detailing of the connection to the structure varies by project and is the responsibility of the registered design professional including maximum concrete span, pier spacing, concrete shear, and concrete bearing.

Specifications	
Collar Tube	0.37 in. x 3.13 in. I.D. ASTM A513, Fy = 65 ksi or Better
Configuration	8" x 8" x 12" x 1/2" Angle with (6) 9/16" Thru Holes for 1/2" Expansion Anchors
Pile Connection	(1, 2, or 3) 3/4" SAE J429 Grade 8 Zinc Coated to ASTM B695/F1941
Surface Coating	Galvanized per ASTM A153/A123 (G), Bare Steel (NG) or Standard MAGNUM® Blue Paint (P)
Compatibility	MH313B, MH313BR, MH325B, MH325BR(-6), MP313 & MP325

Connection Type	Ultimate Capacity* 0.13 / 0.25 Wall Pile	Allowable Capacity* 0.13 / 0.25 Wall Pile
 Single Bolted	10 Tons / 18 Tons	5 Tons / 9 Tons
 Double Bolted	17 Tons / 35 Tons	8 Tons / 18 Tons
 Triple Bolted	28 Tons / 50 Tons	14 Tons / 25 Tons

*Bracket connection to pile consists of field threaded blind bolts as described in Section 7-13 of AISC Code. Capacities shown are based on IAS accredited laboratory testing of MAGNUM® products.



U.S. Patents 5,234,287, 4,708,528, 5,123,209

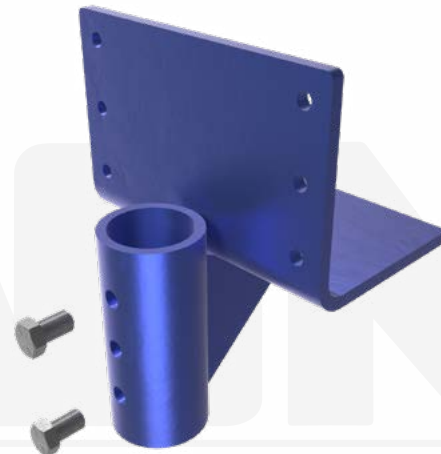

Installation Notes: Prepare the existing foundation. For steel push pier applications, apply a grout bed of high strength, fast setting, non-shrink grout at a minimum of 1/2" thick to the bottom angle face, then attach the bracket and MAGNUM® ram. Install the push pier to the required pressure and load test. For helical pile applications, excavate the pier location so the helix bearing plates fit below the existing foundation and the shaft is as close as possible to the face of the foundation. Install the helical pile to the correct depth and torque. Mount the bracket by sliding down the shaft and rotating into position. Prior to sliding bracket into position, apply a grout bed of high strength, fast setting, non-shrink grout at a minimum of 1/2" thick to the bottom angle face. In both cases, lift the structure as needed using either a MAGNUM® ram or lifting fixture. Lock-off the pile to the bracket with one, two or three 3/4" Grade 8 bolts, or weld. To lock-off the pile, drill 11/16" diameter hole in pile shaft through threaded hole(s) in bracket collar. Install bolt(s) and use impact wrench to force bolt through pile shaft wall. (Expansion Anchors Sold Separately)

MAGNUM®
P I E R I N G
designed to support

156 Circle Freeway Dr.
Cincinnati, OH 45246
800-822-7437
www.MagnumPiering.com

MAGNUM® MP1006-3 Reverse Angle

Allowable Capacity 25 Tons



8" x 8" x 24" x 1/2" Angle with (16) 9/16" Thru Holes and 3.13" I.D. Collar

Fits MP313 and MP325 Steel Push Piers

Description: The MAGNUM® Reverse Angle Bracket consists of a collar tube with (3) 3/4" threaded bolt holes for connection to MAGNUM® Push Piers or Helical Piles and a steel angle with thru holes for attachment to existing concrete using expansion anchors. MAGNUM® products are manufactured in the USA according to our ISO 9001 approved quality program. MAGNUM® brackets are designed in accordance with ICC-AC308, IBC, ACI, and AISC codes. Design and detailing of the connection to the structure varies by project and is the responsibility of the registered design professional including maximum concrete span, pier spacing, concrete shear and bearing and concrete anchor design.

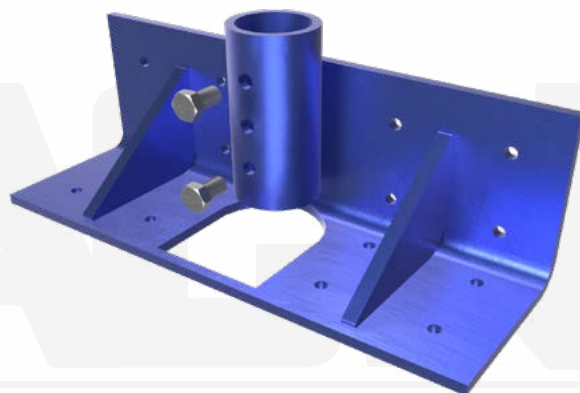
Specifications	
Collar Tube	0.37 in. x 3.13 in. I.D. ASTM A513, Fy = 65 ksi or Better
Configuration	8" x 8" x 24" x 1/2" Angle with (16) 9/16" Thru Holes for 1/2" Expansion Anchors
Pile Connection	(1, 2, or 3) 3/4" SAE J429 Grade 8 Zinc Coated to ASTM B695/F1941
Surface Coating	Galvanized per ASTM A153/A123 (G), Bare Steel (NG) or Standard MAGNUM® Blue Paint (P)
Compatibility	MP313 & MP325



Connection Type	Ultimate Capacity* 0.13 / 0.25 Wall Pile	Allowable Capacity* 0.13 / 0.25 Wall Pile
 Single Bolted	10 Tons / 18 Tons	5 Tons / 9 Tons
 Double Bolted	17 Tons / 35 Tons	8 Tons / 18 Tons
 Triple Bolted	28 Tons / 50 Tons	14 Tons / 25 Tons

Installation Notes: Prepare the existing foundation. Core a 3.50" to 5" diameter hole through the footing or slab where the push pier is located. Attach the bracket and MAGNUM® ram. Install the push pier through the core hole to the required pressure and load test. Lift the structure as needed using either a MAGNUM® ram or lifting fixture. Lock-off the pile to the bracket with one, two or three 3/4" Grade 8 bolts, or weld. To lock-off the pile, drill 11/16" diameter hole in pile shaft through threaded hole(s) in bracket collar. Install bolt(s) and use impact wrench to force bolt through pile shaft wall. (Expansion Anchors Sold Separately)

*Bracket connection to pile consists of field threaded blind bolts as described in Section 7-13 of AISC Code. Capacities shown are based on IAS accredited laboratory testing of MAGNUM® products.

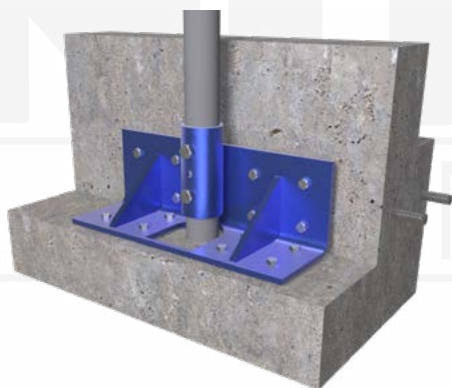

156 Circle Freeway Dr.
Cincinnati, OH 45246
800-822-7437
www.MagnumPiering.com

MAGNUM® MP1007-3 Pivot Angle

Allowable Capacity 25 Tons Compression / 11 Tons Tension



8" x 8" x 21" x 1/2" Angle with (12) 9/16" Thru Holes and 3.13" I.D. Collar

Fits MH313B, MH313BR, MH325, MH325BR Helical Piles and MP313, MP325 Steel Push Piers

Description: The MAGNUM® Pivot Angle Bracket consists of a collar tube with (3) 3/4" threaded bolt holes for connection to MAGNUM® Push Piers or Helical Piles and a steel angle with thru holes for attachment to existing concrete using expansion anchors. MAGNUM® products are manufactured in the USA according to our ISO 9001 approved quality program. MAGNUM® brackets are designed in accordance with ICC-AC358, IBC, ACI, and AISC codes. Design and detailing of the connection to the structure varies by project and is the responsibility of the registered design professional including maximum concrete span, pier spacing, concrete shear, and concrete bearing.

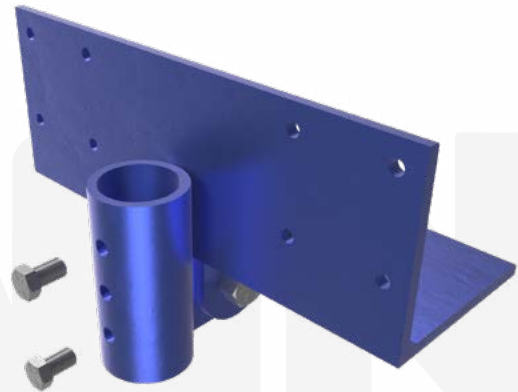
Specifications	
Collar Tube	0.37 in. x 3.13 in. I.D. ASTM A513, Fy = 65 ksi or Better
Configuration	8" x 8" x 21" x 1/2" Angle with (12) 9/16" Thru Holes for 1/2" Expansion Anchors
Pile Connection	(1, 2, or 3) 3/4" SAE J429 Grade 8 Zinc Coated to ASTM B695/F1941
Surface Coating	Galvanized per ASTM A153/A123 (G) or Standard MAGNUM® Blue Paint (P)
Compatibility	MH313B, MH313BR, MH325B, MH325BR(-6), MP313 & MP325



Connection Type	Ultimate Capacity*	Allowable Capacity*
	0.13 / 0.25 Wall Pile	0.13 / 0.25 Wall Pile
 Single Bolted	10 Tons / 18 Tons	5 Tons / 9 Tons
 Double Bolted	17 Tons / 35 Tons	8 Tons / 18 Tons
 Triple Bolted	28 Tons / 50 Tons	14 Tons / 25 Tons

Installation Notes: Prepare the existing foundation. For steel push pier applications, apply a grout bed of high strength, fast setting, non-shrink grout at a minimum of 1/2" thick to the bottom angle face, then attach the bracket and MAGNUM® ram. Install the push pier to the required pressure and load test. For helical pile applications, excavate the pier location so the helix bearing plates fit below the existing foundation and the shaft is as close as possible to the face of the foundation. Install the helical pile to the correct depth and torque. Mount the bracket by sliding down the shaft and rotating into position. Prior to sliding bracket into position, apply a grout bed of high strength, fast setting, non-shrink grout at a minimum of 1/2" thick to the bottom angle face. In both cases, lift the structure as needed using either a MAGNUM® ram or lifting fixture. Lock-off the pile to the bracket with one, two or three 3/4" Grade 8 bolts, or weld. To lock-off the pile, drill 11/16" diameter hole in pile shaft through threaded hole(s) in bracket collar. Install bolt(s) and use impact wrench to force bolt through pile shaft wall. (Expansion Anchors Sold Separately)

*Bracket connection to pile consists of field threaded blind bolts as described in Section 7-13 of AISC Code. Capacities shown are based on IAS accredited laboratory testing of MAGNUM® products.



U.S. Patents 5,234,287, 4,708,528, 5,123,209

MAGNUM
PIERING
designed to support

156 Circle Freeway Dr.
Cincinnati, OH 45246
800-822-7437
www.MagnumPiering.com

MAGNUM® MP1015-3 Light Angle

Allowable Capacity 12 Tons



4" x 4" x 9" x 3/8" Angle with (2) 9/16" Thru Holes and 3.13" I.D. Collar

Fits MH313B, MH313BR, MH325, MH325BR Helical Piles and MP313, MP325 Steel Push Piers

Description: The MAGNUM® Light Angle Bracket consists of a collar tube with (2) 3/4" threaded bolt holes for connection to MAGNUM® Push Piers or Helical Piles and a steel angle with thru holes for attachment to existing concrete using expansion anchors. MAGNUM® products are manufactured in the USA according to our ISO 9001 approved quality program. MAGNUM® brackets are designed in accordance with ICC-AC308, IBC, ACI, and AISC codes. Design and detailing of the connection to the structure varies by project and is the responsibility of the registered design professional including maximum concrete span, pier spacing, concrete shear, and concrete bearing.

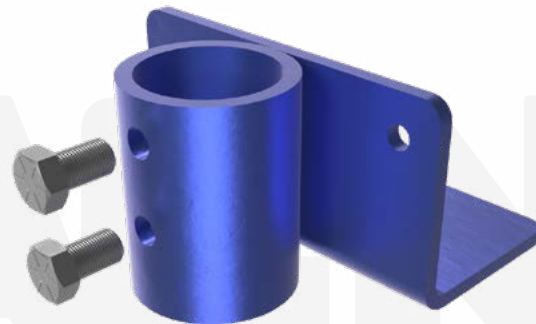
Specifications	
Collar Tube	0.37 in. x 3.13 in. I.D. ASTM A513, Fy = 65 ksi or Better
Configuration	4" x 4" x 9" x 3/8" Angle with (2) 9/16" Thru Holes for 1/2" Expansion Anchors
Pile Connection	(1 or 2) 3/4" SAE J429 Grade 8 Zinc Coated to ASTM B695/F1941
Surface Coating	Galvanized per ASTM A153/A123 (G), Bare Steel (NG) or Standard MAGNUM® Blue Paint (P)
Compatibility	MH313B, MH313BR, MH325B, MH325BR(-6), MP313 & MP325



Connection Type	Ultimate Capacity*	Allowable Capacity*
	0.13 / 0.25 Wall Pile	0.13 / 0.25 Wall Pile
 Single Bolted	10 Tons / 18 Tons	5 Tons / 9 Tons
 Double Bolted	17 Tons / 24 Tons	8 Tons / 12 Tons

*Bracket connection to pile consists of field threaded blind bolts as described in Section 7-13 of AISC Code. Capacities shown are based on IAS accredited laboratory testing of MAGNUM® products.

Installation Notes: Prepare the existing foundation. For steel push pier applications, apply a grout bed of high strength, fast setting, non-shrink grout at a minimum of 1/2" thick to the bottom angle face, then attach the bracket and MAGNUM® ram. Install the push pier to the required pressure and load test. For helical pile applications, excavate the pier location so the helix bearing plates fit below the existing foundation and the shaft is as close as possible to the face of the foundation. Install the helical pile to the correct depth and torque. Mount the bracket by sliding down the shaft and rotating into position. Prior to sliding bracket into position, apply a grout bed of high strength, fast setting, non-shrink grout at a minimum of 1/2" thick to the bottom angle face. In both cases, lift the structure as needed using either a MAGNUM® ram or lifting fixture. Lock-off the pile to the bracket with one or two 3/4" Grade 8 bolts, or weld. To lock-off the pile, drill 11/16" diameter hole in pile shaft through threaded hole(s) in bracket collar. Install bolt(s) and use impact wrench to force bolt through pile shaft wall. (Expansion Anchors Sold Separately)



U.S. Patents 5,234,287, 4,708,528, 5,123,209



156 Circle Freeway Dr.
Cincinnati, OH 45246
800-822-7437
www.MagnumPiering.com

MAGNUM® MP1016-3 Angle Bracket w/ Tie-Back

Pile Allowable Capacity 25 Tons Compression & Tension, Tie-Back Allowable Capacity 12.5 Tons Compression & Tension



8" x 8" x 24" x 1/2" Angle with (18) 9/16" Thru Holes and 3.13" I.D. Collar

Fits MH313B, MH313BR, MH325B, MH325BR Helical Piles and MP313, MP325 Steel Push Piers

Description: The MAGNUM® Angle Bracket w/ Tie-Back consists of two collar tubes with (3) 3/4" threaded bolt holes for connection to MAGNUM® Push Piers or Helical Piles and a steel angle with thru holes for attachment to existing concrete using expansion anchors. MAGNUM® products are manufactured in the USA according to our ISO 9001 approved quality program. MAGNUM® brackets are designed in accordance with ICC-AC308, IBC, ACI, and AISC codes. Design and detailing of the connection to the structure varies by project and is the responsibility of the registered design professional including maximum concrete span, pier spacing, concrete shear, and concrete bearing.

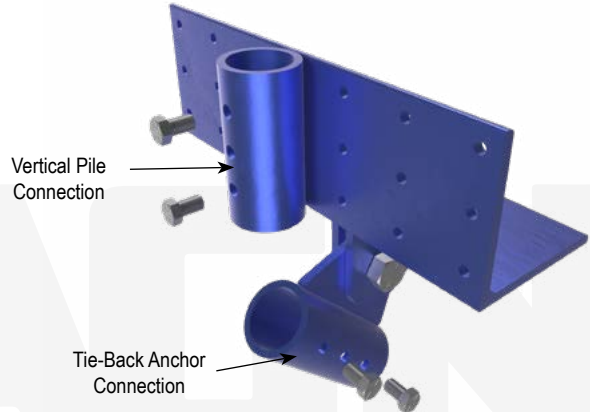
Specifications	
Collar Tube	0.37 in. x 3.13 in. I.D. ASTM A513, Fy = 65 ksi or Better
Configuration	8" x 8" x 24" x 1/2" Angle with (18) 9/16" Thru Holes for 1/2" Concrete Anchors
Pile Connection	(1, 2, or 3) 3/4" SAE J429 Grade 8 Zinc Coated to ASTM B695/F1941
Surface Coating	Galvanized per ASTM A153/A123 (G), Bare Steel (NG) or Standard MAGNUM® Blue Paint (P)
Compatibility	MH313B, MH313BR, MH325B, MH325BR(-6), MP313 & MP325



Connection Type	Vertical Pile		Tie-Back Anchor	
	Ultimate Capacity	Allowable Capacity	Ultimate Capacity	Allowable Capacity
	0.13/0.25 Wall Pile		0.13/0.25 Wall Anchor	
 Single Bolted	10 Tons / 18 Tons	5 Tons / 9 Tons	10 Tons / 18 Tons	5 Tons / 9 Tons
 Double Bolted	17 Tons / 35 Tons	8 Tons / 18 Tons	17 Tons / 21 Tons	8 Tons / 12.5 Tons
 Triple Bolted	28 Tons / 50 Tons	14 Tons / 25 Tons	21 Tons	12.5 Tons

Installation Notes: Prepare the existing foundation. For steel push pier applications, apply a grout bed of high strength, fast setting, non-shrink grout at a minimum of 1/2" thick to the bottom angle face, then attach the bracket and MAGNUM® ram. Install the push pier to the required pressure and load test. For helical pile applications, excavate the pier location so the helix bearing plates fit below the existing foundation and the shaft is as close as possible to the face of the foundation. Install the helical pile to the correct depth and torque. Mount the bracket by sliding down the shaft and rotating into position. Prior to sliding bracket into position, apply a grout bed of high strength, fast setting, non-shrink grout at a minimum of 1/2" thick to the bottom angle face. In both cases, lift the structure as needed using either a MAGNUM® ram or lifting fixture. Lock-off the pile to the bracket with one, two or three 3/4" Grade 8 bolts, or weld. To lock-off the pile, drill 11/16" diameter hole in pile shaft through threaded hole(s) in bracket collar. Install bolt(s) and use impact wrench to force bolt through pile shaft wall. (Expansion Anchors Sold Separately)



*Bracket connection to pile consists of field threaded blind bolts as described in Section 7-13 of AISC Code. Capacities shown are based on IAS accredited laboratory testing of MAGNUM® products.



156 Circle Freeway Dr.
Cincinnati, OH 45246
800-822-7437
www.MagnumPiering.com

MAGNUM® MP1017-3 Tie-Back Bracket

Allowable Capacity 10 Tons Tension

8" x 21" x 3/8" Plate with (18) 9/16" Thru Holes & Gusseted Bearing Plate

Fits MH313B, MH313BR, MH325B, MH325BR(-6), MH3521, MH3530 Helical Anchors

Description: The MAGNUM® Tie-Back bracket consists of a plate and two gussets for connection to MAGNUM® helical piles and thru holes for attachment to existing concrete using expansion anchors. MAGNUM® products are manufactured in the USA according to our ISO 9001 approved quality program. The bracket is designed in accordance with ICC-AC308, IBC, ACI, and AISC codes. Design and detailing of the connection to the structure varies by project and is the responsibility of the registered design professional including maximum concrete span, anchor spacing, concrete shear, and concrete bearing.

Specifications	
Bearing Plate	ASTM A36 w/ 1-1/2" Slotted Hole
Configuration	8" x 21" x 3/8" Plate with (18) 9/16" Thru Holes for 1/2" Expansion Anchors
Pile Connection	MHC1080-3B, MHC1080-3BR or MHC1080-35B Anchor Caps (not shown)
Surface Coating	Galvanized per ASTM A153/A123 (G), Bare Steel (NG) or Standard MAGNUM® Blue Paint (P)
Compatibility	MH313B, MH313BR, MH325B, MH325BR(-6), MH3521 & MH3530

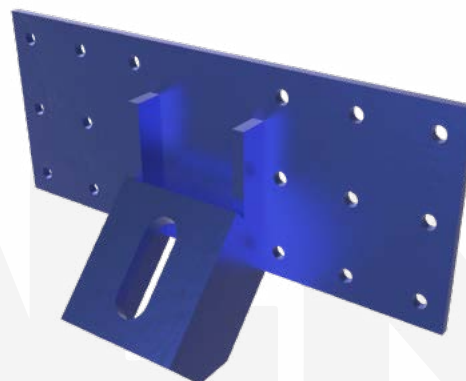

Bracket Capacity In Tension	
Ultimate	32 Tons
Allowable	16 Tons

Installation Notes: Prepare the existing foundation. Install the helical anchor to the correct depth and torque. Install a MAGNUM® MHC1080 pile cap on the anchor. Mount the bracket by sliding down over the thread bar into position. Secure to the anchor and post-tension as required for the project. Use spherical or wedge washer if anchor is not sufficiently perpendicular to bearing plate. (Expansion Anchors Sold Separately)



156 Circle Freeway Dr.
Cincinnati, OH 45246
800-822-7437
www.MagnumPiering.com

MAGNUM® MP1039-3 Pin Bracket

Allowable Capacity 25 Tons



3" x 8" x 1/2" Plate and 3.13" I.D. Collar

Fits MH313B, MH313BR, MH325, MH325BR Helical Piles and MP313, MP325 Steel Push Piers

Description: The MAGNUM® Pin bracket consists of a collar tube with (3) 3/4" threaded bolt holes for connection to MAGNUM® helical piles and push piers and steel plate for welded attachment to existing steel. MAGNUM® products are manufactured in the USA according to our ISO 9001 approved quality program. MAGNUM® brackets are designed in accordance with ICC-AC308, IBC, ACI, and AISC codes. Design and detailing of the connection to the structure varies by project and is the responsibility of the registered design professional including weld to existing steel, maximum concrete span, pier spacing, concrete shear, and concrete bearing.

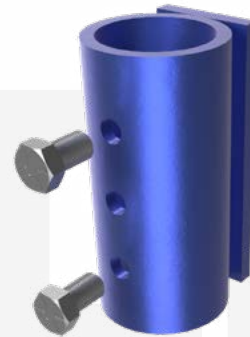
Specifications	
Collar Tube	0.37 in. x 3.13 in. I.D. ASTM A513, Fy = 65 ksi or Better
Configuration	3" x 8" x 1/2" Plate Weld Flange
Pile Connection	(1, 2, or 3) 3/4" SAE J429 Grade 8 Zinc Coated to ASTM B695/F1941
Surface Coating	Bare Steel (NG) or Standard MAGNUM® Blue Paint (P)
Compatibility	MH313B, MH313BR, MH325B, MH325BR(-6), MP313 & MP325



Connection Type	Ultimate Capacity*	Allowable Capacity*
 <p>Single Bolted</p>	10 Tons / 18 Tons	5 Tons / 9 Tons
 <p>Double Bolted</p>	17 Tons / 35 Tons	8 Tons / 18 Tons
 <p>Triple Bolted</p>	28 Tons / 50 Tons	14 Tons / 25 Tons

Installation Notes: Prepare the existing foundation. For steel push pier applications, prepare the structural steel for welding, then attach the bracket and MAGNUM® ram. Install the push pier to the required pressure and load test. For helical pile applications, pot-hole excavate the pile location so the helix bearing plates fit below the existing foundation and the shaft is as close as possible to the face of the foundation. Install the helical pile to the correct depth and torque. Prepare the structural steel for welding, then mount the bracket and install the sleeve. In both cases, lift the structure as needed using either a MAGNUM® ram or lifting fixture. Lock-off the pile to the bracket with one, two or three 3/4" Grade 8 bolts, or weld. To lock-off the pile, drill 11/16" diameter hole in pile shaft through threaded hole(s) in bracket collar. Install bolt(s) and use impact wrench to force bolt through pile shaft wall.

*Bracket connection to pile consists of field threaded blind bolts as described in Section 7-13 of AISC Code. Capacities shown are based on IAS accredited laboratory testing of MAGNUM® products.



U.S. Patents 5,234,287, 4,708,528, 5,123,209

MAGNUM®
P I E R I N G
designed to support

156 Circle Freeway Dr.
Cincinnati, OH 45246
800-822-7437
www.MagnumPiering.com

MAGNUM® MP1008-3-6 Lifting Assembly

Allowable Capacity 20 Tons Compression / 18 Tons Tension

(2) #6 Gr. 75 Thread Bars with Top Fixture and Base Fixture

Fits MP1001-3, MP1002-3, MP1005-3, MP1006-3, MP1007-3, MP1017-3 Brackets

Description: The MAGNUM® Lifting Assembly consists of a lifting shoe and two square steel beams with holes for a pair of threaded rod attachments. MAGNUM® products are manufactured in the USA according to our ISO 9001 approved quality program. MAGNUM® brackets are designed in accordance with ICC-AC358, IBC, ACI, and AISC codes. Design and detailing of the connection to the structure varies by project and is the responsibility of the registered design professional including maximum concrete span, pier spacing, concrete shear, and concrete bearing.

Specifications	
Top Fixture	3.5" x 3.5" Tube Steel
Configuration	(2) #6 Gr. 75 Thread Bars with Top Fixture and Base Fixture
Pile Connection	Compression: Direct Bearing w/ (1) 3/4" SAE J429 Grade 8 Zinc Coated to ASTM B695/F1941 into bracket collar Tension: (2) additional 3/4" through bracket collar
Surface Coating	Galvanized per ASTM A153/A123 (G), Bare Steel (NG) or Standard MAGNUM® Blue Paint (P)
Compatibility	MP1001-3, MP1002-3, MP1005-3, MP1006-3, MP1007-3 & MP1016-3

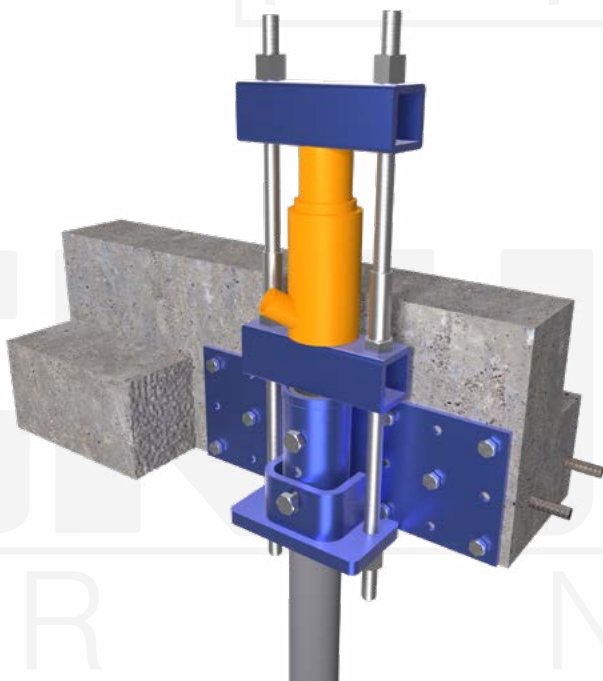

Installation Notes: After installation of pier and bracket, attach lifting assembly (MP1008A-3) to the bracket underside using the bolt provided. Snug tighten nuts on top fixture. Attach second top fixture (MP1008B-3). Place a hydraulic power pack or bottle jack between the top fixtures and lift as required. Re-tighten nuts to secure pile and bracket position. Remove upper fixture (MP1008B-3) and re-use on other piles.



156 Circle Freeway Dr.
Cincinnati, OH 45246
800-822-7437
www.MagnumPiering.com

MAGNUM[®] MP1008-3-7 Lifting Assembly

Allowable Capacity 25 Tons Compression / 18 Tons Tension

(2) #7 Gr. 75 Thread Bars with Top Fixture and Base Fixture

Fits MP1001-3, MP1002-3, MP1005-3, MP1006-3, MP1007-3, MP1017-3 Brackets

Description: The MAGNUM[®] Lifting Assembly consists of a lifting shoe and two square steel beams with holes for a pair of threaded rod attachments. MAGNUM[®] products are manufactured in the USA according to our ISO 9001 approved quality program. MAGNUM[®] brackets are designed in accordance with ICC-AC358, IBC, ACI, and AISC codes. Design and detailing of the connection to the structure varies by project and is the responsibility of the registered design professional including maximum concrete span, pier spacing, concrete shear, and concrete bearing.

Specifications	
Top Fixture	3.5" x 3.5" Tube Steel
Configuration	(2) #7 Gr. 75 Thread Bars with Top Fixture and Base Fixture
Pile Connection	Compression: Direct Bearing w/ (1) 3/4" SAE J429 Grade 8 Zinc Coated to ASTM B695/F1941 into bracket collar Tension: (2) additional 3/4" through bracket collar
Surface Coating	Galvanized per ASTM A153/A123 (G), Bare Steel (NG) or Standard MAGNUM [®] Blue Paint (P)
Compatibility	MP1001-3, MP1002-3, MP1005-3, MP1006-3, MP1007-3 & MP1016-3

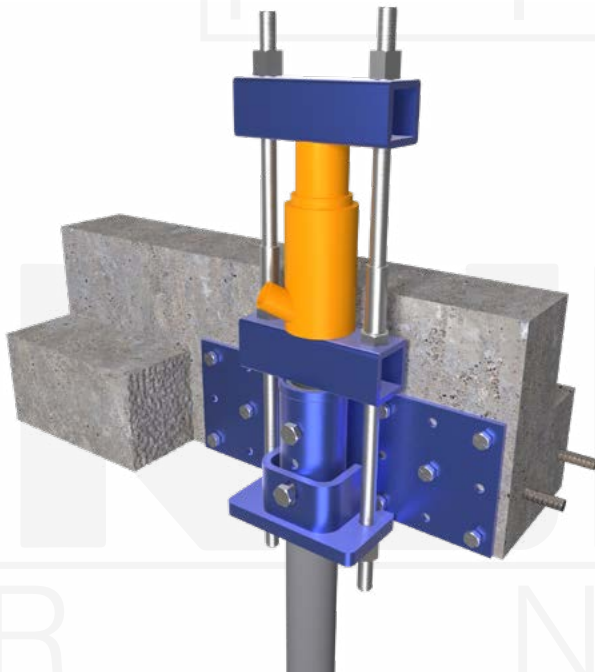
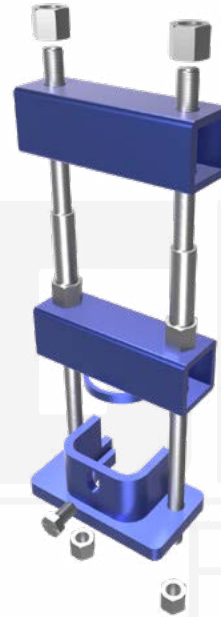

Installation Notes: After installation of pier and bracket, attach lifting assembly (MP1008A-3) to the bracket underside using the bolt provided. Snug tighten nuts on top fixture. Attach second top fixture (MP1008B-3). Place a hydraulic power pack or bottle jack between the top fixtures and lift as required. Re-tighten nuts to secure pile and bracket position. Remove upper fixture (MP1008B-3) and re-use on other piles.

MAGNUM[®]
P I E R I N G
designed to support

156 Circle Freeway Dr.
Cincinnati, OH 45246
800-822-7437
www.MagnumPiering.com



MAGNUM® MP1027-3 Lifting Bracket

Allowable Capacity 25 Tons Compression / 5 Tons Tension

8" x 8" x 15" x 1/2" Plate with (4) 9/16" Thru Holes and 3.13" I.D. Collar
 Fits MH313B, MH313BR, MH325B, MH325BR(-6) Helical Piles
 and MP313, MP322, MP325 Steel Push Piers

Description: The MAGNUM® Lifting Bracket consists of a steel angle and collar tube with (3) 3/4" threaded bolt holes for connection to MAGNUM® Push Piers or Helical Piles via a pair of threaded rods and steel T-Beam. MAGNUM® products are manufactured in the USA according to our ISO 9001 approved quality program. MAGNUM® brackets are designed in accordance with ICC-AC308, IBC, ACI, and AISC codes. Design and detailing of the connection to the structure varies by project and is the responsibility of the registered design professional including maximum concrete span, pier spacing, concrete shear, and concrete bearing.

Specifications	
Collar Tube	0.37 in. x 3.13 in. I.D. ASTM A513, Fy = 65 ksi or Better
Configuration	8" x 8" x 15" x 1/2" Plate with (4) 9/16" Thru Holes for 1/2" Expansion Anchors
Pile Connection	3" x 3" x 3/8" Cross Beam, Plus Optional 3/4" Thru Bolt (for Tension)
Surface Coating	Galvanized per ASTM A153/A123 (G), Bare Steel (NG) or Standard MAGNUM® Blue Paint (P)
Compatibility	MH313B, MH313BR, MH325B, MH325BR(-6), MP313, MP322, & MP325

Connection Type	Ultimate Capacity*	Allowable Capacity*
	0.13 / 0.25 Wall Pile	0.13 / 0.25 Wall Pile
 Single Bolted	10 Tons / 18 Tons	5 Tons / 9 Tons
 Double Bolted	17 Tons / 35 Tons	8 Tons / 18 Tons
 Triple Bolted	28 Tons / 50 Tons	14 Tons / 25 Tons

*Bracket connection to pile consists of field threaded blind bolts as described in Section 7-13 of AISC Code. Capacities shown are based on IAS accredited laboratory testing of MAGNUM® products.

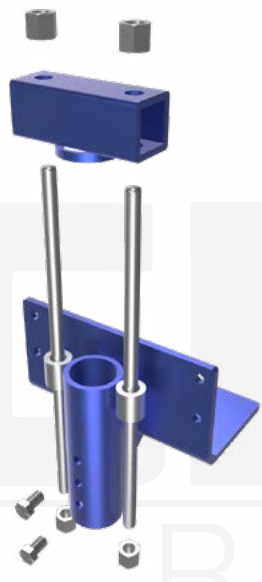

Installation Notes: Prepare the existing foundation. For steel push pier applications, apply a grout bed of high strength, fast setting, non-shrink grout at a minimum of 1/2" thick to the bottom angle face, then attach the bracket and MAGNUM® ram. Install the push pier to the required pressure and load test. For helical pile applications, pot-hole excavate the pile location so the helix bearing plates fit below the existing foundation and the shaft is as close as possible to the face of the foundation. Install the helical pile vertically to the correct depth and torque. Mount the bracket by sliding down the shaft rotating into position. Prior to rotating the bracket into position, apply a grout bed of high strength, fast setting, non-shrink grout at a minimum of 1/2" thick to the bottom angle face. In both cases, lift the structure as needed using either a "wide" MAGNUM® ram or hydraulic jack with top lifting fixture. After lift, tighten hex nuts against cross beam. Release pressure and remove ram or jack. If desired, trim thread bars flush with top of nuts. For tension applications, a minimum of (1) 3/4" lock-off bolt must be installed. To lock-off the pile, drill 11/16" diameter hole in pile shaft through threaded hole(s) in bracket collar. Install bolt(s) and use impact wrench to force bolt through pile shaft wall. (Expansion Anchors Sold Separately)



156 Circle Freeway Dr.
 Cincinnati, OH 45246
 800-822-7437
www.MagnumPiering.com



MAGNUM® MP1028-3 Lifting Bracket

Allowable Capacity 25 Tons Compression / 5 Tons Tension

8" x 8" x 15" x 1/2" Plate with (4) 9/16" Thru Holes and 3.13" I.D. Collar with 5° Angle
 Fits MH313B, MH313BR, MH325B, MH325BR(-6) Helical Piles
 and MP313, MP322, MP325 Steel Push Piers

Description: The MAGNUM® Lifting Bracket consists of a steel angle and collar tube with (3) 3/4" threaded bolt holes for connection to MAGNUM® Push Piers or Helical Piles via a pair of threaded rods and steel T-Beam. MAGNUM® products are manufactured in the USA according to our ISO 9001 approved quality program. MAGNUM® brackets are designed in accordance with ICC-AC308, IBC, ACI, and AISC codes. Design and detailing of the connection to the structure varies by project and is the responsibility of the registered design professional including maximum concrete span, pier spacing, concrete shear, and concrete bearing.

Specifications	
Collar Tube	0.37 in. x 3.13 in. I.D. ASTM A513, Fy = 65 ksi or Better
Configuration	8" x 8" x 15" x 1/2" Plate with (4) 9/16" Thru Holes for 1/2" Expansion Anchors
Pile Connection	3" x 3" x 3/8" Cross Beam, Plus Optional 3/4" Thru Bolt (for Tension)
Surface Coating	Galvanized per ASTM A153/A123 (G), Bare Steel (NG) or Standard MAGNUM® Blue Paint (P)
Compatibility	MH313B, MH313BR, MH325B, MH325BR(-6), MP313, MP322, & MP325

Connection Type	Ultimate Capacity* 0.13 / 0.25 Wall Pile	Allowable Capacity* 0.13 / 0.25 Wall Pile
 Single Bolted	10 Tons / 18 Tons	5 Tons / 9 Tons
 Double Bolted	17 Tons / 35 Tons	8 Tons / 18 Tons
 Triple Bolted	28 Tons / 50 Tons	14 Tons / 25 Tons

*Bracket connection to pile consists of field threaded blind bolts as described in Section 7-13 of AISC Code. Capacities shown are based on IAS accredited laboratory testing of MAGNUM® products.

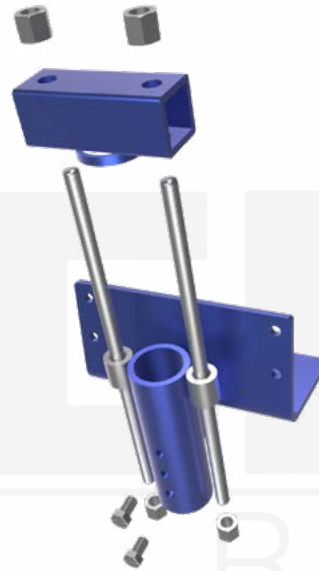
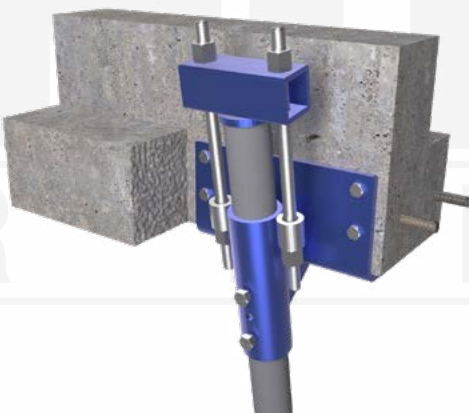

Installation Notes: Prepare the existing foundation. For steel push pier applications, apply a grout bed of high strength, fast setting, non-shrink grout at a minimum of 1/2" thick to the bottom angle face, then attach the bracket and MAGNUM® ram. Install the push pier to the required pressure and load test. For helical pile applications, pot-hole excavate the pile location so the helix bearing plates fit below the existing foundation and the shaft is as close as possible to the face of the foundation. Install the helical pile at 5° from vertical to the correct depth and torque. Mount the bracket by sliding down the shaft rotating into position. Prior to rotating the bracket into position, apply a grout bed of high strength, fast setting, non-shrink grout at a minimum of 1/2" thick to the bottom angle face. In both cases, lift the structure as needed using either a "wide" MAGNUM® ram or hydraulic jack with top lifting fixture. After lift, tighten hex nuts against cross beam. Release pressure and remove ram or jack. If desired, trim thread bars flush with top of nuts. For tension applications, a minimum of (1) 3/4" lock-off bolt must be installed. To lock-off the pile, drill 11/16" diameter hole in pile shaft through threaded hole(s) in bracket collar. Install bolt(s) and use impact wrench to force bolt through pile shaft wall. (Expansion Anchors Sold Separately)



156 Circle Freeway Dr.
 Cincinnati, OH 45246
 800-822-7437
www.MagnumPiering.com

MAGNUM® MP1030-150 Lifting Bracket

Allowable Capacity 10 Tons Compression

8" x 8" x 14" x 3/8" Plate with (4) 11/16" Thru Holes and 3" O.D. T-Beam
Fits MS150B Helical Piles

Description: The MAGNUM® Lifting Bracket consists of steel angle with a pair of gusset plates for connection to MAGNUM® Push Piers or Helical Piles via a pair of threaded rods and steel T-Beam. MAGNUM® products are manufactured in the USA according to our ISO 9001 approved quality program. MAGNUM® brackets are designed in accordance with ICC-AC308, IBC, ACI, and AISC codes. Design and detailing of the connection to the structure varies by project and is the responsibility of the registered design professional including maximum concrete span, pier spacing, concrete shear, and concrete bearing.

Specifications	
Collar Tube	0.25" x 3" O.D. x 20.25" ASTM A513, Fy = 65 ksi or Better
Configuration	8" x 8" x 14" x 3/8" Plate with (4) 11/16" Thru Holes for 5/8" Expansion Anchors
Pile Connection	3" x 3" x 3/8" Cross Beam, Plus 5/8" Cross Bolt
Surface Coating	Galvanized per ASTM A153/A123 (G), Bare Steel (NG) or Standard MAGNUM® Blue Paint (P)
Compatibility	MS150B

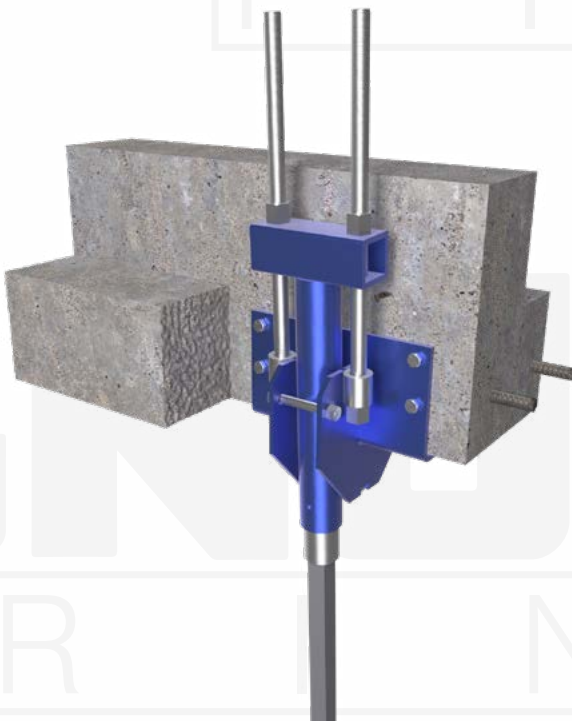
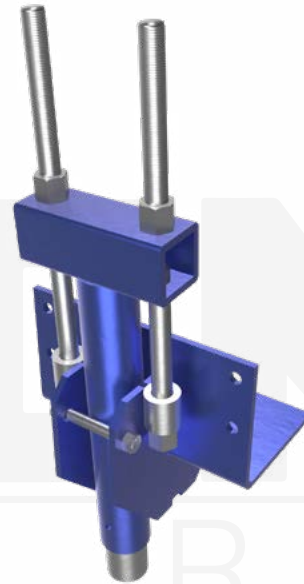

Installation Notes: Prepare the existing foundation by chipping the footing (if applicable) flush with the foundation wall. Apply a grout bed of high-strength, fast-setting, non-shrink grout a minimum of 1/2" thick to the bottom angle face. Place the bracket on the foundation and attach with four expansion anchors. Excavate under the bracket at the pile location so the helix bearing plates fit below the existing foundation and the shaft is as close as possible to the face of the bracket. Install the helical pile at 3° from vertical to the correct depth and torque. Cut-off the helical pile shaft at 1" to 6" above the bracket gusset plates (as required for lifting). Connect the helical pile to the bracket by sliding the T-Beam down the shaft; force the T-Beam toward the bracket face and lock into position with the hex bolt and nut provided. To lock-off the pile, simply tighten the (2) hex nuts located above the T-Beam. Otherwise, use MAGNUM® MP1031 Lifting Accessory to pre-load the pile to specific pressure and/or to lift the foundation. (Expansion Anchors Sold Separately)



156 Circle Freeway Dr.
Cincinnati, OH 45246
800-822-7437

www.MagnumPiering.com

MAGNUM® MP1030-175 Lifting Bracket

Allowable Capacity 20 Tons Compression

8" x 8" x 14" x 3/8" Plate with (4) 11/16" Thru Holes & 3" O.D. T-Beam

Fits MS175 Helical Piles

Description: The MAGNUM® Lifting Bracket consists of steel angle with a pair of gusset plates for connection to MAGNUM® Push Piers or Helical Piles via a pair of threaded rods and steel T-Beam. MAGNUM® products are manufactured in the USA according to our ISO 9001 approved quality program. MAGNUM® brackets are designed in accordance with ICC-AC308, IBC, ACI, and AISC codes. Design and detailing of the connection to the structure varies by project and is the responsibility of the registered design professional including maximum concrete span, pier spacing, concrete shear, and concrete bearing.

Specifications	
Collar Tube	0.313" x 3" O.D. x 24" ASTM A513, Fy = 65 ksi or Better
Configuration	8" x 8" x 14" x 3/8" Plate with (4) 11/16" Thru Holes for 5/8" Expansion Anchors
Pile Connection	3" x 3" x 3/8" Cross Beam, Plus 7/8" Cross Bolt
Surface Coating	Galvanized per ASTM A153/A123 (G), Bare Steel (NG) or Standard MAGNUM® Blue Paint (P)
Compatibility	MS175B

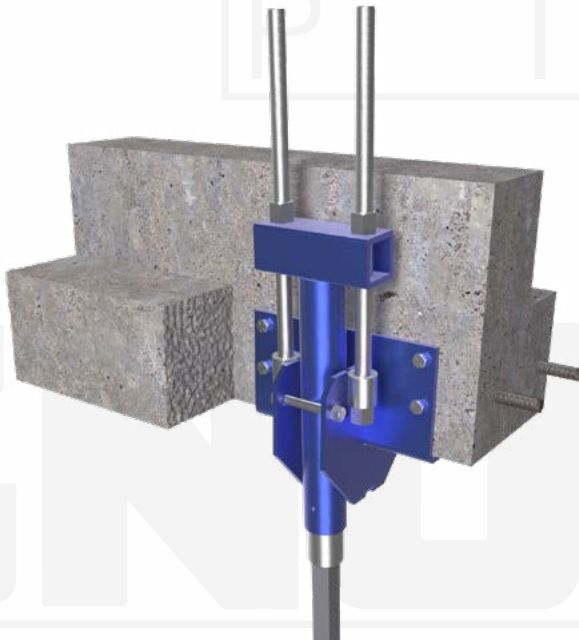
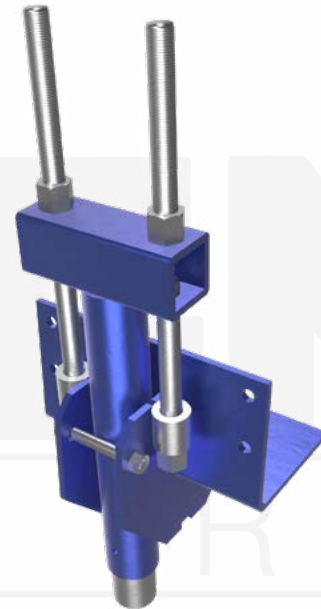

Installation Notes: Prepare the existing foundation by chipping the footing (if applicable) flush with the foundation wall. Apply a grout bed of high-strength, fast-setting, non-shrink grout a minimum of 1/2" thick to the bottom angle face. Place the bracket on the foundation and attach with four expansion anchors. Excavate under the bracket at the pile location so the helix bearing plates fit below the existing foundation and the shaft is as close as possible to the face of the bracket. Install the helical pile at 3° from vertical to the correct depth and torque. Cut-off the helical pile shaft at 1" to 6" above the bracket gusset plates (as required for lifting). Connect the helical pile to the bracket by sliding the T-Beam down the shaft; force the T-Beam toward the bracket face and lock into position with the hex bolt and nut provided. To lock-off the pile, simply tighten the (2) hex nuts located above the T-Beam. Otherwise, use MAGNUM® MP1031 Lifting Accessory to pre-load the pile to specific pressure and/or to lift the foundation. (Expansion Anchors Sold Separately)

MAGNUM®
PIERING
designed to support

156 Circle Freeway Dr.
Cincinnati, OH 45246
800-822-7437
www.MagnumPiering.com

MAGNUM® MP1600-3 Concentric Lift Bracket



Allowable Capacity 25 Tons Compression

8" x 8" x 1/2" Bearing Plate with Jack Housing Assembly and 3.13-Inch I.D. Collar
Fits MP313 and MP325 Steel Push Piers

Description: The MAGNUM® Concentric Lift Bracket is designed for use with steel push piers jacked directly below the footing or load bearing wall for all types of foundation repairs. The cap has an 8" x 8" x 1/2" bearing plate for a total of 64 sq.in of bearing area. Rather than costly and less stable multiple thread bars, the MHC1600-3 cap uses the same 3-1/8" collar lock-off technology as other MAGNUM® push piercing systems. Lock-off using one, two or three 3/4" bolts. The advantage of this system over others is in its simplicity and strength. More stable and easier to use, the MP1600-3 will provide long lasting support at an economic price. Design and detailing of the connection to the structure varies by project and is the responsibility of the registered design professional including maximum concrete span, pier spacing, concrete shear, and concrete bearing.

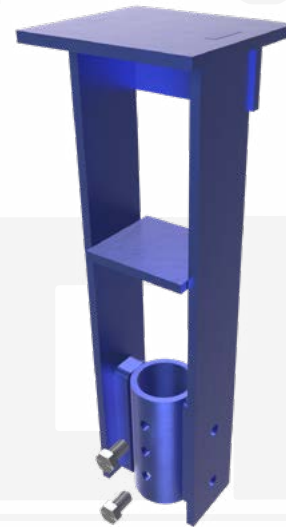
Specifications	
Collar Tube	0.25 in. x 3.13 in. I.D. ASTM A513, Fy = 65 ksi or Better
Configuration	8" x 8" x 1/2" ASTM A36 Plate
Pile Connection	(1, 2, or 3) 3/4" J429 Grade 8 Zinc Coated to ASTM B695/F1941
Surface Coating	Galvanized per ASTM A153/A123 (G), Bare Steel (NG) or MAGNUM® Blue Paint (P)
Compatibility	MP313 & MP325



Connection Type	Ultimate Capacity* 0.13 / 0.25 Wall Pile	Allowable Capacity* 0.13 / 0.25 Wall Pile
 Single Bolted	10 Tons / 18 Tons	5 Tons / 9 Tons
 Double Bolted	17 Tons / 35 Tons	8 Tons / 18 Tons
 Triple Bolted	28 Tons / 50 Tons	14 Tons / 25 Tons

*Bracket connection to pile consists of field threaded blind bolts as described in Section 7-13 of AISC Code. Capacities shown are based on IAS accredited laboratory testing of MAGNUM® products.

Installation Notes: Excavate minimum 30 inch deep narrow OSHA safe trench under foundation at designated pile location. Install steel push pier under center of footing pad or grade beam using hydraulic jack with minimum 6" stroke, two 6" shim pipes, and 18" push pier sections. Perform a pile load test upon pile completion using the installation ram. Hold pressure for a minimum 15 minutes with less than 1/32" movement. Cut-off pile at least 13.5 inches from bottom of footing/grade beam. Slide collar tube over pile. Position concentric lifting frame over pile and bolt to collar tube. Place thin layer of high strength, fast-setting, non-shrink grout over top plate. Using ram, force top plate upward against bottom of foundation and apply small setting pressure (typically 500 psi). Allow grout to set a minimum of 30 minutes. Lift and re-level structure as desired. Lock-off the pile to the bracket with one, two or three 3/4" Grade 8 bolts, or weld. To lock-off the pile, drill 11/16" diameter hole in pile shaft through threaded hole(s) in bracket collar. Install bolt(s) and use impact wrench to force bolt through pile shaft wall. Then remove jack.



156 Circle Freeway Dr.
Cincinnati, OH 45246
800-822-7437
www.MagnumPiering.com

MAGNUM® MSA150-MP325 Adapter

Allowable Capacity 17.5 Tons

3" x 1/4" Wall Adapter Collar Converts Square Shaft to Round

Fits MS150 Helical Piers and Converts to MP325 Steel Push Piers

Description: The MAGNUM® MSA150-MP325 Adapter slides over the MS150B helical pier shaft and adapts to the MP325 push pier shaft. The adapter allows MS150B helical piers to be used with MAGNUM®'s line of standard 3" collar tube brackets such as the MP1001-3, MP1002-3, MP1005-3, and MP1027-3. Use of this adapter with these brackets also enables the use of MAGNUM® push pier rams for lifting, pre-loading, and lock-off. The bracket is designed in accordance with ICC-AC358, IBC, ACI and AISC codes.

Specifications	
Collar Tube	0.25 in. x 3.00 in. O.D. ASTM A513, Fy = 65 ksi or Better
Pile Connection	Slip Connection with Internal Welded Block
Capacity	35 Tons Ultimate, 17.5 Tons Allowable (Compression Only)
Surface Coating	Galvanized per ASTM A153/A123 (G) or Standard MAGNUM® Blue Paint (P)
Compatibility	MS150B & MP325

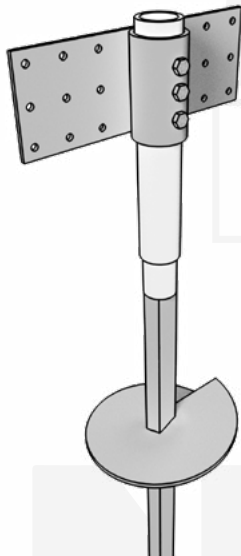

Example with MP1001

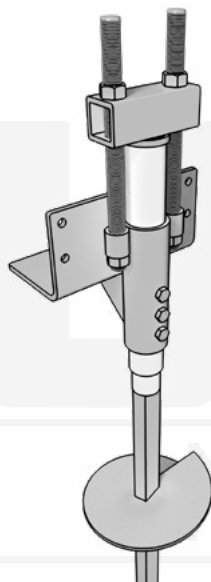

Example with MP1027

Installation Notes: Install the MS150B helical pier to the correct depth and torque. If necessary, cut-off the pier to an elevation several inches above the planned bracket location as needed for lifting. Slide the MSA150-MP325 Adapter over the MS150B shaft until it rests firmly on the internal welded block. Mount the appropriate MAGNUM® foundation bracket. If necessary add additional push pier extensions for large lifts.

MAGNUM®
PIERING
designed to support

156 Circle Freeway Dr.
Cincinnati, OH 45246
800-822-7437
www.MagnumPiering.com

MAGNUM® MSA175-MP325 Adapter

Allowable Capacity 27.5 Tons

3" x 1/4" Wall Adapter Collar Converts Square Shaft to Round
Fits MS175B Helical Piers and Converts to MP325 Steel Push Piers

Description: The MAGNUM® MSA175-MP325 Adapter slides over the MS175B helical pier shaft and adapts to the MP325 push pier shaft. The adapter allows MS175B helical piers to be used with MAGNUM®'s line of standard 3" collar tube brackets such as the MP1001-3, MP1002-3, MP1005-3, and MP1027-3. Use of this adapter with these brackets also enables the use of MAGNUM® push pier rams for lifting, pre-loading, and lock-off. The bracket is designed in accordance with ICC-AC358, IBC, ACI and AISC codes.

Specifications	
Collar Tube	0.25 in. x 3.00 in. O.D. ASTM A513, Fy = 65 ksi or Better
Pile Connection	Slip Connection with Internal Welded Block
Capacity	55 Tons Ultimate, 27.5 Tons Allowable (Compression Only)
Surface Coating	Galvanized per ASTM A153/A123 (G) or Standard MAGNUM® Blue Paint (P)
Compatibility	MS175B & MP325

Adapter

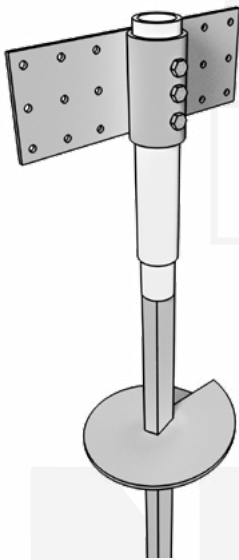
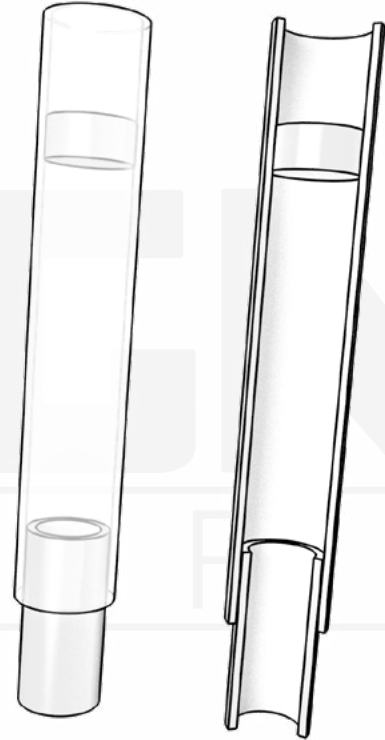

Example with MP1001

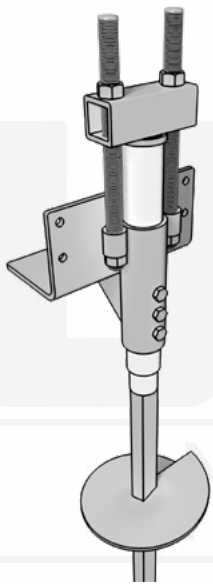

Example with MP1027

Installation Notes: Install the MS175B helical pier to the correct depth and torque. If necessary, cut-off the pier to an elevation several inches above the planned bracket location as needed for lifting. Slide the MSA175-MP325 Adapter over the MS175B shaft until it rests firmly on the internal welded block. Mount the appropriate MAGNUM® foundation bracket. If necessary add additional push pier extensions for large lifts.



156 Circle Freeway Dr.
Cincinnati, OH 45246
800-822-7437
www.MagnumPiering.com

Boardwalk & Wood Support Brackets

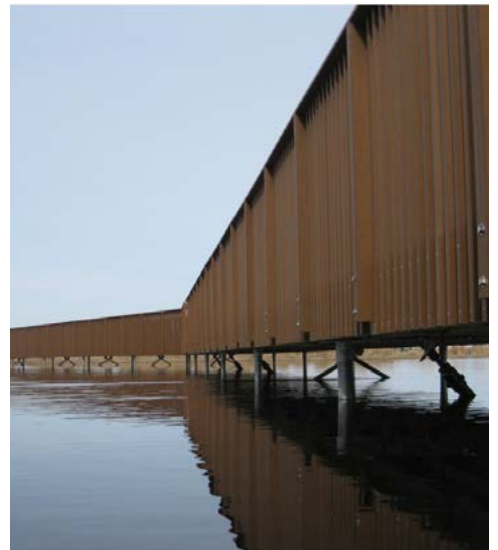

MAGNUM® MHC1120-3B Wood Beam Cap

Allowable Capacity - 8 Tons Compression / 8 Tons Tension

11" Long 3-1/2" x 3-1/2" x 1/4" Angle & 3.13-Inch I.D. Collar

Fits MH313B, MH313BR & MH325B Helical Piles

Description: MAGNUM® Wood Beam Caps consist of a collar tube with a bolt hole for connection to MAGNUM® Helical Piles and an angle for attachment to a wood beam. MAGNUM® products are manufactured in the USA according to our ISO 9001 approved quality program. Structural capacities are developed according to AISC 360 considering an average design life of 75 years for bare steel in most soil conditions. Hot-dip galvanizing is available upon request. Design and detailing of the structure, to which bearing plate cap is attached varies by project and is the responsibility of the registered design professional including crushing strength and span of wood beam.

Specifications	
Collar Tube	0.25" x 3.13" I.D. ASTM A513, Fy = 65 ksi or Better
End Effector	3-1/2" x 3-1/2" x 1/4" – 11" Long Angle with holes for (5) 1/2" Lag Bolts
Pile Connection	(1) 7/8" Dia. SAE J429 Grade 5 Zinc Coated to ASTM B695/F1941
Coating	Galvanized per ASTM A153/A123 (G), Bare Steel (NG), or Epoxy Coated per ICC-ES AC228 (EP)
Compatibility	MH313B, MH313BR, MH325B
Capacity	
Ultimate Compression/ Tension	16 Tons / 16 Tons
Allowable Compression/ Tension	8 Tons / 8 Tons



Notes: Cap capacity is developed using the ASD design method and considers strength of collar, end effector, and pile connection. Capacity may be limited by the helical pile itself, bearing/pullout capacity of soil, or strength of the structure to which the cap is attached. Strength of the structure may be limited by crushing strength, span or bolt bearing on the wood beam.

Installation Notes: After installation of a MAGNUM® Helical Pile to the correct depth, torque, and capacity, cut-off the pile shaft at the proper elevation. Drill (1) 15/16" diameter hole through the shaft using a MAGNUM® drill template. Place the pile cap over the shaft and secure with (1) 7/8" bolt. Snug tighten nut. Place wood beam on cap angle and secure with 1/2" lag bolts as required for the project.



Lag Bolts Sold Separately

MAGNUM®
PIERING
designed to support

156 Circle Freeway Dr.
Cincinnati, OH 45246
800-822-7437
www.MagnumPiering.com

MAGNUM® MHC1121-3B Wood Beam Cap

Allowable Capacity 16 Tons Compression / 16 Tons Tension

4" x 4" x 3/8" – 21" Angle & 3.13-Inch I.D. Collar
 Fits MH313B, MH313BR & MH325B Helical Piles

Description: MAGNUM® Wood Beam Caps consist of a collar tube with a bolt hole for connection to MAGNUM® Helical Piles and an angle for attachment to a wood beam. MAGNUM® products are manufactured in the USA according to our ISO 9001 approved quality program. Structural capacities are developed according to AISC 360 considering an average design life of 75 years for bare steel in most soil conditions. Hot-dip galvanizing is available upon request. Design and detailing of the structure, to which bearing plate cap is attached varies by project and is the responsibility of the registered design professional including crushing strength and span of wood beam.

Specifications	
Collar Tube	0.25" x 3.13" I.D. ASTM A513, Fy = 65 ksi or Better
End Effector	4" x 4" x 3/8" – 21" Long Angle with Holes for (10) 1/2" Lag Bolts
Pile Connection	(1) 7/8" Dia. SAE J429 Grade 5 Zinc Coated to ASTM B695/F1941
Coating	Galvanized per ASTM A153/A123 (G), Bare Steel (NG), or Epoxy Coated per ICC-ES AC228 (EP)
Compatibility	MH313B, MH313BR, MH325B
Capacity	
Ultimate Compression/ Tension	32 Tons / 32 Tons
Allowable Compression/ Tension	16 Tons / 16 Tons



Notes: Cap capacity is developed using the ASD design method and considers strength of collar, end effector, and pile connection. Capacity may be limited by the helical pile itself, bearing/pullout capacity of soil, or strength of the structure to which the cap is attached. Strength of the structure may be limited by crushing strength, span or bolt bearing on the wood beam.

Installation Notes: After installation of a MAGNUM® Helical Pile to the correct depth, torque, and capacity, cut-off the pile shaft at the proper elevation. Drill (1) 15/16" diameter hole through the shaft using a MAGNUM® drill template. Place the pile cap over the shaft and secure with (1) 7/8" bolt. Snug tighten nut. Place wood beam on cap angle and secure with 1/2" lag bolts as required for the project.



Lag Bolts Sold Separately



156 Circle Freeway Dr.
 Cincinnati, OH 45246
 800-822-7437

www.MagnumPiering.com

MAGNUM® MHC1122-3 Wood Beam Cap

Allowable Capacity 6 Tons Compression / 6 Tons Tension

8" x 4" x 1/8" – 8" Long Angle & 3.13-Inch I.D. Collar

Fits MH313B, MH313BR, MH325B & MH325BR(-6) Helical Piles

Description: MAGNUM® Wood Beam Caps consist of a collar tube with a bolt hole for connection to MAGNUM® Helical Piles and an angle for attachment to a wood beam. MAGNUM® products are manufactured in the USA according to our ISO 9001 approved quality program. Structural capacities are developed according to AISC 360 considering an average design life of 75 years for bare steel in most soil conditions. Hot-dip galvanizing is available upon request. Design and detailing of the structure, to which bearing plate cap is attached varies by project and is the responsibility of the registered design professional including crushing strength and span of wood beam.

Specifications	
Collar Tube	0.25" x 3.13" I.D. ASTM A513, Fy = 65 ksi or Better
End Effector	8" x 4" x 1/8" – 8" Long Angle with holes for (4) 1/2" Lag Bolts
Pile Connection	(4) Hilti EDS PAF Zinc Coated to ASTM B695/F1941
Coating	Galvanized per ASTM A153/A123 (G), Bare Steel (NG), or Epoxy Coated per ICC-ES AC228 (EP)
Compatibility	MH313B, MH313BR, MH325B, MH325BR(-6)
Capacity	
Ultimate Compression/ Tension	12 Tons / 12 Tons
Allowable Compression/ Tension	6 Tons / 6 Tons

Notes: Cap capacity is developed using the ASD design method and considers strength of collar, end effector, and pile connection. Capacity may be limited by the helical pile itself, bearing/pullout capacity of soil, or strength of the structure to which the cap is attached. Strength of the structure may be limited by crushing strength, span or bolt bearing on the wood beam.



Installation Notes: After installation of a MAGNUM® Helical Pile to the correct depth, torque, and capacity, cut-off the pile shaft at the proper elevation. Place the pile cap over the shaft and secure with 4 Hilti EDS PAF. Place wood beam on cap angle and secure with 1/2" lag bolts as required for the project. If required, install MAGNUM® K-brace system in accordance with installation instructions for that product.



K-Brace Assembly & Lag Bolts Sold Separately

MAGNUM®
P I E R I N G
designed to support

156 Circle Freeway Dr.
Cincinnati, OH 45246
800-822-7437
www.MagnumPiering.com

MAGNUM® MHC1123-3B Wood Beam Cap

Allowable Capacity 8 Tons Compression / 6 Tons Tension

8" x 3-3/4" x 1/8" – 6" Long Angle & 3.13-Inch I.D. Collar Fits MH313B, MH313BR & MH325B Helical Piles

Description: MAGNUM® Wood Beam Caps consist of a collar tube with a bolt hole for connection to MAGNUM® Helical Piles and an angle for attachment to a wood beam. MAGNUM® products are manufactured in the USA according to our ISO 9001 approved quality program. Structural capacities are developed according to AISC 360 considering an average design life of 75 years for bare steel in most soil conditions. Hot-dip galvanizing is available upon request. Design and detailing of the structure, to which bearing plate cap is attached varies by project and is the responsibility of the registered design professional including crushing strength and span of wood beam.

Specifications	
Collar Tube	0.25" x 3.13" I.D. ASTM A513, Fy = 65 ksi or Better
End Effector	8" x 3-3/4" x 1/8" – 6" Long Angle with Holes for (3) 1/2" Lag Bolts
Pile Connection	(1) 7/8" Dia. SAE J429 Grade 5 Zinc Coated to ASTM B695/F1941
Coating	Galvanized per ASTM A153/A123 (G), Bare Steel (NG), or Epoxy Coated per ICC-ES AC228 (EP)
Compatibility	MH313B, MH313BR, MH325B
Capacity	
Ultimate Compression/Tension	16 Tons / 12 Tons
Allowable Compression/Tension	8 Tons / 6 Tons

Notes: Cap capacity is developed using the ASD design method and considers strength of collar, end effector, and pile connection. Capacity may be limited by the helical pile itself, bearing/pullout capacity of soil, or strength of the structure to which the cap is attached. Strength of the structure may be limited by crushing strength, span or bolt bearing on the wood beam.

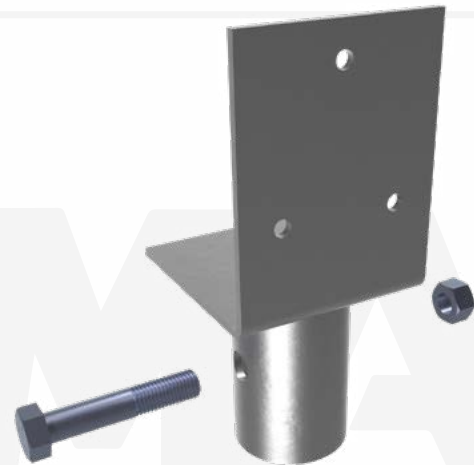

Installation Notes: After installation of a MAGNUM® Helical Pile to the correct depth, torque, and capacity, cut-off the pile shaft at the proper elevation. Drill (1) 15/16" diameter hole through the shaft using a MAGNUM® drill template. Place the pile cap over the shaft and secure with (1) 7/8" bolt. Snug tighten nut. Place wood beam on cap angle and secure with 1/2" lag bolts as required for the project.

Lag Bolts Sold Separately



156 Circle Freeway Dr.
Cincinnati, OH 45246
800-822-7437

www.MagnumPiering.com

WOOD

MAGNUM® MHC1124-3 Wood Beam Cap

Allowable Capacity 7 Tons Compression / 5 Tons Tension

8" x 4" x 1/8" – 8" Long Angle & 3.13-Inch I.D. Collar
 Fits MH313B, MH313BR & MH325B Helical Piles

Description: MAGNUM® Wood Beam Caps consist of a collar tube with a bolt hole for connection to MAGNUM® Helical Piles and an angle for attachment to a wood beam. MAGNUM® products are manufactured in the USA according to our ISO 9001 approved quality program. Structural capacities are developed according to AISC 360 considering an average design life of 75 years for bare steel in most soil conditions. Hot-dip galvanizing is available upon request. Design and detailing of the structure, to which bearing plate cap is attached varies by project and is the responsibility of the registered design professional including crushing strength and span of wood beam.

Specifications	
Collar Tube	0.25" x 3.13" I.D. ASTM A513, Fy = 65 ksi or Better
End Effector	8" x 4" x 1/8" – 8" Long Angle with holes for (4) 1/2" Lag Bolts
Pile Connection	(1) 7/8" Dia. SAE J429 Grade 5 Zinc Coated to ASTM B695/F1941
Coating	Galvanized per ASTM A153/A123 (G), Bare Steel (NG), or Epoxy Coated per ICC-ES AC228 (EP)
Compatibility	MH313B, MH313BR, MH325B
Capacity	
Ultimate Compression/ Tension	14 Tons / 10 Tons
Allowable Compression/ Tension	7 Tons / 5 Tons

Notes: Cap capacity is developed using the ASD design method and considers strength of collar, end effector, and pile connection. Capacity may be limited by the helical pile itself, bearing/pullout capacity of soil, or strength of the structure to which the cap is attached. Strength of the structure may be limited by crushing strength, span or bolt bearing on the wood beam.



Lag Bolts Sold Separately

Installation Notes: After installation of a MAGNUM® Helical Pile to the correct depth, torque, and capacity, cut-off the pile shaft at the proper elevation. Drill (1) 15/16" diameter hole through the shaft using a MAGNUM® drill template. Place the pile cap over the shaft and secure with (1) 7/8" bolt. Snug tighten nut. Place wood beam on cap angle and secure with 1/2" lag bolts as required for the project. If required, install MAGNUM® K-brace system in accordance with installation instructions for that product.

MAGNUM®
 P I E R I N G
 designed to support

156 Circle Freeway Dr.
 Cincinnati, OH 45246
 800-822-7437
www.MagnumPiering.com

MAGNUM® MHC1125-3B Wood Beam Cap

Allowable Capacity 8 Tons Compression / 8 Tons Tension

7" x 5" x 1/4" – 7" Long Angle & 3.13-Inch I.D. Collar
 Fits MH313B, MH313BR & MH325B Helical Piles

Description: MAGNUM® Wood Beam Caps consist of a collar tube with a bolt hole for connection to MAGNUM® Helical Piles and an angle for attachment to a wood beam. MAGNUM® products are manufactured in the USA according to our ISO 9001 approved quality program. Structural capacities are developed according to AISC 360 considering an average design life of 75 years for bare steel in most soil conditions. Hot-dip galvanizing is available upon request. Design and detailing of the structure, to which bearing plate cap is attached varies by project and is the responsibility of the registered design professional including crushing strength and span of wood beam.

Specifications	
Collar Tube	0.25" x 3.13" I.D. ASTM A513, Fy = 65 ksi or Better
End Effector	7" x 5" x 1/4" – 7" Long Angle with Holes for (2) 1/2" Lag Bolts
Pile Connection	(1) 7/8" Dia. SAE J429 Grade 5 Zinc Coated to ASTM B695/F1941
Coating	Galvanized per ASTM A153/A123 (G), Bare Steel (NG), or Epoxy Coated per ICC-ES AC228 (EP)
Compatibility	MH313B, MH313BR, MH325B
Capacity	
Ultimate Compression/ Tension	16 Tons / 16 Tons
Allowable Compression/ Tension	8 Tons / 8 Tons

Notes: Cap capacity is developed using the ASD design method and considers strength of collar, end effector, and pile connection. Capacity may be limited by the helical pile itself, bearing/pullout capacity of soil, or strength of the structure to which the cap is attached. Strength of the structure may be limited by crushing strength, span or bolt bearing on the wood beam.

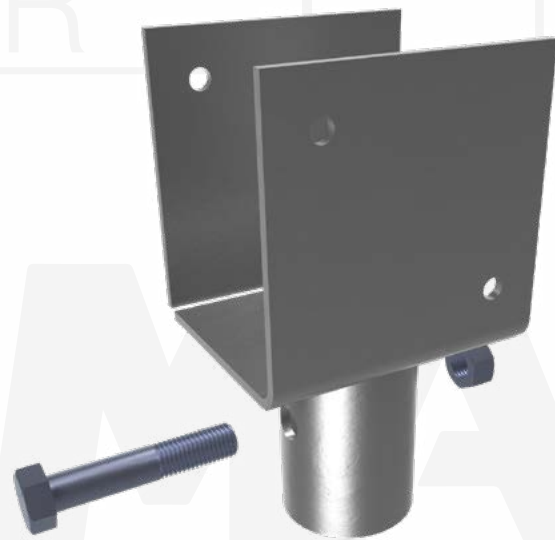

Lag Bolts Sold Separately

Installation Notes: After installation of a MAGNUM® Helical Pile to the correct depth, torque, and capacity, cut-off the pile shaft at the proper elevation. Drill (1) 15/16" diameter hole through the shaft using a MAGNUM® drill template. Place the pile cap over the shaft and secure with (1) 7/8" bolt. Snug tighten nut. Place wood beam on cap angle and secure with 1/2" lag bolts as required for the project.

WOOD



156 Circle Freeway Dr.
 Cincinnati, OH 45246
 800-822-7437
www.MagnumPiering.com

MAGNUM® MHC1127-3BR1 Wood Beam Cap

Allowable Capacity 8 Tons Compression / 8 Tons Tension

7" x 7" x 1/4" by 4-5/8" Wide Bent Plate & 3.13-Inch I.D. Collar
 Fits MH325BR(-6) Helical Piles

Description: MAGNUM® Wood Beam Caps consist of a collar tube with a bolt hole for connection to MAGNUM® Helical Piles and a 'U' shaped bent plate for attachment to a wood beam. MAGNUM® products are manufactured in the USA according to our ISO 9001 approved quality program. Structural capacities are developed according to AISC 360 considering an average design life of 75 years for bare steel in most soil conditions. Hot-dip galvanizing is available upon request. Design and detailing of the structure, to which bearing plate cap is attached varies by project and is the responsibility of the registered design professional including crushing strength and span of wood beam..

Specifications	
Collar Tube	0.25" x 3.13" I.D. ASTM A513, Fy = 65 ksi or Better
End Effector	7" x 7" x 1/4" x 4-5/8" 'U' Shaped Bent Plate with Holes for (4) 1/2" Lag Bolts
Pile Connection	(1) 1" Dia. SAE J429 Grade 8 Zinc Coated to ASTM B695/F1942
Coating	Galvanized per ASTM A153/A123 (G), Bare Steel (NG), or Epoxy Coated per ICC-ES AC228 (EP)
Compatibility	MH325BR(-6)
Capacity	
Ultimate Compression/ Tension	16 Tons / 16 Tons
Allowable Compression/ Tension	8 Tons / 8 Tons

Notes: Cap capacity is developed using the ASD design method and considers strength of collar, end effector, and pile connection. Capacity may be limited by the helical pile itself, bearing/pullout capacity of soil, or strength of the structure to which the cap is attached. Strength of the structure may be limited by crushing strength, span or bolt bearing on the wood beam.

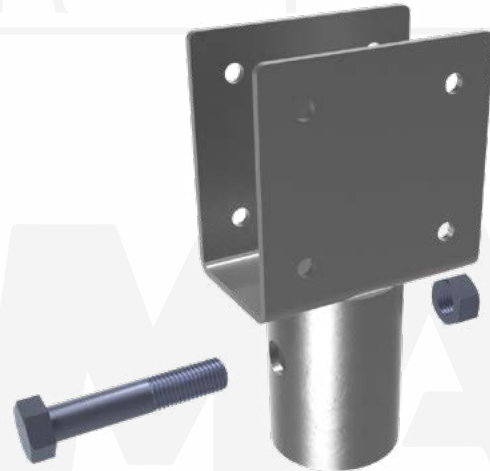

Lag Bolts Sold Separately

Installation Notes: After installation of a MAGNUM® Helical Pile to the correct depth, torque, and capacity, cut-off the pile shaft at the proper elevation. Drill (1) 1-1/16" diameter hole through the shaft using a MAGNUM® drill template. Place the pile cap over the shaft and secure with (1) 1" bolt. Snug tighten nut. Place wood beam on cap angle and secure with 1/2" lag bolts as required for the project.



156 Circle Freeway Dr.
 Cincinnati, OH 45246
 800-822-7437
www.MagnumPiering.com

MAGNUM® MHC1130-3B Wood Corner Cap

Allowable Capacity 8 Tons Compression / 8 Tons Tension

(2) Intersecting 3-1/2" x 3-1/2" x 1/4" – 7-1/4" Long Angles & 3.13-Inch I.D. Collar
Fits MH313B, MH313BR & MH325B Helical Piles

Description: MAGNUM® Wood Corner Caps consist of a collar tube with a bolt hole for connection to MAGNUM® Helical Piles and an angle for attachment to a wood beam. MAGNUM® products are manufactured in the USA according to our ISO 9001 approved quality program. Structural capacities are developed according to AISC 360 considering an average design life of 75 years for bare steel in most soil conditions. Hot-dip galvanizing is available upon request. Design and detailing of the structure, to which bearing plate cap is attached varies by project and is the responsibility of the registered design professional including crushing strength and span of wood beam.

Specifications	
Collar Tube	0.25" x 3.13" I.D. ASTM A513, Fy = 65 ksi or Better
End Effector	3-1/2" x 3-1/2" x 1/4" – 7-1/4" Long Angle at 90° with holes for (4) 1/2" Lag Bolts
Pile Connection	(1) 7/8" SAE J429 Grade 5 Zinc Coated to ASTM B695/F1941
Coating	Galvanized per ASTM A153/A123 (G), Bare Steel (NG), or Epoxy Coated per ICC-ES AC228 (EP)
Compatibility	MH313B, MH313BR, MH325B
Capacity	
Ultimate Compression/ Tension	16 Tons / 16 Tons
Allowable Compression/ Tension	8 Tons / 8 Tons

Notes: Cap capacity is developed using the ASD design method and considers strength of collar, end effector, and pile connection. Capacity may be limited by the helical pile itself, bearing/pullout capacity of soil, or strength of the structure to which the cap is attached. Strength of the structure may be limited by crushing strength, span or bolt bearing on the wood beam.



Lag Bolts Sold Separately

Installation Notes: After installation of a MAGNUM® Helical Pile to the correct depth, torque, and capacity, cut-off the pile shaft at the proper elevation. Drill (1) 15/16" hole using MAGNUM® drill template. Place the pile cap over the shaft and secure with (1) 7/8" bolt. Snug tighten nut. Place wood beams on cap angle and secure with 1/2" lag bolts as required for the project.

WOOD



156 Circle Freeway Dr.
Cincinnati, OH 45246
800-822-7437
www.MagnumPiering.com

MAGNUM® MHC1130-35B Wood Corner Cap

Allowable Capacity 8 Tons Compression / 8 Tons Tension

(2) Intersecting L3-1/2" x 3-1/2" x 1/4" – 7-1/4" Long Angles & 3.63-Inch I.D. Collar
Fits MH3521 & MH3530 Helical Piles

Description: MAGNUM® Wood Corner Caps consist of a collar tube with a bolt hole for connection to MAGNUM® Helical Piles and an angle for attachment to a wood beam. MAGNUM® products are manufactured in the USA according to our ISO 9001 approved quality program. Structural capacities are developed according to AISC 360 considering an average design life of 75 years for bare steel in most soil conditions. Hot-dip galvanizing is available upon request. Design and detailing of the structure, to which bearing plate cap is attached varies by project and is the responsibility of the registered design professional including crushing strength and span of wood beam.

Specifications	
Collar Tube	0.31" x 3.63" I.D. ASTM A513, Fy = 65 ksi or Better
End Effector	3-1/2" x 3-1/2" x 1/4" – 7-1/4" Long Angles at 90° with holes for (4) 1/2" Lag Bolts
Pile Connection	(1) 1" SAE J429 Grade 8 Zinc Coated to ASTM B695/F1941
Coating	Galvanized per ASTM A153/A123 (G), Bare Steel (NG), or Epoxy Coated per ICC-ES AC228 (EP)
Compatibility	MH3521, MH3530
Capacity	
Ultimate Compression/ Tension	16 Tons / 16 Tons
Allowable Compression/ Tension	8 Tons / 8 Tons

Notes: Cap capacity is developed using the ASD design method and considers strength of collar, end effector, and pile connection. Capacity may be limited by the helical pile itself, bearing/pullout capacity of soil, or strength of the structure to which the cap is attached. Strength of the structure may be limited by crushing strength, span or bolt bearing on the wood beam.



Installation Notes: After installation of a MAGNUM® Helical Pile to the correct depth, torque, and capacity, cut-off the pile shaft at the proper elevation. Drill (1) 1-1/16" holes using a MAGNUM® drill template. Place the pile cap over the shaft and secure with (1) 1" bolt. Snug tighten nut. Place wood beams on cap angle and secure with 1/2" lag bolts as required for the project.



Lag Bolts Sold Separately

MAGNUM®
P I E R I N G
designed to support

156 Circle Freeway Dr.
Cincinnati, OH 45246
800-822-7437
www.MagnumPiering.com

MAGNUM® MHC1160-3B 4x4 Post Cap

Allowable Capacity 8 Tons Compression / 8 Tons Tension

2" Tall 3-5/8" x 3-5/8" x 3/16" Post Base & 3.13-Inch I.D. Collar
 Fits MH313B, MH313BR & MH325B Helical Piles

Description: MAGNUM® Wood Post Caps consist of a collar tube with bolt hole for connection to MAGNUM® Helical Piles and a pair of angles for attachment to the base of a wood post. MAGNUM® products are manufactured in the USA according to our ISO 9001 approved quality program. Structural capacities are developed according to AISC 360 considering an average design life of 75 years for bare steel in most soil conditions. Hot-dip galvanizing is available upon request. Design and detailing of the structure, to which bearing plate cap is attached varies by project and is the responsibility of the registered design professional including crushing strength, lateral bracing, and span of wood post.

Specifications	
Collar Tube	0.25" x 3.13" I.D. ASTM A513, Fy = 65 ksi or Better
End Effector	2" tall 3-5/8" x 3-5/8" x 3/16" Post Base with Holes for (6) 1/4" Lag Bolts
Pile Connection	(1) 7/8" SAE J429 Grade 5 Zinc Coated to ASTM B695/F1941
Coating	Galvanized per ASTM A153/A123 (G), Bare Steel (NG), or Epoxy Coated per ICC-ES AC228 (EP)
Compatibility	MH313B, MH313BR, MH325B
Capacity	
Ultimate Compression/Tension	17 Tons / 17 Tons
Allowable Compression/Tension	8 Tons / 8 Tons

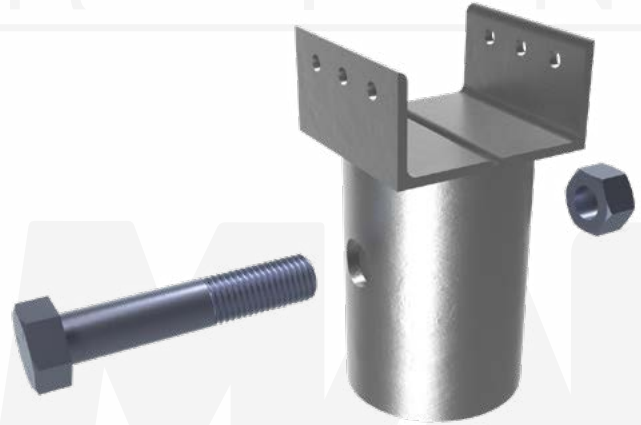

Notes: Cap capacity is developed using the ASD design method and considers strength of collar, end effector, and pile connection. Capacity may be limited by the helical pile itself, bearing/pullout capacity of soil, or strength of the structure to which the cap is attached. Strength of the structure may be limited by crushing strength, span or bolt bearing on the wood column.



Installation Notes: After installation of a MAGNUM® Helical Pile to the correct depth, torque, and capacity, cut-off the pile shaft at the proper elevation. Drill (1) 15/16" hole using a MAGNUM® drill template. Place the pile cap over the shaft and secure with (1) 7/8" bolt. Snug tighten nut. Place wood post on post base and secure with 1/4" lag bolts as required for the project.

Lag Bolts Sold Separately



156 Circle Freeway Dr.
 Cincinnati, OH 45246
 800-822-7437
www.MagnumPiering.com

WOOD

MAGNUM® MHC1160-35B 4x4 Post Cap

Allowable Capacity 8 Tons Compression / 8 Tons Tension

2" Tall 3-5/8" x 3-5/8" x 3/16" Post Base & 3.63-Inch I.D. Collar
Fits MH3521 & MH3530 Helical Piles

Description: MAGNUM® Wood Post Caps consist of a collar tube with bolt hole for connection to MAGNUM® Helical Piles and a pair of angles for attachment to the base of a wood post. MAGNUM® products are manufactured in the USA according to our ISO 9001 approved quality program. Structural capacities are developed according to AISC 360 considering an average design life of 75 years for bare steel in most soil conditions. Hot-dip galvanizing is available upon request. Design and detailing of the structure, to which bearing plate cap is attached varies by project and is the responsibility of the registered design professional including crushing strength, lateral bracing, and span of wood post.

Specifications	
Collar Tube	0.31" x 3.63" I.D. ASTM A513, Fy = 65 ksi or Better
End Effector	2" tall 3-5/8" x 3-5/8" x 3/16" Post Base with Holes for (6) 1/4" Lag Bolts
Pile Connection	(1) 1" SAE J429 Grade 8 Zinc Coated to ASTM B695/F1941
Coating	Galvanized per ASTM A153/A123 (G), Bare Steel (NG), or Epoxy Coated per ICC-ES AC228 (EP)
Compatibility	MH3521, MH3530
Capacity	
Ultimate Compression/ Tension	17 Tons / 17 Tons
Allowable Compression/ Tension	8 Tons / 8 Tons

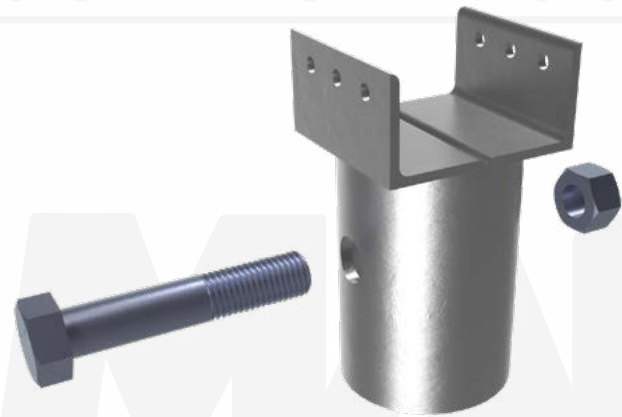

Notes: Cap capacity is developed using the ASD design method and considers strength of collar, end effector, and pile connection. Capacity may be limited by the helical pile itself, bearing/pullout capacity of soil, or strength of the structure to which the cap is attached. Strength of the structure may be limited by crushing strength, span or bolt bearing on the wood column.



Installation Notes: After installation of a MAGNUM® Helical Pile to the correct depth, torque, and capacity, cut-off the pile shaft at the proper elevation. Drill 1-1/16" hole using a MAGNUM® drill template. Place the pile cap over the shaft and secure with (1) 1" bolt. Snug tighten nut. Place wood post on post base and secure with 1/4" lag bolts as required for the project.

Lag Bolts Sold Separately

MAGNUM®
P I E R I N G
designed to support

156 Circle Freeway Dr.
Cincinnati, OH 45246
800-822-7437
www.MagnumPiering.com

MAGNUM® MHC1161-3B 6x6 Post Cap

Allowable Capacity 16 Tons Compression / 16 Tons Tension

3" Tall 5-5/8" x 5-5/8" x 1/4" Post Base & 3.13-Inch I.D. Collar
 Fits MH313B, MH313BR & MH325B Helical Piles

Description: MAGNUM® Wood Post Caps consist of a collar tube with bolt hole for connection to MAGNUM® Helical Piles and a pair of angles for attachment to the base of a wood post. MAGNUM® products are manufactured in the USA according to our ISO 9001 approved quality program. Structural capacities are developed according to AISC 360 considering an average design life of 75 years for bare steel in most soil conditions. Hot-dip galvanizing is available upon request. Design and detailing of the structure, to which bearing plate cap is attached varies by project and is the responsibility of the registered design professional including crushing strength, lateral bracing, and span of wood post.

Specifications	
Collar Tube	0.25" x 3.13" I.D. ASTM A513, Fy = 65 ksi or Better
End Effector	3" tall 5-5/8" x 5-5/8" x 1/4" Post Base with Holes for (6) 1/2" Lag Bolts
Pile Connection	(1) 7/8" SAE J429 Grade 5 Zinc Coated to ASTM B695/F1941
Coating	Galvanized per ASTM A153/A123 (G), Bare Steel (NG), or Epoxy Coated per ICC-ES AC228 (EP)
Compatibility	MH313B, MH313BR, MH325B
Capacity	
Ultimate Compression/Tension	32 Tons / 32 Tons
Allowable Compression/Tension	16 Tons / 16 Tons

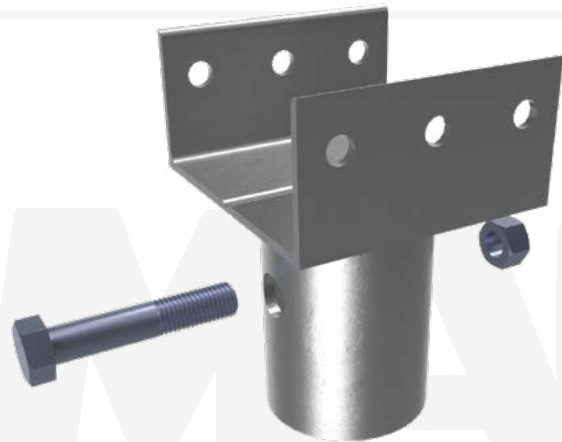

Notes: Cap capacity is developed using the ASD design method and considers strength of collar, end effector, and pile connection. Capacity may be limited by the helical pile itself, bearing/pullout capacity of soil, or strength of the structure to which the cap is attached. Strength of the structure may be limited by crushing strength, span or bolt bearing on the wood column.



Installation Notes: After installation of a MAGNUM® Helical Pile to the correct depth, torque, and capacity, cut-off the pile shaft at the proper elevation. Drill (1) 15/16" hole using a MAGNUM® drill template. Place the pile cap over the shaft and secure with (1) 7/8" bolt. Snug tighten nut. Place wood post on post base and secure with 1/2" lag bolts as required for the project.

Lag Bolts Sold Separately



156 Circle Freeway Dr.
 Cincinnati, OH 45246
 800-822-7437
www.MagnumPiering.com

WOOD

MAGNUM® MHC2161-3T1 6x6 Post Clamp Cap

Allowable Capacity 16 Tons Compression / 0.5 Tons Tension

3" Tall 5-5/8" x 5-5/8" x 1/4" Post Base & 3.13-Inch I.D. Collar
Fits MH313B, MH313BR, MH325B & MH325BR(-6) Helical Piles

Description: MAGNUM® Wood Post Caps consist of a collar tube with bolt hole for connection to MAGNUM® Helical Piles and a pair of angles for attachment to the base of a wood post. MAGNUM® products are manufactured in the USA according to our ISO 9001 approved quality program. Structural capacities are developed according to AISC 360 considering an average design life of 75 years for bare steel in most soil conditions. Hot-dip galvanizing is available upon request. Design and detailing of the structure, to which bearing plate cap is attached varies by project and is the responsibility of the registered design professional including crushing strength, lateral bracing, and span of wood post.

Specifications	
Collar Tube	0.25" x 3.13" I.D. ASTM A513, Fy = 65 ksi or Better
End Effector	3" tall 5-5/8" x 5-5/8" x 1/4" Post Base with Holes for (6) 1/2" Lag Bolts
Pile Connection	(1) 3/4"-16 SAE J429 Grade 8 Zinc Coated to ASTM B695/F1941 Installation Torque 50 ft-lb min, 60ft-lb max
Coating	Galvanized per ASTM A153/A123 (G), Bare Steel (NG), or Epoxy Coated per ICC-ES AC228 (EP)
Compatibility	MH313B, MH313BR, MH325B, MH325BR(-6)
Capacity	
Ultimate Compression/ Tension	32 Tons / 1 Ton
Allowable Compression/ Tension	16 Tons / 0.5 Tons

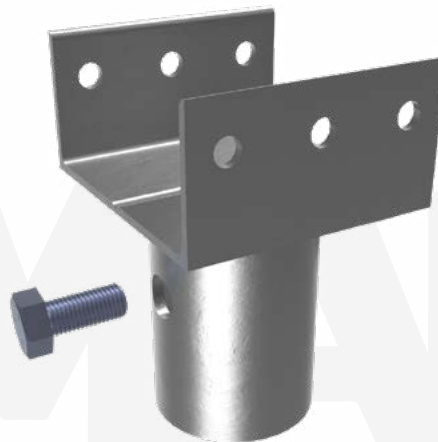

Notes: Cap capacity is developed using the ASD design method and considers strength of collar, end effector, and pile connection. Capacity may be limited by the helical pile itself, bearing/pullout capacity of soil, or strength of the structure to which the cap is attached. Strength of the structure may be limited by crushing strength, span or bolt bearing on the wood column.



Installation Notes: Protect pile cap and bolt from weather prior to installation. After installation of a MAGNUM® Helical Pile to the correct depth, torque, and capacity, cut-off the pile shaft square at the proper elevation. Place the pile cap over the shaft and secure with (1) 3/4"-16 bolt. Ensure direct bearing of post base on shaft. Tighten bolt to a minimum torque of 50 ft-lbs. Do not exceed 60 ft-lbs. Place wood post and fasten with 1/2" lag screws.

* Post base must directly bear on shaft for compression capacity shown.
** Bolts must be new, clean, dry and free of any dust, rust or paint. Threaded holes must be clean, dry and free of any surface dust, rust, paint, or galvanizing for tension capacity shown. Manufacture applied lubricating wax on bolts is acceptable.

Lag Bolts Sold Separately

MAGNUM®
P I E R I N G
designed to support

156 Circle Freeway Dr.
Cincinnati, OH 45246
800-822-7437
www.MagnumPiering.com

MAGNUM® MHLS1000 Boardwalk K-Bracing System

Allowable Lateral Capacity 2 Tons*

2" x 2" x 1/16" Angles with Plate Steel Bracket Connections

Description: The MAGNUM® MHLS1000 Boardwalk K-Bracing System consists of 2" x 2" x 1/16" steel angles with 3" x 3" steel angle brackets for connection to MAGNUM® MH313 and MH325 helical pile shafts. Sold separately are MHC1122 and MHC1123 steel angle caps that attach top of helical piles to dimension lumber, engineered wood, or rough timber cross beam. The K-brace system is easier to install, more economical, and generally performs better than the H-brace system. It can accommodate 4 ft to 12 ft wide boardwalks with clear heights above ground from 12" to 48". K-Braces can be used for boardwalks above this height, but Magnum generally recommends adding MAGNUM® helical anchors as tie-backs at a 45 deg angle at 16 to 24 ft on-center along the length of the boardwalk for improved lateral performance. Custom K-brace sizes are available for wider or narrower boardwalks. K-braces provide lateral resistance and sideways stabilization. Each brace is fastened to wooden cross beam with (2) lag bolts. Opposite end of angle braces are affixed to pile shafts using Hilti PAF fasteners. The entire assembly can be hot-dip galvanized for increased corrosion resistance.



Features:

*Easier to Install, More Economical, and More Rigid than MHLS1005 H-Brace and Similar Competitors Systems

U.S. Patent Pending

Installation Note: Layout and install boardwalk pile foundations. Cut-off pile shafts at required elevation. Mount wood beam support brackets to tops of piles (sold separately). Place wood cross beam. Install angle K-braces. Overlap K-braces by placing them on opposite sides of cross beam for shorter spans. Adjust K-brace location so bottom bracket is approximately 6 to 12 inches above grade.

*Lateral capacity is based on maximum structural resistance. Lateral capacity of brace/pile system depends on ground conditions and should be determined by a design professional for the specific job site and subsurface conditions. Contact Magnum technical support for design assistance.

MAGNUM®
P I E R I N G
designed to support

Page - 231

Rev. 11-4-2025 | Copyright (C) 2016-2025 All Rights Reserved

MAGNUM® MHLS1005 Boardwalk H-Bracing System

Allowable Lateral Capacity 2 Tons*

3" Diameter Cross Tube with 3.5" I.D. Collars and Angle Bracket Connections

Description: The MAGNUM® MHLS1005 Boardwalk H-Bracing System consists of a 3.0" O.D. cross tube with 3.5" I.D. collar tubes for connection to MAGNUM® MH3521 helical pile shafts and steel angle brackets for connection to a dimension lumber, engineered wood, or rough timber cross beam. The H brace system can accommodate 6 ft and 8 ft wide boardwalks with clear heights above ground from 24" to 48". H-Braces can be used for boardwalks above this height, but Magnum® generally recommends adding MAGNUM® helical anchors as tie-backs at a 45 deg angle at 16 to 24 ft on center along the length of the boardwalk for improved lateral performance. Custom H-brace sizes are available for narrower or wider boardwalks. H-braces provide lateral resistance and sideway stabilization. Each plate steel bracket is fastened to wooden cross beam with (4) ½" lag bolts. Collar tubes are fastened to helical pile shaft using (1) 1" diameter through bolt on each side. The entire assembly can be hot-dip galvanized for increased corrosion resistance.



Installation Note: Layout and install MH3521 helical pile foundations for boardwalk bents. Cut-off helical pile shafts at required elevation. Drill holes in pile shaft to facilitate attachment to H-brace. Mount H-brace to tops of piles and secure with through bolts. Place wood cross beam and attach with lag bolts.

*Lateral capacity is based on maximum structural resistance. Lateral capacity of brace/pile system depends on ground conditions and should be determined by a design professional for the specific job site and subsurface conditions. Contact Magnum technical support for design assistance.

Helical Post Bases



Helical Post Base Product Number Specification Legend

Example

The MAGNUM® Helical Post Base product number below, MBS8S-6K6S8SG is for an 8.63" diameter casing that is 6 ft long with (2) 0.375" single edge helices 6 and 8 inches in diameter, and the surface preparation is Galvanized.

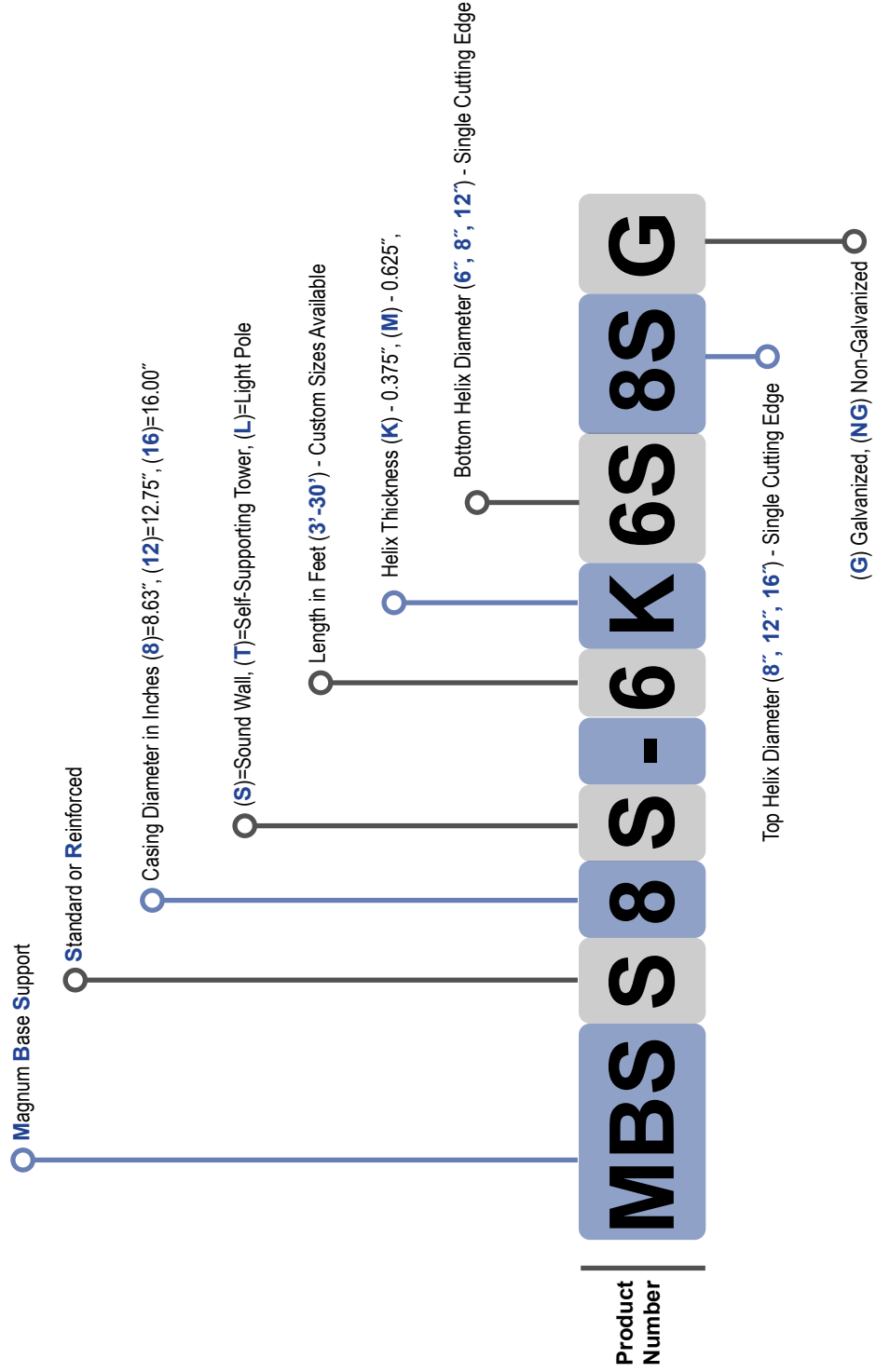

Helical Post Bases



System Ratings & Specifications

Post Bases	Shaft Design Wall Gauge (in)	Shaft O.D. (in)	Casing Design Wall Gauge (in)	Casing O.D. (in)	Allowable Torque (ft-lbs)	Flexural Strength				Helix Sizes (single edge helix) (in)	Helix Gauge (in)	Surface Coating**	Standard Lengths (custom sizes available) (ft)	Schematic
						Standard		With Slot						
						Ultimate (kip-ft)	Allowable (kip-ft)	Ultimate (kip-ft)	Allowable (kip-ft)					
MBSS8	0.125	3	0.109	8.63	14,000	27	16	22	13	8S, 6S	0.375	G, NG	3-10	
MBSS12	0.25	3	0.109	12.75	30,000	57	34	50	30	12S, 8S	0.375	G, NG	6-20	
MBSS16	0.25	4.5	0.109	16	53,000	87	52	78	47	16S, 12S	0.625	G, NG	10-30	
MBSR8	0.125	3	0.25	8.63	16,000	70	42	57	34	8S, 6S	0.375	G, NG	3-10	
MBSR12	0.25	3	0.25	12.75	30,000	138	83	130	78	12S, 8S	0.375	G, NG	6-20	
MBSR16	0.25	4.5	0.25	16	68,000	227	136	205	123	16S, 12S	0.625	G, NG	10-30	

Notes:

*Lateral capacity is approximate and based on stiff clay or medium sand (SPT N>10) or better soils. Theoretical deflection is limited to 3" or less at the pile head. Lateral load is applied at distance shown above ground surface (a.g.s.). Contact Magnum's technical support and engineering team for site specific solar pile designs.

**G = Hot-Dip Galvanized per ASTM A123/A153, NG = Bare Steel

Most MAGNUM® helical pile products are manufactured using minimum 65 ksi minimum yield strength structural tubing, or better, for the shaft and ASTM A36 plate steel, or better, for the helical bearing plates. As MAGNUM® is committed to testing and improving products, these specifications are subject to change. Additional product specifications available at www.magnumpiling.com and in the MAGNUM® Helical Pile Engineering Reference Manual available upon request. Structural capacity is for piles in firm soil with fully braced pile cap. Structural capacity takes into account corrosion over IBC design life in moderate to high corrosive soils based on ICC-ES AC308. Consult a MAGNUM® corrosion engineer for severely corrosive soils.

MAGNUM® MBS Helical Post Bases

Introduction

8" to 16" Dia. x 3 to 30 ft Long Steel Casing
for Support of Soundwalls, Light Posts, and Towers

Description: The MAGNUM® MBS Helical Post Base foundation consists of a variable length, large diameter steel casing encircling a smaller diameter central shaft with two helical bearing plates. The central shaft extends beyond the bottom of the casing a distance of several feet as a guide to maintain plumbness during installation. The casing is welded to a top plate with slotted bolt-hole pattern. The entire foundation is screwed into the ground to a depth at which the top plate is positioned slightly below the ground surface. The top plate accommodates attachment of various structures.

Helical foundations can significantly reduce construction cost and schedule time, because they can be installed in a fraction of the time required for drilled shafts. The use of helical foundations also improves traffic safety, because they eliminate the need for concrete curing and redundant traffic control. Helical foundations can be installed in areas with limited access, install easily through groundwater, and do not produce drill spoil. These features make them particularly attractive alternatives for congested metropolitan areas and environmentally contaminated sites. Helical post base foundations are installed using a hydraulic torque motor mounted to an excavator or derrick truck. Installation can generally be completed in minutes. The helices displace the soil with minimal disturbance much like a screw. The casing fills with soil during installation so as to resist crushing under external earth pressures. Several sizes are offered at 1 foot increments. Custom sizes are available for special cases.

The MBS Helical Post Base is capable of penetrating very stiff clays, dense sands and gravels, and even medium hard, highly weathered, sedimentary bedrock formations. MBS foundations are not applicable in soils characterized by a SPT blow count of more than 50 for 6 inches, hard bedrock, or soils with cobble and boulders. The size of helical post bases are typically governed by the overturning moment. Below is a table with preliminary sizing. Magnum's technical support professionals can assist with sizing recommendations and for a small fee can provide a complete engineering report for specific job sites. Bearing and pullout capacity can be checked using helical sizing charts or by traditional geotechnical calculations.

		Cohesive Soils				Non-Cohesive Soils			
		Soft	Medium	Stiff	Very Stiff	Loose	Medium	Dense	Very Dense
		Standard Penetration Test Blow Count (bpf)							
		2 - 4	4 - 8	8 - 15	>15	4 - 10	10 - 30	30 - 50	>50
		Cohesive (psf)				Angle Of Internal Friction (deg)			
		400	800	1500	3000	29	33	39	45
		Preliminary MBS Sizing							
Overturning Moment (kip-ft)	5	MBSS8-7	MBSS8-5	MBSS8-3	MBSS8-3	MBSS8-7	MBSS8-7	MBSS8-5	MBSS8-4
	10	MBSS12-10	MBSS12-6	MBSS8-5	MBSS8-4	MBSR8-10	MBSR8-9	MBSR8-7	MBSR8-6
	15	MBSS12-13	MBSS12-8	MBSR8-7	MBSR8-4	MBSR12-11	MBSR12-9	MBSS12-8	MBSR8-7
	20	MBSR12-16	MBSR12-10	MBSS12-7	MBSR8-5	MBSR12-12	MBSR12-10	MBSR12-9	MBSR12-7
	25	MBSR12-19	MBSR12-12	MBSR12-8	MBSR12-5	MBSR12-13	MBSR12-11	MBSR12-9	MBSR12-8
	30	MBSR16-19	MBSR12-13	MBSR12-9	MBSR12-6	MBSR16-13	MBSR16-11	MBSR12-10	MBSR12-8
	35	MBSR16-21	MBSR16-13	MBSR12-10	MBSR12-6	MBSR16-14	MBSR16-12	MBSR16-10	MBSR12-9
	40	N/A	MBSR16-14	MBSR12-11	MBSR12-7	N/A	MBSR16-13	MBSR16-10	MBSR16-9
	45		MBSR16-16	MBSR16-10	MBSR12-7		N/A	MBSR16-11	MBSR16-9
	50		N/A	MBSR16-11	MBSR16-7			N/A	MBSR16-9
	55			MBSR16-12	MBSR16-7				N/A
	60			N/A	MBSR16-8				
	65				MBSR16-8				
	70				MBSR16-9				
	75				N/A				



MAGNUM® MBSS#S Helical Post Base

Standard Capacity Sound Wall Foundation

8" to 16" Ø x 3 to 30 ft Long Steel Casing

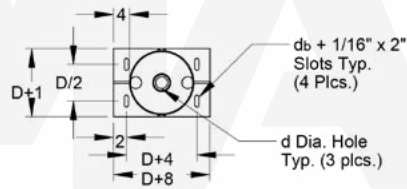

SECTION A-A

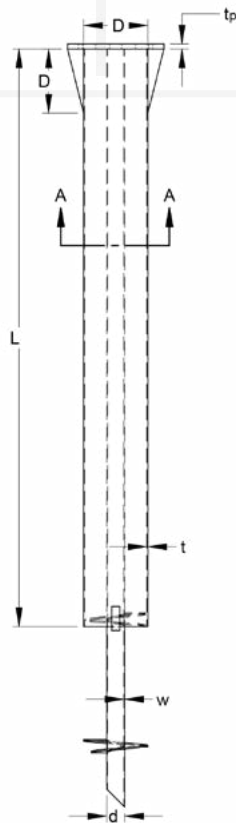

Description: MAGNUM® MBSS#S Helical Post Base is a full displacement deep foundation for support of sound walls, light poles, signs, towers and other structures where the primary loading condition is overturning or lateral shear. The standard capacity offers greater economy for many applications. Helical Post Bases offer all the advantages of a helical foundation in that they do not produce drill spoil or cause vibrations during installation. They do not require concrete and the sign, light post, or other structure can be mounted to the foundation immediately after installation. They are ideal for rail corridors, rural areas, along highways, and near bridge/overpass approaches. Slotted top plate and four bolt moment connection allows adjustment in position and inclination. Patented design with novel geometry and side cutting teeth reduces installation torque and improves penetration into tough ground conditions. See accompanying sizing chart or contact a Magnum Technical Support representative for help with sizing and specification.

Note: All plate steel is ASTM A36, central steel shaft is ASTM A513, and outer steel casing is ASTM A252. Available hot-dip galvanized (G) or bare steel (NG). Capacities shown are based on 75 yr corrosion with galvanization

Specifications									Allowable Capacity				
Post Base Size	Steel Casing			Helix Gauge	Shaft		Top Plate	Bolt Dia.	Flexure		Shear		Allow Torque
	Length	O.D.	Gauge		Dia.	Gauge			Std.	w/slot	Std.	w/slot	
	L	D	t	T	d	w	t _p	d _b	kip-ft	kip-ft	kips	kips	ft-lbs
MBSS8S	3'-10'	8.625"	0.109"	3/8"	3.00"	0.13"	5/8"	5/8"	16	13	24	20	14,000
MBSS12S	6'-20'	12.75"	0.109"	3/8"	3.00"	0.25"	3/4"	3/4"	34	30	35	31	30,000
MBSS16S	10'-30'	16.00"	0.109"	5/8"	4.50"	0.25"	7/8"	1"	52	47	44	40	53,000



156 Circle Freeway Dr.
Cincinnati, OH 45246
800-822-7437
www.MagnumPiering.com

MAGNUM® MBSR#S Helical Post Base

Standard Capacity Sound Wall Foundation

8" to 16" Ø x 3 to 30 ft Long Steel Casing

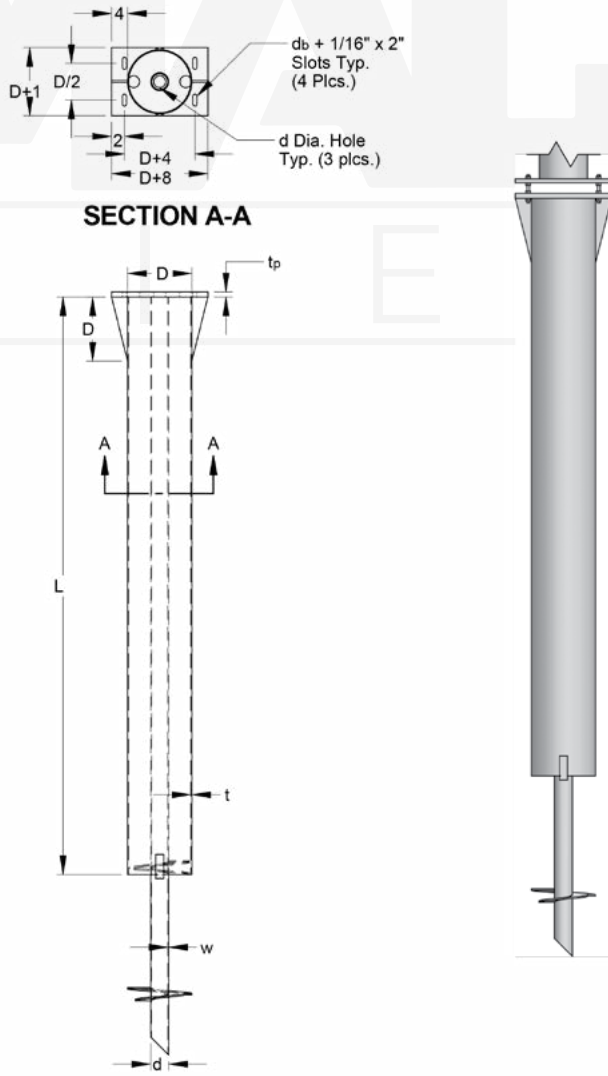

Description: MAGNUM® MBSR#S Helical Post Base is a full displacement deep foundation for support of sound walls, light poles, signs, towers and other structures where the primary loading condition is overturning or lateral shear. The standard capacity offers greater economy for many applications. Helical Post Bases offer all the advantages of a helical foundation in that they do not produce drill spoil or cause vibrations during installation. They do not require concrete and the sign, light post, or other structure can be mounted to the foundation immediately after installation. They are ideal for rail corridors, rural areas, along highways, and near bridge/overpass approaches. Slotted top plate and four bolt moment connection allows adjustment in position and inclination. Patented design with novel geometry and side cutting teeth reduces installation torque and improves penetration into tough ground conditions. See accompanying sizing chart or contact a Magnum Technical Support representative for help with sizing and specification.

Note: All plate steel is ASTM A36, central steel shaft is ASTM A513, and outer steel casing is ASTM A252. Available hot-dip galvanized (G) or bare steel (NG). Capacities shown are based on 75 yr corrosion with galvanization

Specifications									Allowable Capacity				
Post Base Size	Steel Casing			Helix Gauge	Shaft		Top Plate	Bolt Dia.	Flexure		Shear		Allow Torque
	Length	O.D.	Gauge		Dia.	Gauge			Std.	w/slot	Std.	w/slot	
	L	D	t		T	d			w	t_p	d_b	kip-ft	
MBSR8S	3'-10"	8.625"	0.250"	3/8"	3.00"	0.13"	5/8"	5/8"	42	34	43	43	16,000
MBSR12S	6'-20"	12.75"	0.250"	3/8"	3.00"	0.25"	3/4"	3/4"	83	78	63	63	30,000
MBSR16S	10'-30"	16.00"	0.250"	5/8"	4.50"	0.25"	7/8"	1"	136	123	106	96	68,000



156 Circle Freeway Dr.
Cincinnati, OH 45246
800-822-7437
www.MagnumPiering.com

MAGNUM® MBSS#T Helical Post Base

Self Supporting Tower Foundation

8" and 12" Ø x 5 to 12 ft Long Steel Casing

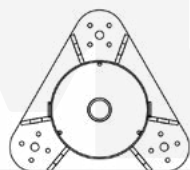

MBSS12

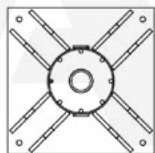

MBSS8

SECTION A-A

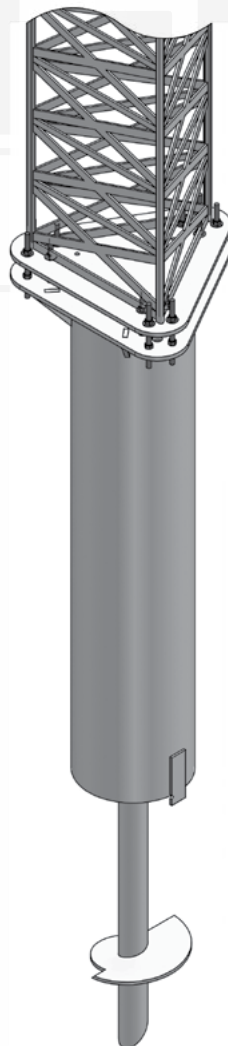
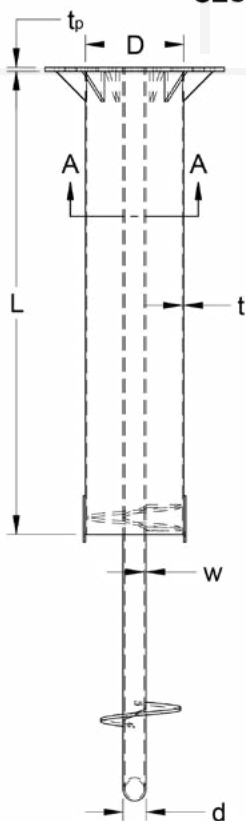

Description: MAGNUM® MBSS#T Helical Post Base is a full displacement deep foundation for support of sound walls, light poles, signs, towers and other structures where the primary loading condition is overturning or lateral shear. The standard capacity offers greater economy for many applications. Helical Post Bases offer all the advantages of a helical foundation in that they do not produce drill spoil or cause vibrations during installation. They do not require concrete and the sign, light post, or other structure can be mounted to the foundation immediately after installation. They are ideal for rail corridors, rural areas, along highways, and near bridge/overpass approaches. Bolted top plate moment connection allows adjustment in position and inclination. Patented design with novel geometry and side cutting teeth reduces installation torque and improves penetration into tough ground conditions. See accompanying sizing chart or contact a Magnum Technical Support representative for help with sizing and specification.

Note: All plate steel is ASTM A36, central steel shaft is ASTM A513, and outer steel casing is ASTM A252. Available hot-dip galvanized (G) or bare steel (NG). Capacities shown are based on 75 yr corrosion with galvanization

Specifications									Allowable Capacity				
Post Base Size	Steel Casing			Helix Gauge	Shaft		Top Plate	Bolt Dia.	Flexure		Shear		Allow Torque
	Length	O.D.	Gauge		Dia.	Gauge			Std.	w/slot	Std.	w/slot	
	L	D	t		T	d			w	t _p	d _b	kip-ft	
MBSS8T	5'	8.625"	0.109"	3/8"	3.00"	0.13"	1/2"	5/8"	16	13	24	20	14,000
MBSS12T	5'-12'	12.75"	0.109"	3/8"	3.00"	0.25"	1/2"	3/4"	34	30	35	31	30,000



156 Circle Freeway Dr.
Cincinnati, OH 45246
800-822-7437
www.MagnumPiering.com

MAGNUM® MBSS#L Helical Post Base

Light Pole Foundation

16" Ø x 11 ft Long Steel Casing

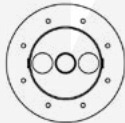

SECTION A-A

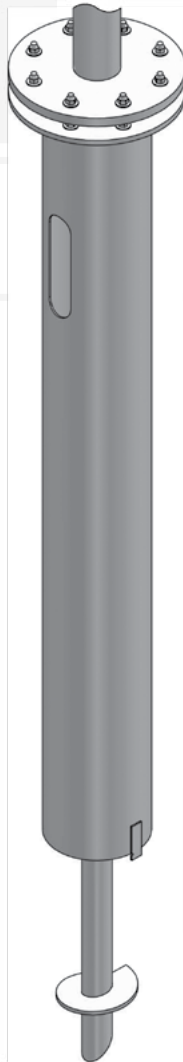
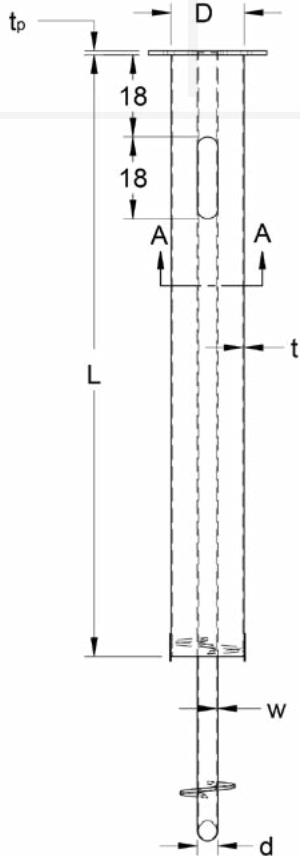

Description: MAGNUM® MBSS#L Helical Post Base is a full displacement deep foundation for support of sound walls, light poles, signs, towers and other structures where the primary loading condition is overturning or lateral shear. The standard capacity offers greater economy for many applications. Helical Post Bases offer all the advantages of a helical foundation in that they do not produce drill spoil or cause vibrations during installation. They do not require concrete and the sign, light post, or other structure can be mounted to the foundation immediately after installation. They are ideal for rail corridors, rural areas, along highways, and near bridge/overpass approaches. Bolted top plate moment connection allows adjustment in position and inclination. Patented design with novel geometry and side cutting teeth reduces installation torque and improves penetration into tough ground conditions. See accompanying sizing chart or contact a Magnum Technical Support representative for help with sizing and specification.

Note: All plate steel is ASTM A36, central steel shaft is ASTM A513, and outer steel casing is ASTM A252. Available hot-dip galvanized (G) or bare steel (NG). Capacities shown are based on 75 yr corrosion with galvanization

Specifications									Allowable Capacity				
Post Base Size	Steel Casing			Helix Gauge	Shaft		Top Plate	Bolt Dia.	Flexure		Shear		Allow Torque
	Length	O.D.	Gauge		Dia.	Gauge			Std.	w/slot	Std.	w/slot	
	L	D	t		T	d			w	t _p	d _b	kip-ft	
MBSS16L	10'-30"	16.00"	0.109"	5/8"	4.50"	0.25"	7/8"	1"	52	47	44	40	53,000



156 Circle Freeway Dr.
Cincinnati, OH 45246
800-822-7437
www.MagnumPiering.com

MAGNUM® Direct Embed Pile

Up to 300 kip-ft Ground Line Moment

Cohesive Soil

Description: MAGNUM® Direct Embed Piles (MDEP) are manufactured in the USA according to our ISO 9001 approved Quality Program. For sites with Cohesive soils the chart and table below can be utilized to estimate the minimum bucket and shaft length of MDEP. Using the Ground Line Moment (GLM) and soil type in the graph to estimate the minimum bucket length, then add it to the shaft length from the table based on the ANSI pole classification for the total estimated length. Install MDEPs to the required depth. Hot-dip galvanized coating, custom lengths, diameters and configurations available upon request.

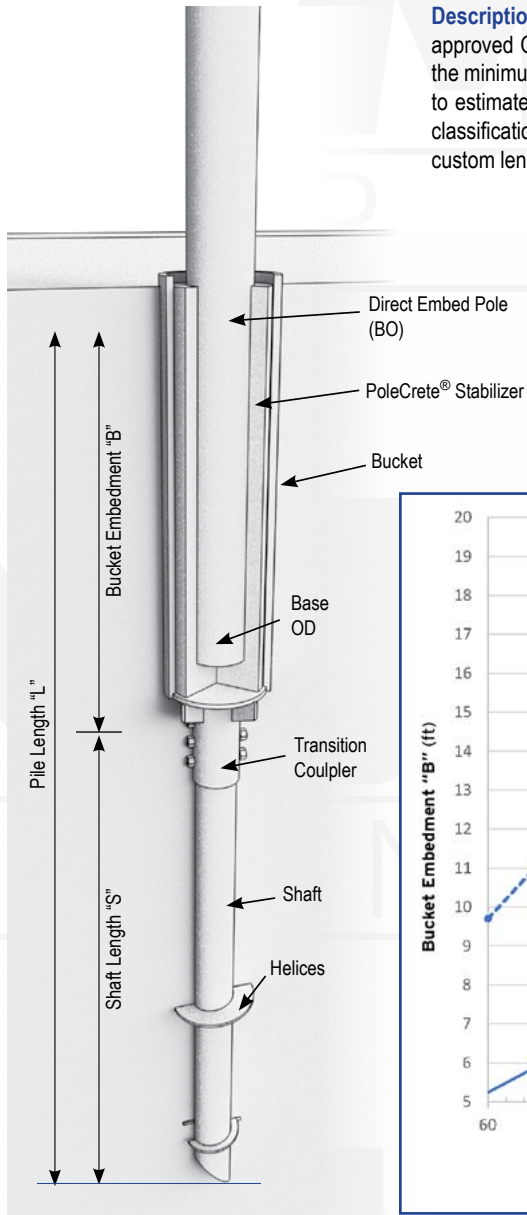

Shaft Length "S" (ft)			
ANSI Pole Class	Very Soft Clay	Soft Clay	Medium Clay
C1, C2 & H1	20	17	10
*H2, H3 & H4	N/A		

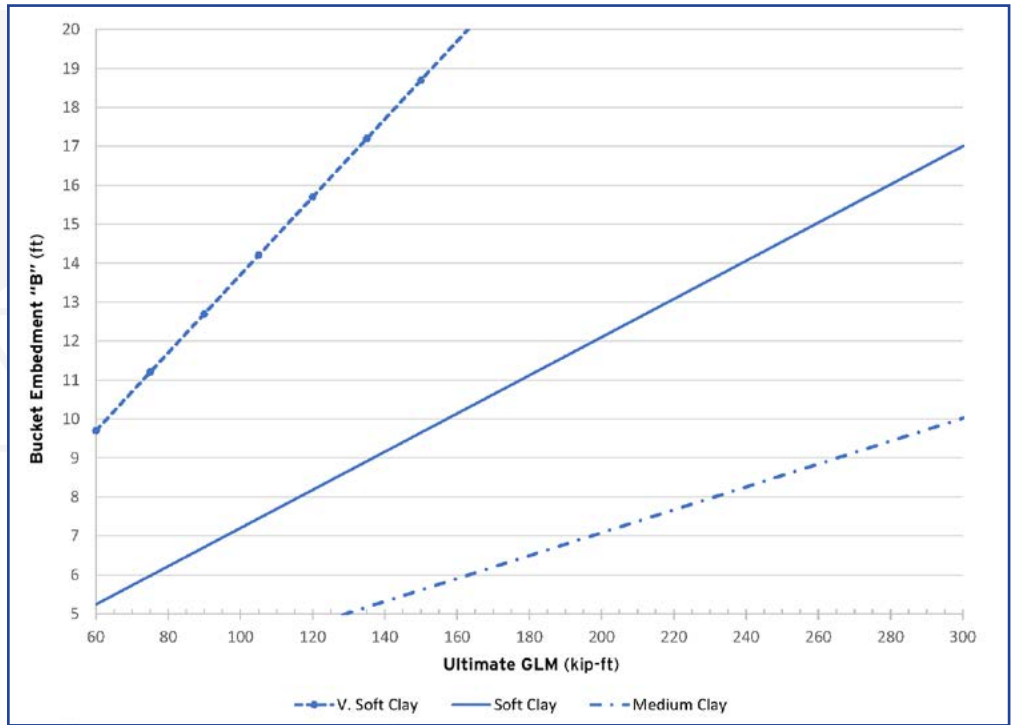

Index Soil Properties	Cohesive Soils		
	Very Soft	Soft	Medium
SPT Blow Count (bpf)	1-2	2-4	4-8
Strain, E ₅₀	0.06	0.02	0.01
p-y Modulus (pci)	30	100	500
Cohesion (psf)	200	400	800
Friction Angle (deg)	0	0	0
Unit Weight (pcf)	80	85	90

Notes: MAGNUM® Direct Embed Piles shall be installed to the appropriate bucket embedment depth as determined by geotechnical engineer or local practice. Place and secure pole into the bucket using Polecrete® Stabilizer. Mix and place stabilizer according to manufacturer's recommendations.



156 Circle Freeway Dr.
Cincinnati, OH 45246
800-822-7437
www.MagnumPiering.com

MAGNUM® Direct Embed Pole

Up to 300 kip-ft Ground Line Moment

Non-Cohesive Soil

Description: MAGNUM® Direct Embed Piles (MDEP) are manufactured in the USA according to our ISO 9001 approved Quality Program. For sites with Non-Cohesive soils the chart and table below can be utilized to estimate the minimum bucket and shaft length of MDEP. Using the Ground Line Moment (GLM) and soil type in the graph to estimate the minimum bucket length, then add it to the shaft length from the table based on the ANSI pole classification for the total estimated length. Install MDEPs to the required depth. Hot-dip galvanized coating, custom lengths, diameters and configurations available upon request.

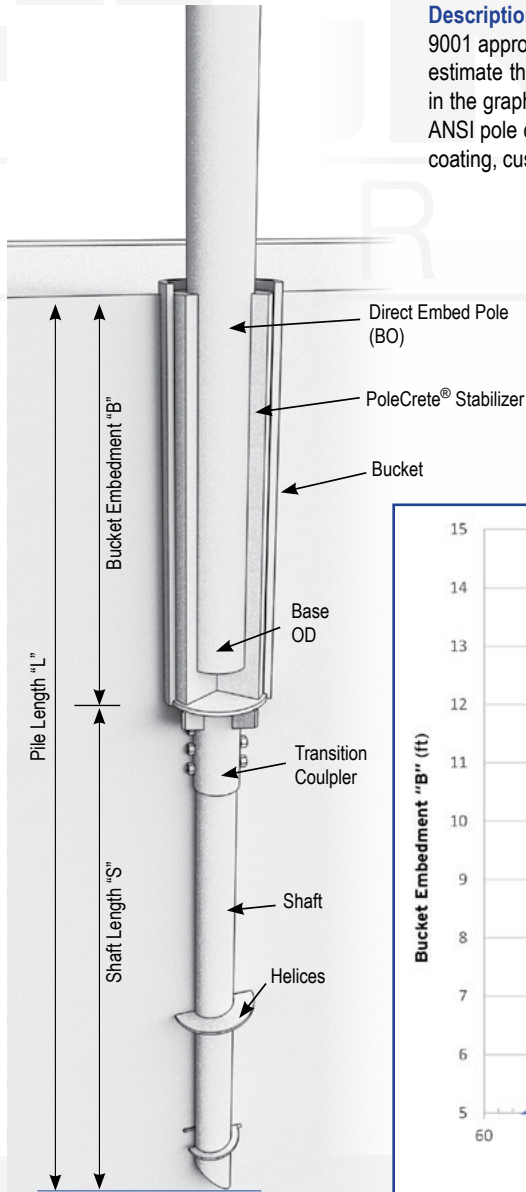

Shaft Length "S" (ft)			
ANSI Pole Class	Very Loose Sand	Loose Sand	Medium Sand
C1, C2, H1 H2, H3 & H4	12	9	7

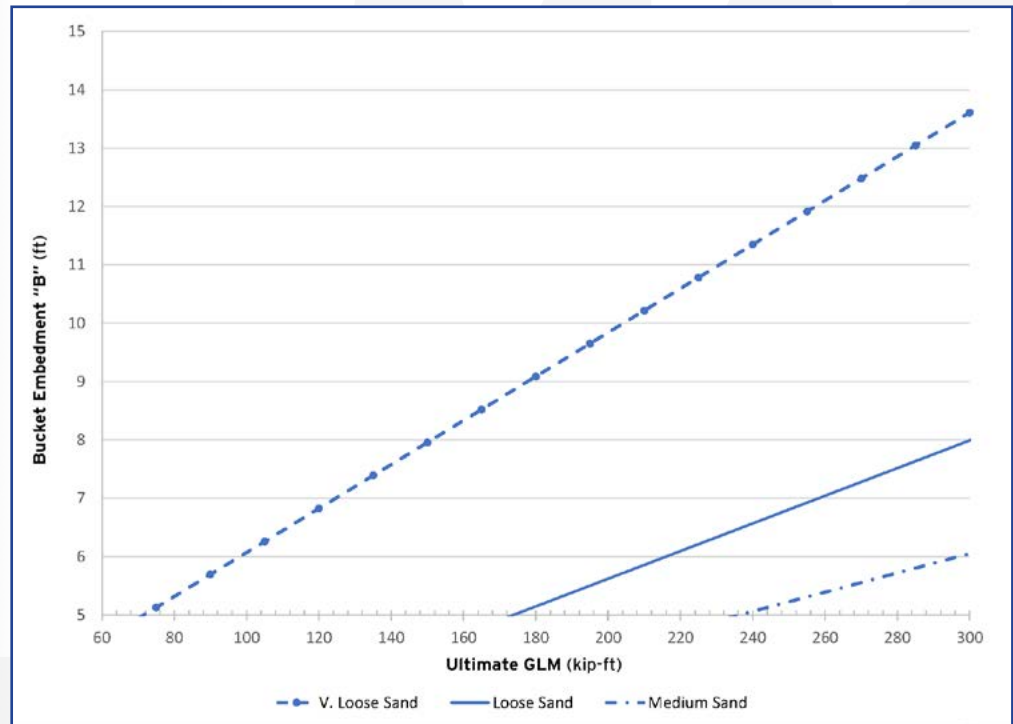

Index Soil Properties	Non-Cohesive Soils		
	Very Loose Sand	Loose Sand	Medium Sand
SPT Blow Count (bpf)	1-4	4-10	10-30
Strain, E_{50}	N/A	N/A	N/A
p-y Modulus (pci)	5	25	90
Cohesion (psf)	0	0	0
Friction Angle (deg)	25	29	33
Unit Weight (pcf)	70	90	110

Notes: MAGNUM® Direct Embed Piles shall be installed to the appropriate bucket embedment depth as determined by geotechnical engineer or local practice. Place and secure pole into the bucket using Polecrete® Stabilizer. Mix and place stabilizer according to manufacturer's recommendations.



156 Circle Freeway Dr.
Cincinnati, OH 45246
800-822-7437
www.MagnumPiering.com

Other Foundation Products



Other Foundation Products

System Ratings & Specifications



Foundation Products	Name	Fits Pile/Pier	Connection	Structural Capacity*	Description	Surface Coating**	Schematic
MCP312	Crawl Space Jack	N/A	(4) 1/8" x 1" Tabs	4 tons Ultimate, 2 tons Allowable in Compression	3.00" diameter x 1/8" wall painted structural steel tube with adjustable threaded cap and 12" diameter galvanized footing plate	P/G	
BWR413-88	Basement Wall Reinforcing Beam	N/A	(2) 1/2" Concrete Anchors / Expansion Bolts	To Be Determined by Design Engineer (Varies with Wall Height and Backfill Pressure)	88" Long W4x13 Beam w/ Base Plate	P	
BWR413-96					96" Long W4x13 Beam w/ Base Plate	P	
BWR413-120					120" Long W4x13 Beam w/ Base Plate	P	
BWR413-144					144" Long W4x13 Beam w/ Base Plate	P	



Other Foundation Products

System Ratings & Specifications

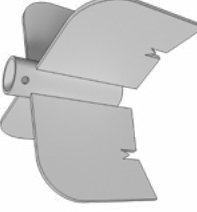

Foundation Products	Name	Fits Pile/Pier	Connection	Structural Capacity*	Description	Surface Coating**	Schematic
MFD325P2K14D	Sacrificial Full Displacement Tip	12-3/4" O.D.	Weld Per Design Engineer	N/A	3" x 0.25" wall x 18" stinger w/ 12-3/4" dia. x 1/2" Plate and 14D Helix to Fit 12-3/4" O.D. Pipe Casing	G, NG, EP	
MLOC1224-3	Shear Lock	MH313 & MH325	(1) 3/4" Set Screw	2 tons	12" Tall x 24" Wide Footprint	G, NG, EP	
MLOC1824-3				3 tons	18" Tall x 24" Wide Footprint		
MLOC2424-3				4 tons	24" Tall x 24" Wide Footprint		
MLOC1224-4		4.2 tons		12" Tall x 24" Wide Footprint	G, NG, EP		
MLOC1824-4		6.2 tons		18" Tall x 24" Wide Footprint			
MLOC2424-4		8.5 tons		24" Tall x 24" Wide Footprint			

Notes:

*Structural capacity is mechanical capacity of product under ideal conditions. Capacity of product may be limited by application, local ground conditions and service/deflection limits for a specific project. Final capacity should be determined by a registered design professional.

**NG = Bare Steel, G = Hot Dip Galvanized per ASTM A123/A153, P = MAGNUM® Blue Paint, EP = Epoxy Powder Coated

Most MAGNUM® helical pile products are manufactured using minimum 65 ksi minimum yield strength structural tubing and ASTM A36 plate steel, or better. As Magnum is committed to testing and improving products, these specifications are subject to change. Additional product specifications available at www.magnumpiling.com and from MAGNUM® technical support personnel upon request.

MAGNUM® MCP313

Crawl Space Support Post

Allowable Capacity 2 Tons

3.00" O.D. x 0.125" Wall High Strength Tube Post with Galvanized Footing Plate
 Adaptable to Crawl Spaces from 1 ft to 3.5 ft Tall

Description: The MAGNUM® MCP312 Crawl Space Support Post consists of a 3.00" O.D. by 0.125" thick wall tube with threaded adjustment and can support working loads up to 2 tons. The support post attaches to a 12.00" octagonal galvanized steel plate footing which when placed on 6" of gravel will support 2 tons on soils with IBC code minimum bearing pressure. The post has thin steel plate cap with bendable tabs for attachment to a new under floor steel drop beam. The post is designed in accordance with IBC, ACI, and AISC codes. Design and detailing of the floor joist support varies by project and is the responsibility of registered design professional including maximum joist span, support post spacing, and soil bearing capacity.

Specifications	
Post	3.00" Dia. x 0.13" Wall x 3.00' Tall ASTM A513 65 ksi or Better
Footing Plate	12.00" x 0.50" Octagonal Plate or 5.0" x 0.50" Square Plate
Beam	S4 x 7.7 Formed Steel Beam or Wood
Beam Connection	4.50" x 2.75" x 0.13" Steel Plate with Tabs or 3" x 3" x 1/4" Angle
Surface Coating	Galvanized per ASTM A153/A123 (G), Standard MAGNUM® Blue (P), or Epoxy Coated per ICC-ES AC228 (EP)

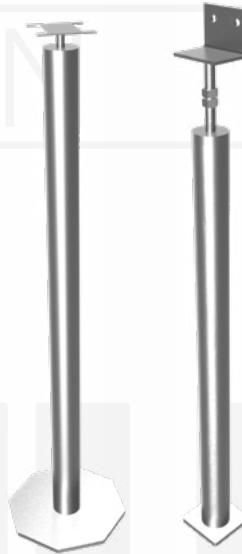

Installation Note: Layout required support post locations. Hand tamp required thickness of 0.75" angular gravel to provide support and good drainage for galvanized steel footings. Gravel should extend at least 6.00 inches beyond footing perimeter. Place footing plates. Measure and cut support post steel tube to fit crawl space height taking into account depth of new steel beam. Place beam over posts and tighten jack screws to seat beam firmly against floor joists. Bend tabs up to lock top of post to bottom flange of beam.



156 Circle Freeway Dr.
 Cincinnati, OH 45246
 800-822-7437
www.MagnumPiering.com

MAGNUM® BWR413

Basement Wall Reinforcing Beam

W4x13 – Available 88”, 96”, 100”, and 108” Tall with Base Plate
 Adaptable to Block and Cast-in-Place Basement Walls

Description: The MAGNUM® BWR413 Basement Wall Reinforcing Beam consists of a W4x13 steel beam with steel base plate for attachment to basement floor slabs. Top of the reinforcing beam is braced with MAGNUM® MP10008 or blocked, or otherwise fixed to the wood flooring system supported on the wall. Spacing and detailing of the reinforcing beams varies by project and is the responsibility of registered design professional including lateral earth pressures, support beam spacing, and connection to floor slab and floor framing system.

Specifications	
Beam	W4x13 ASTM A992
Lengths	88”, 96”, 100”, and 108” Standard (Custom Lengths Available)
Base Plate	4” x 6” Rectangular Plate with (2) Holes
Plate Connection	(2) ½” Expansion Anchors
Surface Coating	Standard MAGNUM® Paint (P)



Installation Note: Layout required reinforcing beam locations. Attach beams to footing or floor slab using (2) ½” expansion anchors. If attaching to footing, grout opening through slab after attachment of base plate. Attach top of beam to wood floor system above by cross bracing as required for shear force. Block wood floor system as required to transfer lateral loads. Grout between beam and wall if necessary for firm contact.



156 Circle Freeway Dr.
 Cincinnati, OH 45246
 800-822-7437
www.MagnumPiering.com

MAGNUM® MFD325P2K14D

Sacrificial Full Displacement Tip

3" x 0.25" Wall x 18" Stinger w/ 12-3/4"Ø x 1/2" Plate and 14D Helix to Fit 12-3/4" O.D. Pipe Casing

Description: The MAGNUM® MFD325P2K14D full displacement tips made to fit a 12-3/4" O.D. casing pipe (by others). Together the displacement tip and casing create a rotary driven pipe pile that is drilled into the ground to support structures. Design and detailing of the connection of pile to the structure varies by project and is the responsibility of the registered design professional including maximum concrete span, pile spacing, concrete shear, and concrete bearing.

Specifications	
Capacity	$P_a = 1.4 * T$
Soils	Applicable in Loose to Medium Dense Sands, Silts, Clays, and End Bearing on Rock
Pile Connection	Weld Per Design Engineer
Surface Coating	Galvanized per ASTM A153/A123 (G), Bare Steel (NG), or Epoxy Coated per ICC-ES AC228 (EP)
Compatibility	Fits 12-3/4" O.D. Pipe

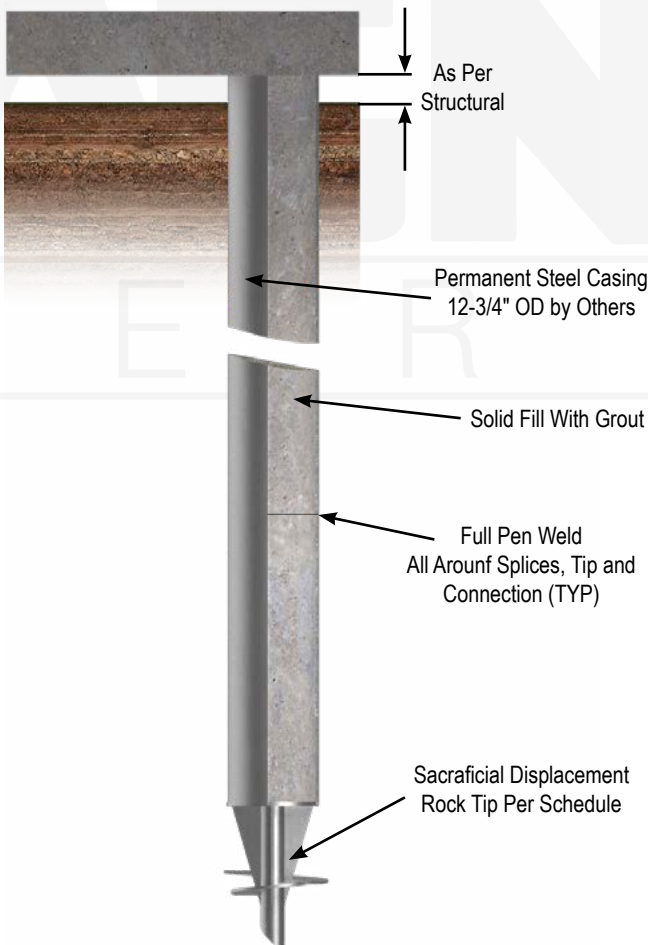

Installation Notes: Weld full displacement tip to casing before installation. Full displacement rotary driven pipe piles shall be installed using a multi-purpose drill or auger motor mounted to a large track mounted hydraulic machine. The drill shall have a minimum of 20 ton of crowd force. Connect the pile shaft to the drill head using a minimum of three 1-1/2" Ø drive pins. Position and align the pile at the location and to the inclination shown on the drawings and crowd the pilot point into the soil. Begin drilling to advance the lead section. If necessary, continue to add extension sections in order to achieve correct depth and torque. All sections shall be advanced into the soil in a smooth, continuous manner at a rate of rotation between 10 and 40 revolutions per minute. Constant axial force (crowd) shall be applied while rotating the pipe piles into the ground. The torsional strength rating of the pile casing shall not be exceeded during installation.

MAGNUM
P I E R I N G
designed to support

156 Circle Freeway Dr.
Cincinnati, OH 45246
800-822-7437
www.MagnumPiering.com

MAGNUM® MLOC##24-3 Shear Lock

Allowable Lateral Capacity 4 Tons

3/8" Plate and 3.13" I.D. Collar

Fits MH313B, MH313BR, MH325, MH325BR(-6)

Description: The MAGNUM® MLOC##24-3 shear lock has 4 tons allowable capacity in lateral load resistance at ground level. The shear lock consists of a collar tube with (1) 3/4" set screw for connection to MAGNUM® helical piles. The bracket is designed in accordance with ICC-ES document AC358 as well as IBC, and AISC codes. Design and detailing of the pile connection to the structure varies by project and is the responsibility of the registered design professional.

Specifications	
Collar Tube	0.25 in. x 3.13 in. I.D. ASTM A513 65 ksi or Better
Configuration	3/8" Plate
Pile Connection	(1) 3/4" SAE J429 Grade 8 Zinc Coated to ASTM B695/F1941
Surface Coating	Galvanized per ASTM A153/A123 (G), Bare Steel (NG), or Epoxy Coated per ICC-ES AC228 (EP)
Compatibility	MH313B, MH313BR, MH325B, MH325BR(-6)

Part Number Height, H	Allowable Capacity
MLOC1224-3 12"	2 Tons
MLOC1824-3 18"	3 Tons
MLOC2424-3 24"	4 Tons



Installation Notes: Install the helical pile to the correct depth and torque. Slide the Shear lock over the pile head and push into soil such that shear lock plates are completely embedded in surrounding soil. DO NOT excavate soil surrounding pile head to install shear lock. If soil is excavated use a flowable fill to backfill excavated soil around shear lock. Prepare the pile for pile cap as required.

MAGNUM®
P I E R I N G
designed to support

156 Circle Freeway Dr.
Cincinnati, OH 45246
800-822-7437
www.MagnumPiering.com

MAGNUM® MLOC##24-4 Shear Lock

Allowable Lateral Capacity 8.5 Tons

1/2" Plate and 4.63" I.D. Collar
Fits MH429(-6) & MH434(-6)

Description: The MAGNUM® MLOC##24-4 shear lock has 8.5 tons allowable capacity in lateral load resistance at ground level. The shear lock consists of a collar tube with (1) 3/4" set screw for connection to MAGNUM® helical piles. The bracket is designed in accordance with ICC-ES document AC358 as well as IBC, and AISC codes. Design and detailing of the pile connection to the structure varies by project and is the responsibility of the registered design professional.

Specifications	
Collar Tube	0.31 in. x 4.63 in. I.D. ASTM A513 65 ksi or Better
Configuration	1/2" Plate
Pile Connection	(1) 3/4" SAE J429 Grade 8 Zinc Coated to ASTM B695/F1941
Surface Coating	Galvanized per ASTM A153/A123 (G), Bare Steel (NG), or Epoxy Coated per ICC-ES AC228 (EP)
Compatibility	MH429(-6) & MH434(-6)

Part Number Height, H	Allowable Capacity
MLOC1224-4 12"	4.2 Tons
MLOC1824-4 18"	6.2 Tons
MLOC2424-4 24"	8.5 Tons

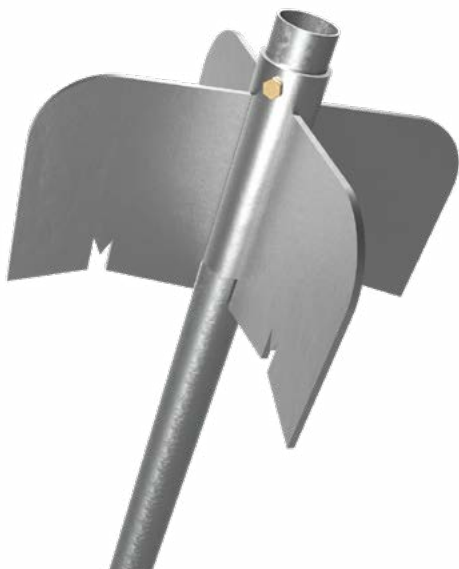
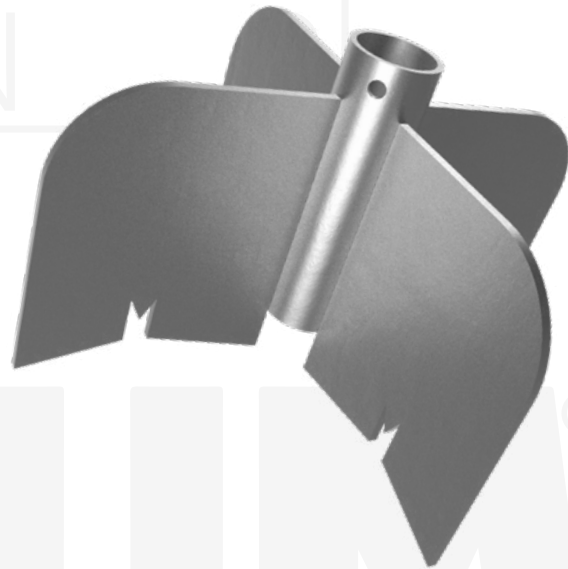

Installation Notes: Install the helical pile to the correct depth and torque. Slide the Shear lock over the pile head and push into soil such that shear lock plates are completely embedded in surrounding soil. DO NOT excavate soil surrounding pile head to install shear lock. If soil is excavated use a flowable fill to backfill excavated soil around shear lock. Prepare the pile for pile cap as required.

MAGNUM®
P I E R I N G
designed to support

156 Circle Freeway Dr.
Cincinnati, OH 45246
800-822-7437
www.MagnumPiering.com

MAGNUM® MLOC##24 Shear Lock

Allowable Lateral Capacity (lbs)*

MLOC1224										
Head Fixity	Helical Pile	Shaft Dia., d (in)	Non-Cohesive Soils				Cohesive Soils			
			V. Loose	Loose	Medium	Dense	V. Soft	Soft	Medium	Stiff
	MH325	3.00	600	1,350	1,900	2,650	550	1,450	3,150	4,000
	MH429	4.50	1,100	2,200	3,050	4,200	900	2,100	4,250	7,900
	MH434	4.50	1,150	2,350	3,250	4,500	900	2,200	4,400	8,200
	Minimum Pile Depth, h =		28d	28d	28d	34d	34d	34d	34d	34d
	MH325	3.00	2,100	3,700	4,000	4,000	1,350	3,300	4,000	4,000
	MH429	4.50	3,600	6,400	7,850	8,400	2,050	4,650	8,400	8,400
	MH434	4.50	3,750	7,600	8,400	8,400	2,100	4,800	8,400	8,400
	Minimum Pile Depth, h =		40d	40d	40d	40d	40d	40d	40d	40d

MLOC1824										
Head Fixity	Helical Pile	Shaft Dia., d (in)	Non-Cohesive Soils				Cohesive Soils			
			V. Loose	Loose	Medium	Dense	V. Soft	Soft	Medium	Stiff
	MH325	3.00	650	1,650	2,400	3,350	650	1,650	3,650	6,000
	MH429	4.50	1,150	2,600	3,600	5,050	1,000	2,350	4,800	9,050
	MH434	4.50	1,200	2,750	3,850	5,400	1,000	2,400	5,000	9,400
	Minimum Pile Depth, h =		28d	28d	28d	34d	34d	34d	34d	34d
	MH325	3.00	2,600	4,700	6,000	6,000	1,550	3,900	6,000	6,000
	MH429	4.50	4,250	7,700	9,500	11,700	2,350	5,400	10,100	12,400
	MH434	4.50	4,450	9,750	11,000	12,400	2,400	5,600	11,200	12,400
	Minimum Pile Depth, h =		40d	40d	40d	40d	40d	40d	40d	40d

MLOC2424										
Head Fixity	Helical Pile	Shaft Dia., d (in)	Non-Cohesive Soils				Cohesive Soils			
			V. Loose	Loose	Medium	Dense	V. Soft	Soft	Medium	Stiff
	MH325	3.00	700	1,950	2,900	4,150	700	1,850	4,100	8,000
	MH429	4.50	1,200	3,000	4,300	6,050	1,050	2,500	5,300	10,100
	MH434	4.50	1,250	3,150	4,550	6,400	1,050	2,600	5,500	10,400
	Minimum Pile Depth, h =		28d	28d	28d	34d	34d	34d	34d	34d
	MH325	3.00	3,200	6,000	7,700	8,000	1,800	4,500	8,000	8,000
	MH429	4.50	5,000	9,300	11,600	14,600	2,550	6,050	11,500	17,000
	MH434	4.50	5,200	10,600	13,200	16,800	2,600	6,200	12,700	17,000
	Minimum Pile Depth, h =		40d	40d	40d	40d	40d	40d	40d	40d

*Limitations: IBC2021 states that the allowable lateral capacity of a pile shall be half the load causing 1-inch of deflection. Many professionals use the lateral capacity at a deflection of 0.5 inches as the allowable lateral capacity. The allowable lateral capacities shown in these tables are based on a predicted deflection of 0.5 inches at the ground surface. Refer to MAGNUM® Technical Reference Manual for theoretical load displacement curves and for allowable capacities at other deflection limits. These capacity tables are based on lateral load applied at ground surface and galvanized shafts with 50 years corrosion in non-severe corrosive conditions. Contact MAGNUM® technical support professionals for lateral capacity when loads are applied above ground, for other corrosion conditions, or for resistance to bending moments. Occasionally, annular space can develop around upper portions of the shaft when helical piles have multiple bolted couplings (all MAGNUM® helical piles larger than 3.5" diameter) or when installation methods cause excessive wobbling. It is recommended that any annular space be grouted from the surface using fast-setting, non-shrink, neat cement grout when lateral capacity is required.



Helical Solar Pile Product Number Specification Legend

Example

The MAGNUM® Helical Solar Pile product number below **MHS413P10K12D14DG** is for a pile with 4.5" diameter shaft, a 0.13" wall thickness, an integral plate cap, 10 ft. long with (2) 0.375" Dual Cutting Edge Helices, 12 and 14 inches in diameter, and the surface preparation is Galvanized.

Note: See "Magnum Piering Helical Solar Pile Specifications" table on next page for detailed information. Specification information is also available at www.magnumpiering.com

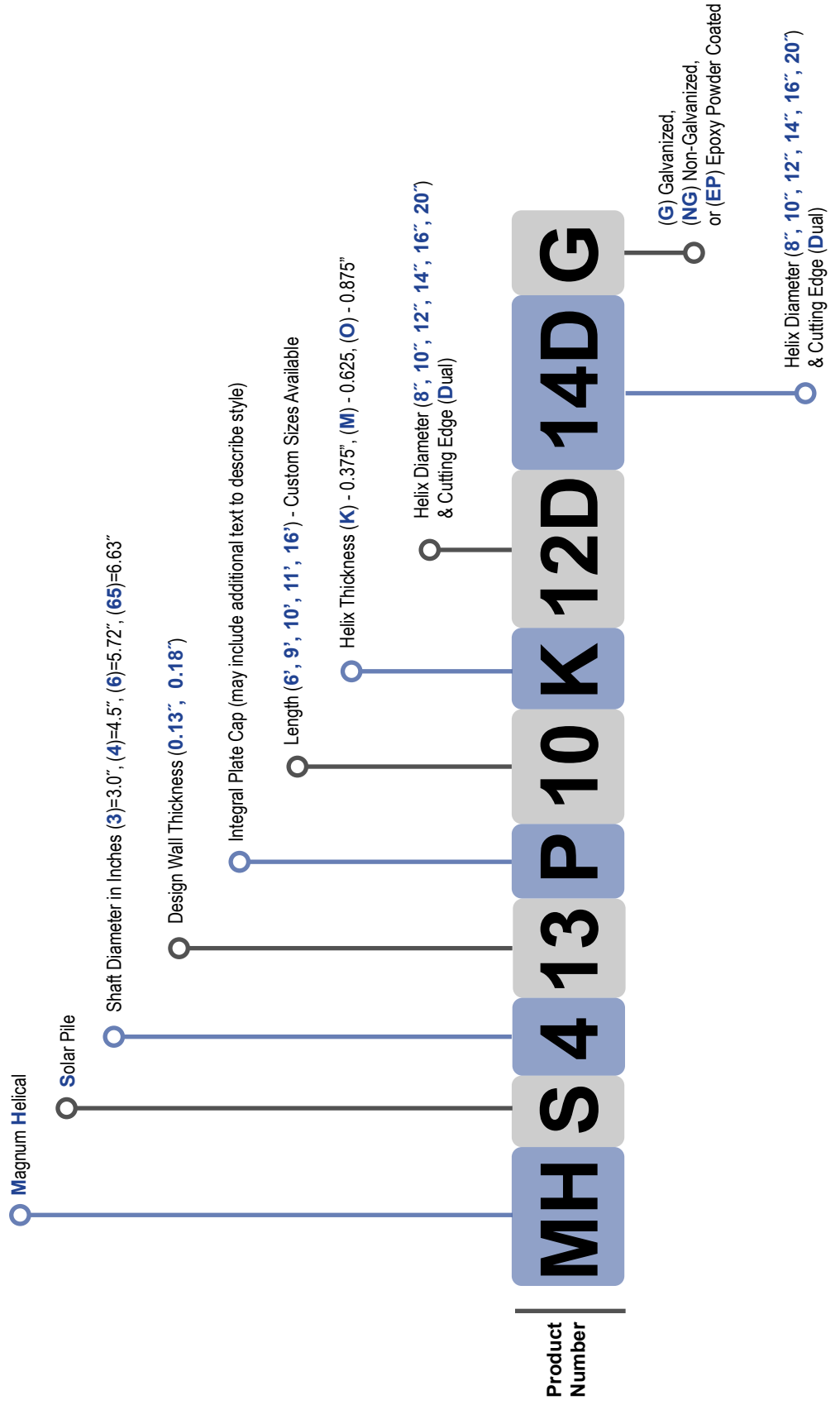

Helical Solar Piles

System Ratings & Specifications



Solar Pile Products	Shaft Specifications			Maximum Installation Torque (ft-lbs)	Capacity to Torque Ratio (ft ⁻¹)	Maximum Capacity (Tension & Comp)		Lateral Capacity (lbs)		Helix Sizes (dual cutting edge) (in)	Helix Gauge	Surface Coating**	Standard Lengths (custom sizes available) (ft)	Schematic
	Design Wall Gauge (in)	Outside Diameter (in)	Approx Weight (plf)			Ultimate (tons)	Allowable (tons)	@ 18" a.g.s.	@ 60" a.g.s.					
MHS313	0.125	3.00	4.0	6,000	8.0	24	12	1600	550	8, 10, 12, 14	0.375	G, NG, EP	6, 8	
MHS3521	0.21	3.50	7.9	12,000	7.0	42	21	3000	1300	8, 10, 12, 14	0.375	G, NG, EP	6, 8	
MHS413	0.125	4.50	6.0	14,000	5.7	40	20	3300	1400	10, 12, 14	0.375	G, NG, EP	6, 8, 10	
MHS419	0.188	4.50	9.1	21,000	5.7	60	30	4500	1850	10, 12, 14, 16	0.375	G, NG, EP	6, 8, 10	
MHS425	0.25	4.50	12.0	28,000	5.7	80	40	5200	2300	10, 12, 14, 16	0.375	G, NG, EP	6, 8, 10	
MHS613	0.125	5.72	7.7	23,000	4.6	53	26	5000	2250	12, 16	0.375	G, NG, EP	8, 11, 16	
MHS619	0.188	5.72	11.5	34,000	4.6	78	39	6800	3100	12, 16, 20	0.375	G, NG, EP	8, 11, 16	
MHS6513	0.125	6.63	8.9	25,000	4.0	50	25	6200	3200	12, 16, 20	0.375	G, NG, EP	8, 11, 16	
MHS6519	0.188	6.63	13.3	35,000	4.0	70	35	7500	4000	12, 16, 20	0.375	G, NG, EP	8, 11, 16	

Notes: *Lateral capacity is approximate and based on stiff clay (SPT N>10) or better soils with deep embedment (flexible pile design). Theoretical deflection is limited to 3" or less at the pile head. Lateral load is applied at distance shown above ground surface (a.g.s.). Contact Magnum's technical support and engineering team for site specific solar pile designs.

**G = Hot-Dip Zinc Galvanized per ASTM A123/A153, NG = Bare Steel, EP = Epoxy Powder Coated per ICC-ES AC228, P = MAGNUM® Blue Paint

Most MAGNUM® helical pile products are manufactured using minimum 65 ksi minimum yield strength structural tubing, or better, for the shaft and ASTM A36 plate steel, or better, for the helical bearing plates. As Magnum is committed to testing and improving products, these specifications are subject to change. Additional product specifications available at www.magnumpiling.com and in the MAGNUM® Helical Pile Engineering Reference Manual available upon request. Structural capacity is for piles in firm soil with fully braced pile cap. Structural capacity takes into account corrosion over IBC design life in moderate to high corrosive soils based on ICC-ES AC358. Consult a MAGNUM® corrosion engineer for severely corrosive soils.

MAGNUM® Helical Bollards

Description: MAGNUM® Helical Bollards consist of a steel shaft and helical bearing plate and are easy to install around your site to direct vehicle traffic and protect important features and equipment. MAGNUM® products are manufactured in the USA according to our ISO 9001 approved Quality Program. MAGNUM® Helical Bollards are available in either 4.5 inch, or 6 inch diameter and various lengths. After installation the Helical Bollard can be covered with a durable HDPE cover available in many colors and designs to match your site's color scheme.

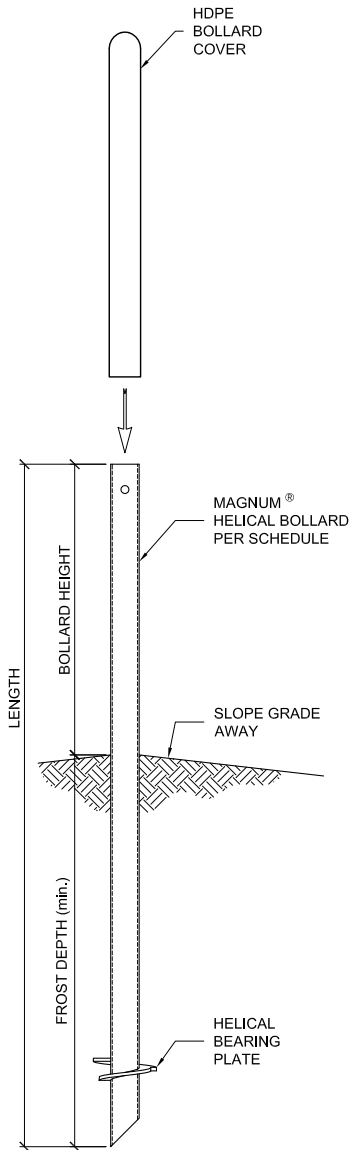

HELICAL BOLLARD SCHEDULE			
PRODUCT NUMBER	O.D. (in)	MAXIMUM INSTALLATION TORQUE (ft*lb)	SUGGESTED BOLLARD COVER LENGTH (in)
MBL04	4.5	10,000	52
MBL06	5.72	18,000	52

Push Pier Rams & Accessories



MAGNUM® MP6000K Ram Kit

31 Ton Maximum Capacity

3.25" Bore, 22" Stroke, 7,500 psi Maximum Pressure Hydraulic Ram Assembly for MP313 and MP325 Push Pier Shafts

Description: MAGNUM® MP6000K Push Pier Rams are used for installation and load testing Magnum MP313 and MP325 push piers. The ram has an ultimate capacity of 31 tons at maximum pressure. It is used for repair, lifting, and permanent support of existing foundations. Ram height with channels is 82.5". The assembly can accommodate push pier columns up to 36" long that are coupled together by male-female slip connections. Additional push pier column sections can be added until the pier reaches adequate bearing material and a successful load test is achieved. Ram shoe fits various Magnum foundation brackets. Permanent pier to bracket connection is made with up to three (3) 3/4" Grade 8 bolts.



Specifications	
Bore	3.25" Dia.
Piston Rod	2.0" Dia.
Stroke	22"
Max. Pressure	7,500 psi
Burst Pressure	15,000 psi
Bolts	(1) 3/4"
Nose Adapter	2.5" Dia. (Fits MP313 & MP325 Shafts)
Hydraulic Hose	3/8" Dia.

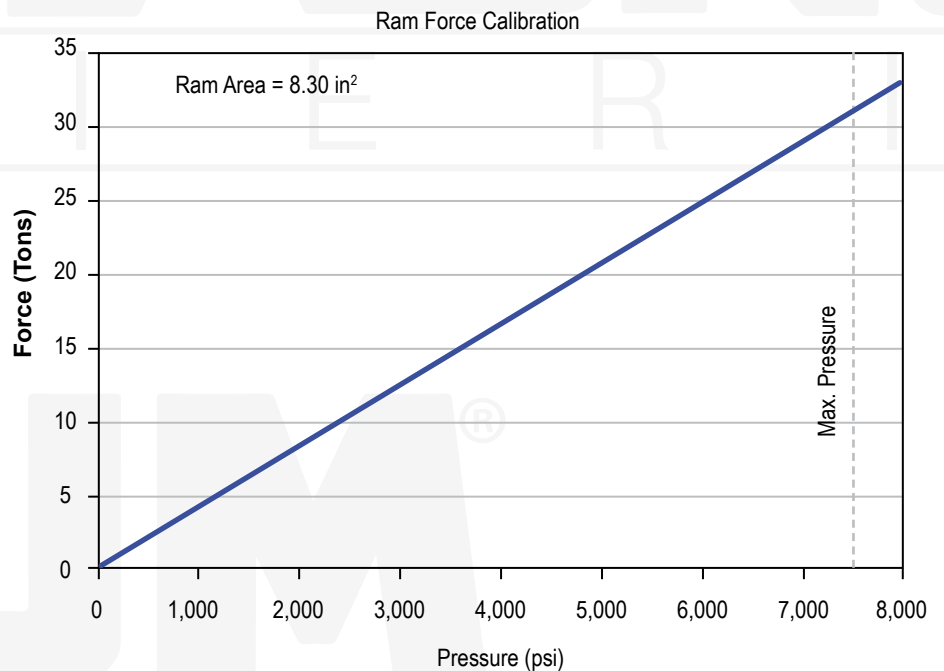

Note: MAGNUM®'s push piercing system is used for stabilization and lifting. Bracket connection to structure, required pier capacity, and pier spacing should be designed by a professional engineer taking into account the thickness, weight, live loads, and punching shear strength of the existing foundation.

MAGNUM®
P I E R I N G
designed to support

156 Circle Freeway Dr.
Cincinnati, OH 45246
800-822-7437
www.MagnumPiering.com

MAGNUM® MP6005K Ram Kit

31 Ton Maximum Capacity

3.25" Bore, 12" Stroke, 7,500 psi Maximum Pressure Hydraulic Ram Assembly for MP313 and MP325 Push Pier Shafts

Description: MAGNUM® MP6005K Push Pier Rams are used for installation and load testing Magnum MP313 and MP325 push piers. The ram has an ultimate capacity of 31 tons at maximum pressure. It is used for repair, lifting, and permanent support of existing foundations. Ram height with channels is 52-7/8". The assembly can accommodate push pier columns up to 18" long that are coupled together by male-female slip connections. An additional push pier column sections can be added until the pier reaches adequate bearing material and a successful load test is achieved. Ram shoe fits various Magnum foundation brackets. Permanent pier to bracket connection is made with up to three (3) 3/4" Grade 8 bolts.

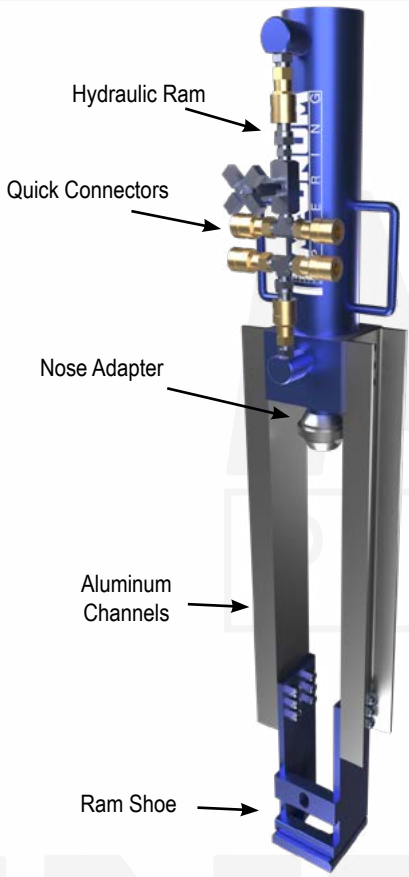

Specifications	
Bore	3.25" Dia.
Piston Rod	2.0" Dia.
Stroke	12"
Max. Pressure	7,500 psi
Burst Pressure	15,000 psi
Bolts	(1) 3/4"
Nose Adapter	2.5" Dia. (Fits MP313 & MP325 Shafts)
Hydraulic Hose	3/8" Dia.

Ram Force Calibration

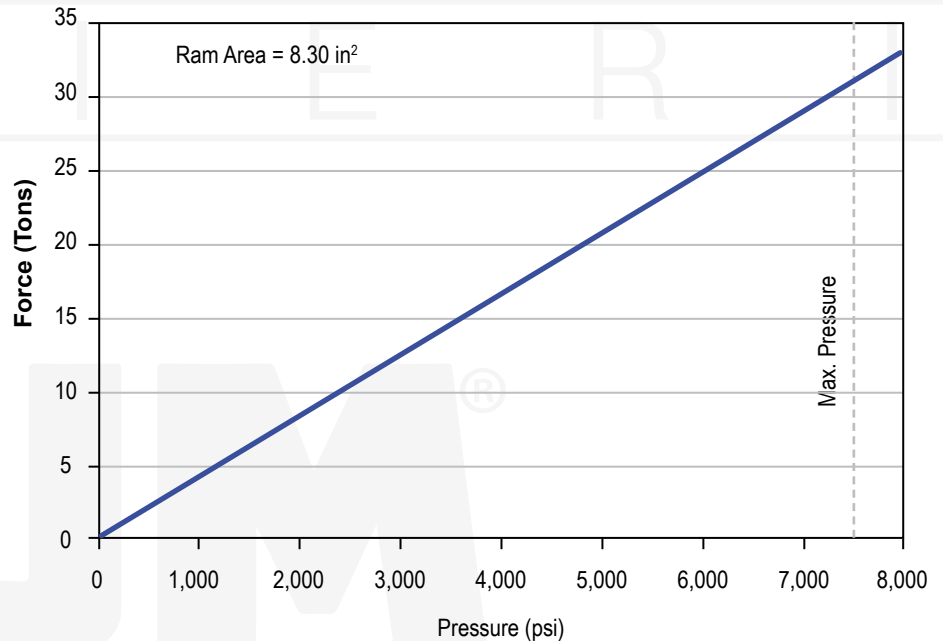

Note: MAGNUM®'s push piercing system is used for stabilization and lifting. Bracket connection to structure, required pier capacity, and pier spacing should be designed by a professional engineer taking into account the thickness, weight, live loads, and punching shear strength of the existing foundation.



156 Circle Freeway Dr.
Cincinnati, OH 45246
800-822-7437
www.MagnumPiering.com

MAGNUM® MP6012K Ram Kit

12 Ton Maximum Capacity

2.00" Bore, 22" Stroke, 7,500 psi Maximum Pressure Hydraulic Ram Assembly for MP212 Push Pier Shaft

Description: MAGNUM® MP6012K Push Pier Rams are used for installation and load testing Magnum MP212 push piers. The ram has an ultimate capacity of 12 tons at maximum pressure. It is used for repair, lifting, and permanent support of existing foundations. Ram height with channels is 76-9/16". The assembly can accommodate push pier columns up to 36" long that are coupled together by male-female slip connections. Additional push pier column sections can be added until the pier reaches adequate bearing material and a successful load test is achieved. Ram shoe fits various Magnum foundation brackets. Permanent pier to bracket connection is made with up to three (3) 3/4" Grade 8 bolts.



Specifications	
Bore	2.00" Dia.
Piston Rod	1.25" Dia
Stroke	22"
Max. Pressure	7,500 psi
Burst Pressure	15,000 psi
Bolts	(1) 3/4"
Nose Adapter	1.75" Dia. (Fits MP212 Push Pier Shaft)
Hydraulic Hose	3/8" Dia.

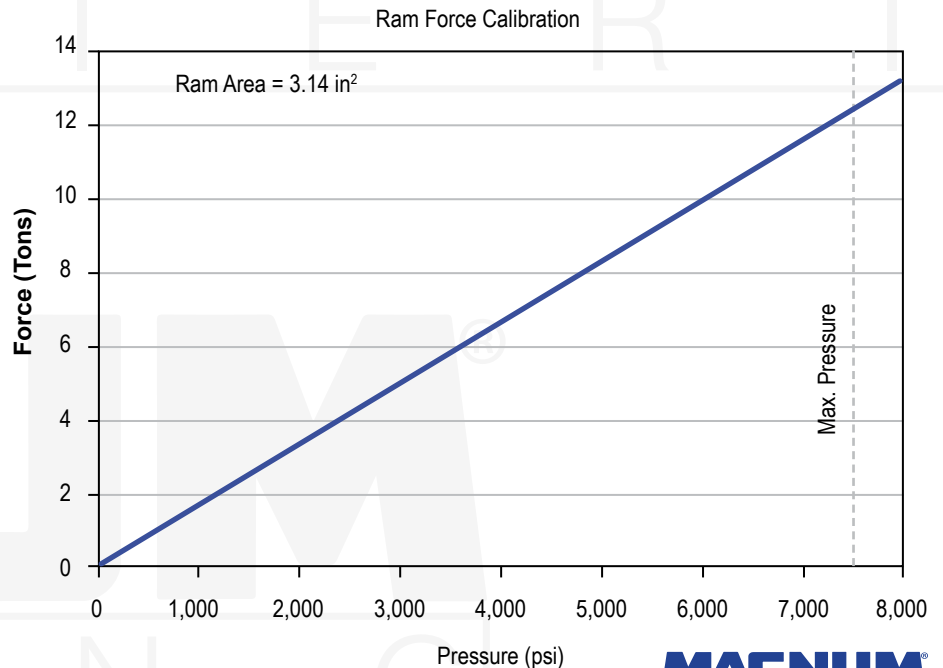

Note: MAGNUM®'s push piercing system is used for stabilization and lifting. Bracket connection to structure, required pier capacity, and pier spacing should be designed by a professional engineer taking into account the thickness, weight, live loads, and punching shear strength of the existing foundation.

MAGNUM®
P I E R I N G
designed to support

156 Circle Freeway Dr.
Cincinnati, OH 45246
800-822-7437
www.MagnumPiering.com

MAGNUM® MP6013K Ram Kit

12 Ton Maximum Capacity

2.00" Bore, 12" Stroke, 7,500 psi Maximum Pressure Hydraulic Ram Assembly for MP212 Push Pier Shaft

Description: MAGNUM® MP6013K Push Pier Rams are used for installation and load testing Magnum MP212 push piers. The ram has an ultimate capacity of 12 tons at maximum pressure. It is used for repair, lifting, and permanent support of existing foundations. Ram height with channels is 52-7/8 inches. The assembly can accommodate push pier columns up to 18" long that are coupled together by male-female slip connections. Additional push pier column sections can be added until the pier reaches adequate bearing material and a successful load test is achieved. Ram shoe fits various Magnum foundation brackets. Permanent pier to bracket connection is made with up to three (3) 3/4" Grade 8 bolts.



Specifications	
Bore	2.00" Dia.
Piston Rod	1.25" Dia
Stroke	12"
Max. Pressure	7,500 psi
Burst Pressure	15,000 psi
Bolts	(1) 3/4"
Nose Adapter	1.75" Dia. (Fits MP212 Push Pier Shaft)
Hydraulic Hose	3/8" Dia.

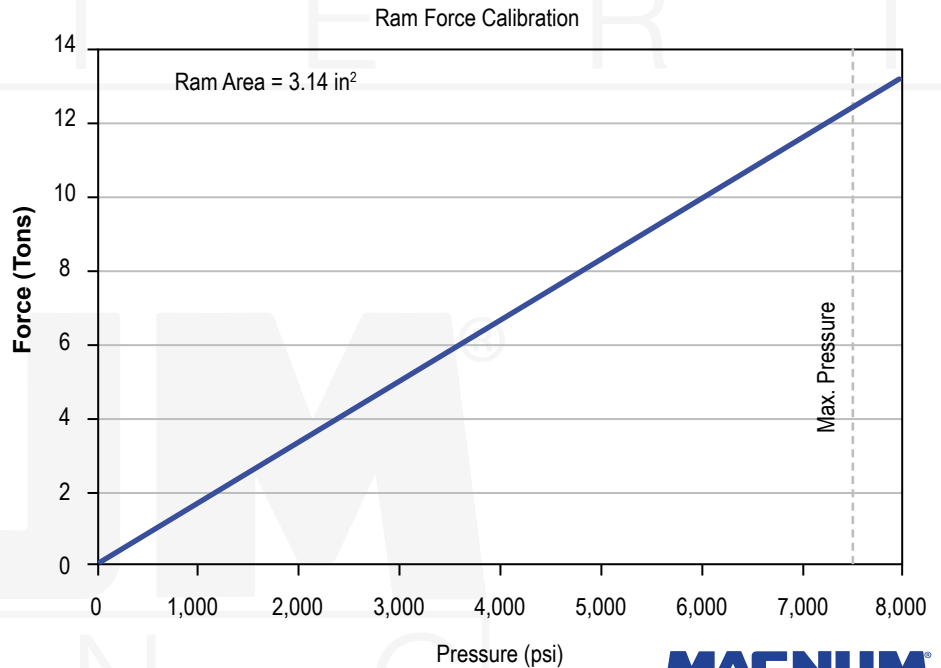

Note: MAGNUM®'s push piercing system is used for stabilization and lifting. Bracket connection to structure, required pier capacity, and pier spacing should be designed by a professional engineer taking into account the thickness, weight, live loads, and punching shear strength of the existing foundation.



156 Circle Freeway Dr.
Cincinnati, OH 45246
800-822-7437
www.MagnumPiering.com

MAGNUM® MP6015K Slabjack Ram Kit

8 Ton Maximum Capacity

2.00" Bore, 20" Stroke, 5,000 psi Maximum Pressure Hydraulic Ram Assembly for MP212 Slabjack Pier Shaft

Description: MAGNUM® MP6015 Slabjack Rams are used for lifting and temporary support of slabs-on-grade and other light structures. The ram has an ultimate lifting capacity of 8 tons at maximum pressure. It is used for precision lifting applications in combination with grout injection for longer term support. Ram and stand height is 66.16". The assembly can accommodate push pier columns up to 36" long that are coupled together by male-female slip connections. Additional push pier column sections can be added until the pier reaches adequate bearing material and a successful load test is achieved. Base plate consists of two 6" x 12" rectangles with (10) bolt hole pattern. Pier to slab connection, if needed, is by non-shrink grout.

Specifications

Specifications	
Bore	2.00" Dia.
Piston Rod	1.25" Dia.
Stroke	22"
Max. Pressure	7,500 psi
Burst Pressure	15,000 psi
Bolts	(10) .5" x 4.5" Titen HD or Equiv.
Nose Adapter	1.75" Dia. (Fits MP212 Push Pier Shaft)
Hydraulic Hose	3/8" Dia.

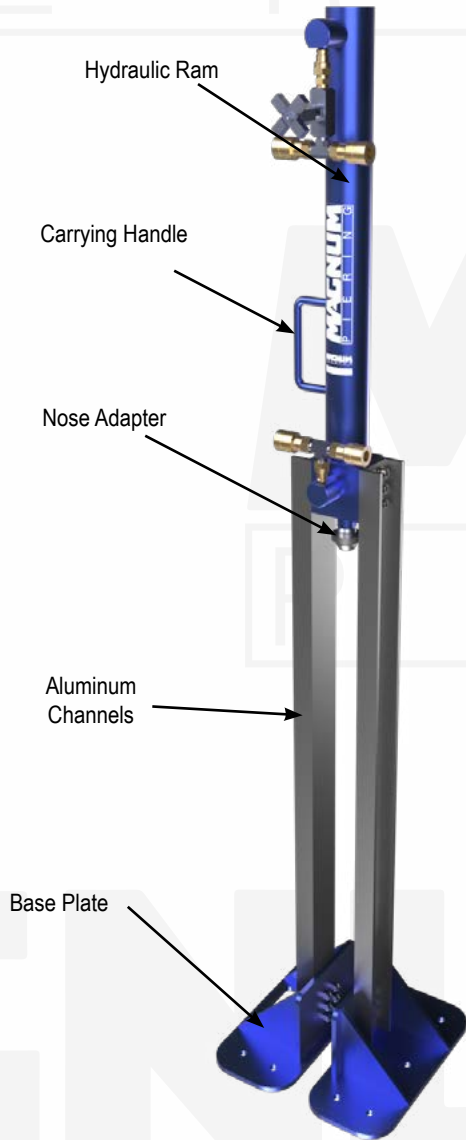

Ram Force Calibration

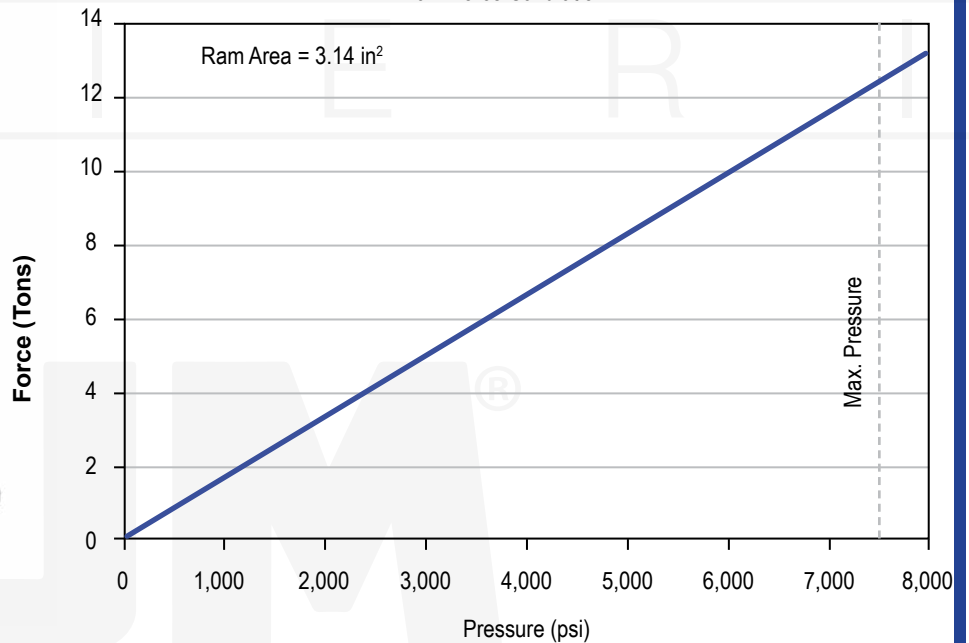

Note: MAGNUM®'s slabjack piercing system is rated for temporary lifting only. Permanent slab support, pier to slab connection, required pier capacity, and pier spacing should be designed by a professional engineer taking into account the thickness, weight, live loads, and punching shear strength of the slab.



156 Circle Freeway Dr.
Cincinnati, OH 45246
800-822-7437
www.MagnumPiering.com

Tooling



MAGNUM® Magnetic Drill Hole Templates/Jigs

Description: After installation of MAGNUM® Helical Pile to correct depth, torque, elevation and capacity, shop installed holes may not be usable due to final elevations. To aid with field installing new connection holes, Magnum offers Magnetic Drill Hole Templates for each of the helical pile product lines. See table below for part numbers, descriptions, compatibility & bolt patterns included on the drill jig. If your product line is not listed below, please contact the Magnum sales department for the correct part number.



Installation Notes: If maximum torque is obtained prior to final elevation or pile installation is stopped for any reason, including installer choice, then final pile head elevation shall be obtained by cutting-off the top of the shaft. Place Magnum bolt hole and cut-off template over each pile shaft and adjust to template to desired elevation. Cut-off piles with portable band saw. Using MAGNUM® drilling template to ensure correct bolt hole locations, drill holes through cut-off pile shaft for steel plate caps with a magnetic drill press and appropriate size drill bit (bolt diameter + 1/16"). Magnum suggest annular cutting drill bits with cutting oil to be used to field install new bolt holes. It is also important to use a variable speed magnetic drill and set drill to the correct speed to prolong drill bit life.



MAGNUM® Torque Motor Adapter Order Form

Date: _____

Customer Info: _____

Company Name: _____ Contact Name: _____

Phone: _____ Fax: _____

Cell Phone: _____ Email Address: _____

Shipping Address: Street: _____

City: _____ State: _____ Zip _____

Installation Equipment Details:

Installation Motor Make/Model: _____ In-Line Torque Measurement Device Make/Model: _____

Output Shaft: _____ In-Line Torque Measurement Device Make/Model: _____

MAGNUM® Product(s) Used on Project: _____

Adapter Measurements (If Info Above Not available):

Torque Motor

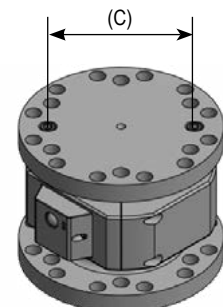
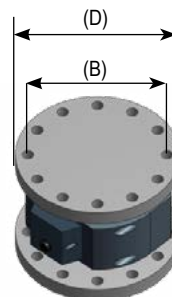
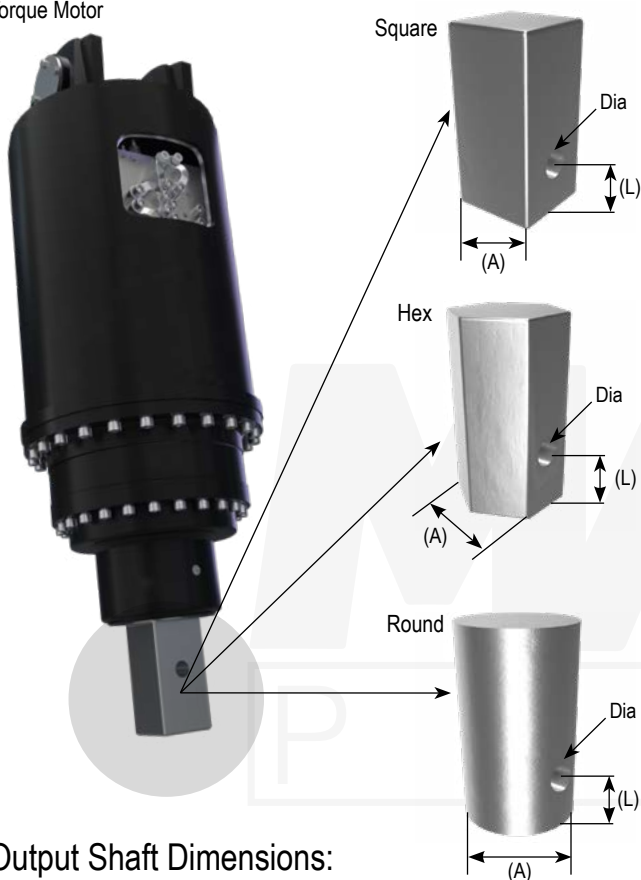

In Line Torque Measurement:

Output Plate Dimension: (D) _____

Bolt Hole Center Dimension: (B) _____ MM IN.

Bolt Hole Diameter: _____

Quantity of Bolt Holes: _____

Secondary Bolt Hole Center Diameter: (C) _____

Secondary Bolt Hole Diameter: _____

Secondary Quantity of Bolt Holes: _____

Output Shaft Dimensions:

Shape: _____

Dimensions: (A) _____

Hole Placement: (L) _____

Dimension Hole Diameter: _____



MAGNUM® Torque Motor Adapter Order Form (continued)

Customer Requirements:



Direct Connect Adapter^{1,2,3}
Adapter from output shaft direct to helical pile shaft.



Flanged Upper Adapter^{2,3}
Adapter from output shaft to in-line torque monitor or to flanged lower adapter.

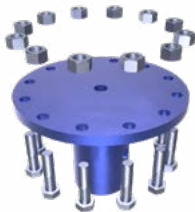

Flanged lower Adapter^{1,2}
Adapter from in-line torque monitor or flanged upper to helical shaft.

Notes:

1. Comes w/ (1) set of installation pins
2. Comes complete w/ (1) set of connection hardware to in-line measurement device
3. Pin from motor to adapter NOT included.

Liability Form:

Disclaimer – MAGNUM® Piering does not include installation adapters, tooling, or equipment with material orders. Purchasers/Contractors/Installers are responsible to place orders for installation adapters or tooling from MAGNUM® Piering and are to notify MAGNUM® what installation equipment they are using so the appropriate adapters can be supplied. Purchasers are required to provide the details noted on this adapter order form to ensure the correct adapter is ordered. MAGNUM® Piering is not responsible for any connection issues, alignment issues, pile damage if adapters supplied by “others” are used for installation or due to incorrect information provided on this form.

Customer Name: _____

Magnum Material Order/ Project Name: _____

Signature: _____

Date ____/____/____

MAGNUM® MHA4010-2

Foot Operated Hydraulic Control

3,500 psi Maximum Pressure

Control Assembly for Torque Motors

Description: The MAGNUM® MHA4010-2 is a foot operated hydraulic control for operation of a variety of torque motors. The device enables hands free operation and has applications for foundation repair and augmentation using helical piles. It is beneficial in the operation of torque motors inside existing structures using an external hydraulic power pack and portable torque motors without heavy equipment. The pedal is bidirectional for control of forward and reverse rotation. Twin hydraulic gauges measure input pressure and back pressure for determination of motor torque.

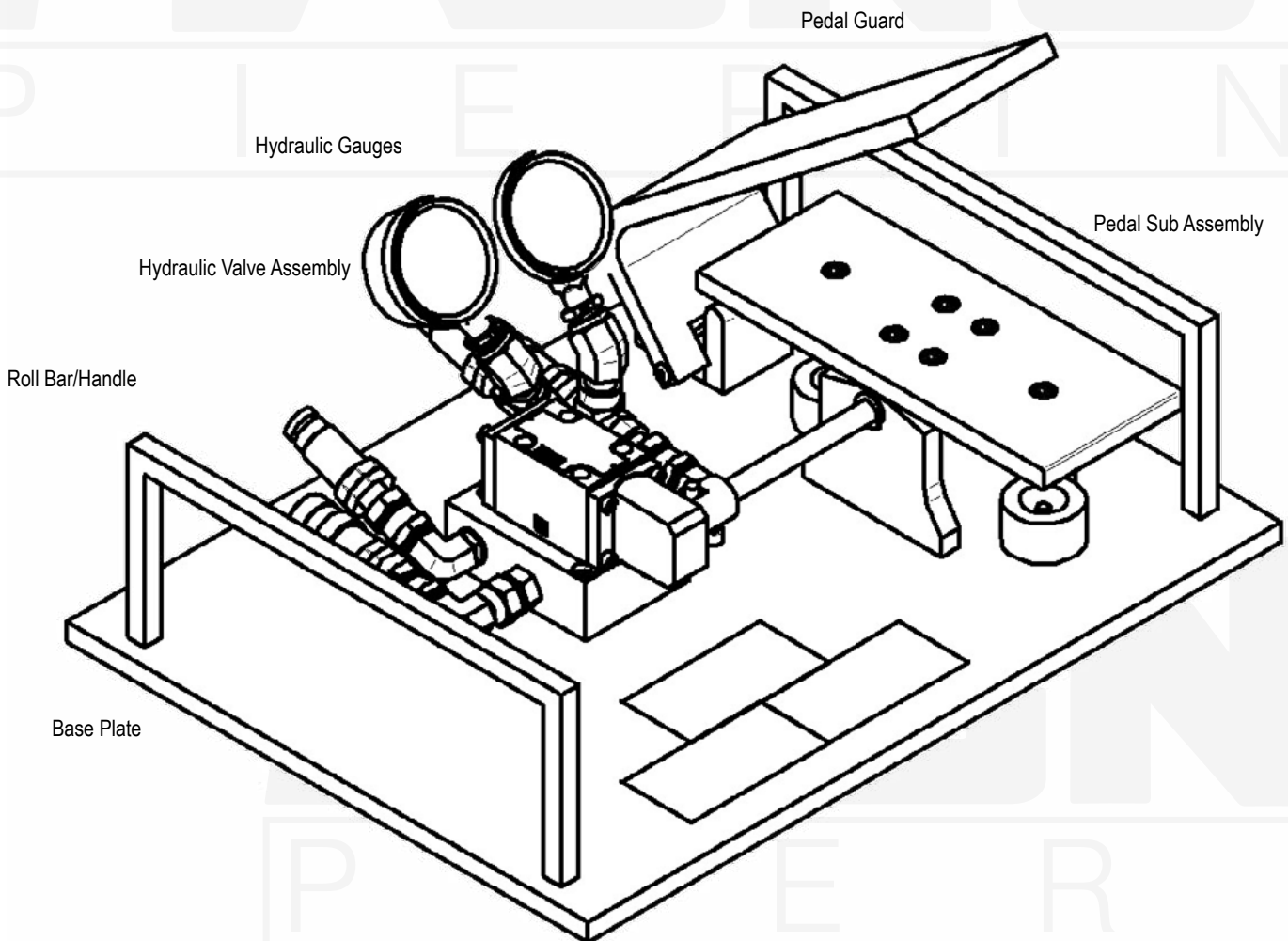

Note: Torque motors have differing hydraulic pressure and flow requirements. Consult a MAGNUM® technical support representative for assistance in determining compatibility of the MHA4010-2 with specific torque motors.

MAGNUM® MHA4130

Torque Motor Skid

Storage and Transport Skid for Torque Motors with 2-1/2" or 2" Hex Kelly bar

Description: The MAGNUM® MHA4130 is a storage and transport skid that accommodates a variety of torque motors having a 2-1/2" or 2" hex kelly bar. The skid creates a secure transportation and storage location for your torque motor, allowing for easy reattachment to equipment. The convenient tie down holes and lifting pockets make loading and unloading your torque motor easier, while avoiding costly damage to your torque motor during transport.

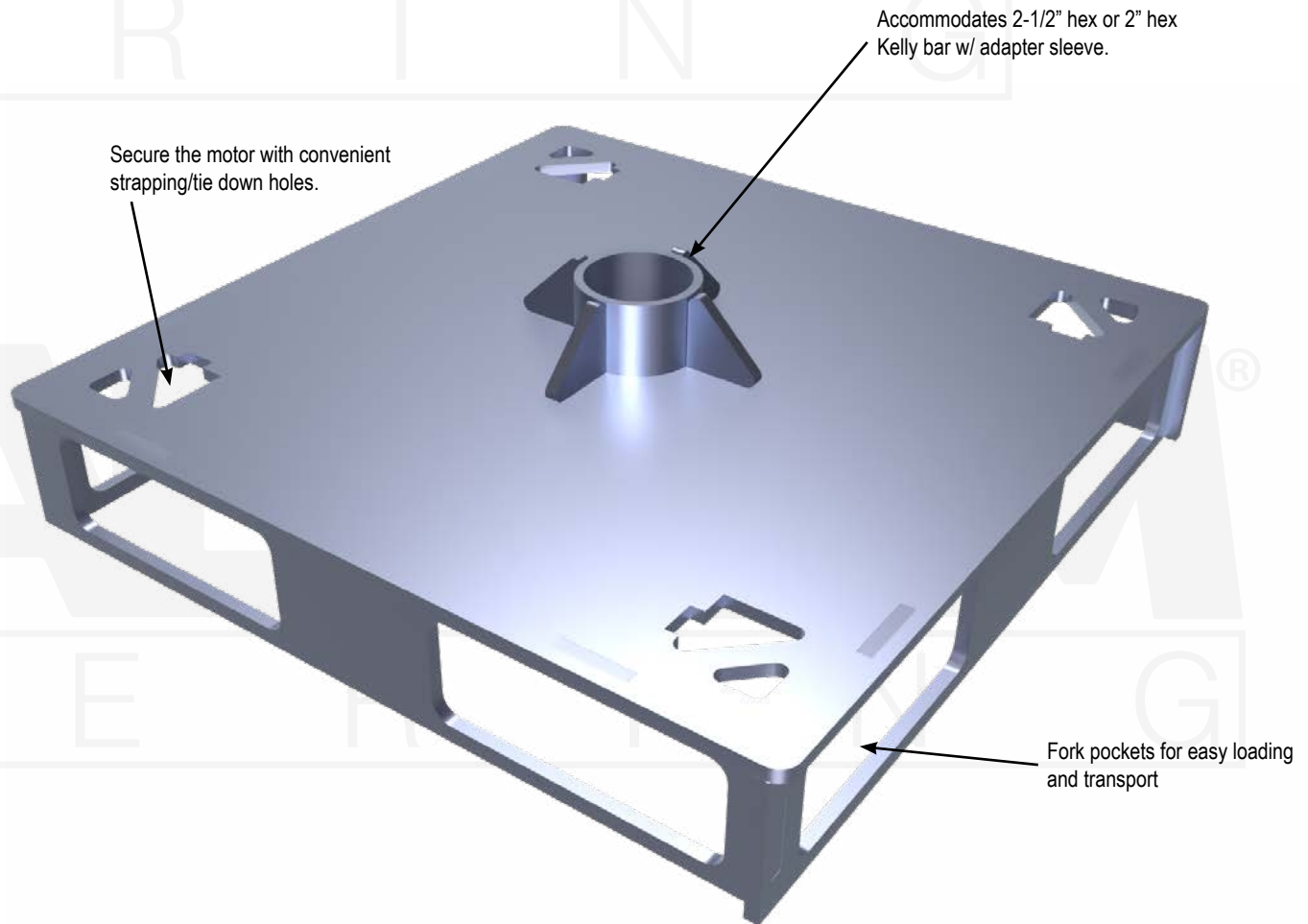

Note: Consult a MAGNUM® Sales Representative if interested in a torque motor skid for your torque motor.

Micropile & Thread Bar Brackets



Micropile Bracket Specifications

System Ratings & Specifications

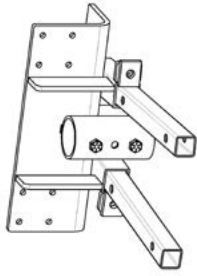
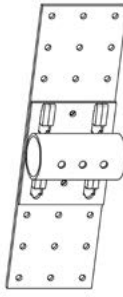
Micropile Brackets	Name	Fits Pile Dia. (in)	No. Bolts / Thru Holes	Bolt Hole Dia. (in)	Structural Capacity*		Description	Surface Coating**	Schematic
					Ultimate (tons) Comp / Tens	Allowable (tons) Comp / Tens			
MP1009-30	Micropile Angle Bracket	3.00	3	3/4	50 / 22	25 / 11	8" x 6" x 21" Gusseted Angle w/ 8 bolt holes	G, P	
MP1009-35	Micropile Angle Bracket	3.50	3	3/4	50 / 22	25 / 11	8" x 6" x 21" Gusseted Angle w/ 8 bolt holes	G, P	
MP1009-40	Micropile Angle Bracket	4.00	3	3/4	50 / 22	25 / 11	8" x 6" x 21" Gusseted Angle w/ 8 bolt holes	G, P	
MP1009-45	Micropile Angle Bracket	4.50	3	3/4	50 / 22	25 / 11	8" x 6" x 21" Gusseted Angle w/ 8 bolt holes	G, P	
MP1018-30	Micropile Plate Bracket	3.00	3	3/4	50 / 50	25 / 25	8" x 27" x 3/8" Plate w/ 18 bolt holes	G, P	
MP1018-35	Micropile Plate Bracket	3.50	3	3/4	50 / 50	25 / 25	8" x 27" x 3/8" Plate w/ 18 bolt holes	G, P	
MP1018-40	Micropile Plate Bracket	4.00	3	3/4	50 / 50	25 / 25	8" x 27" x 3/8" Plate w/ 18 bolt holes	G, P	
MP1018-45	Micropile Plate Bracket	4.50	3	3/4	50 / 50	25 / 25	8" x 27" x 3/8" Plate w/ 18 bolt holes	G, P	

Notes:

*Most MAGNUM® products are manufactured using minimum ASTM A513, with 65 ksi minimum yield strength structural tubing, or better, for the collar and ASTM A36 plate steel, or better, for the bearing plates. As MAGNUM® is committed to testing and improving products, these specifications are subject to change. Additional product specifications may be available at www.magnumpiling.com from Magnum's technical support professionals upon request. Structural capacity of bracket and micropile system may be limited by the capacity of the micropile and the structure to which the bracket is connected. Capacity of the micropile and structure shall be determined by an engineer.

***G = Hot Dip Zinc galvanized per ASTM A153/A123 as appropriate, P = MAGNUM® Blue Paint

MAGNUM® MP1009 Micropile Bracket

Allowable Capacity 26 Tons



8" x 6" x 21" x 3/8" Angle with (8) 9/16" Anchor Holes
 Fits 3", 3.5", 4" & 4.5" O.D. Steel Micropile Casings

Specifications	
Collar Tube	0.37 in. x 3", 3.5", 4" or 4.5" I.D. ASTM a513, Fy = 65 ksi or better
Configuration	8"x6"x21"x3/8" Angle w/ (8) 9/16" Anchor Holes
Pile Connection	(1, 2 or 3) 3/4" SAE J429 Grade 8 Zinc Coated to ASTM B695/F1941
Surface Coating	Galvanized per ASTM A153/A123 (G) or Standard MAGNUM® Blue Paint (P) or Epoxy Coated per ICC-ES AC228 (EP)
Compatibility	3", 3.5", 4" or 4.5" O.D. Steel Micropile Casings

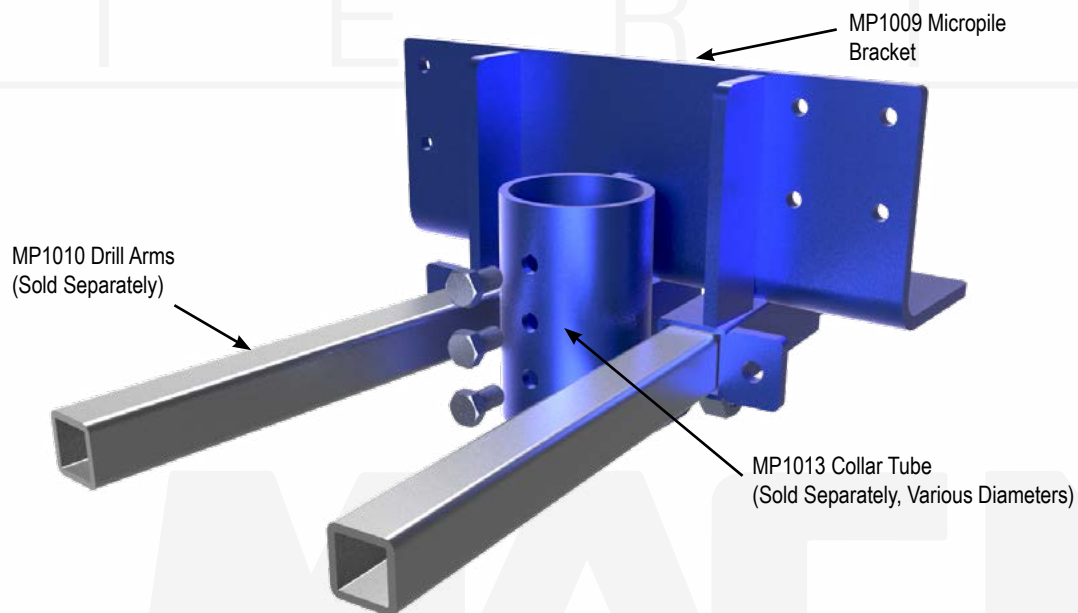
Description: MAGNUM® Micropile Bracket consists of a hinged collar tube with (3) 3/4" threaded bolt holes for connection to micropile casing and a steel angle with thru holes for attachment to existing concrete using expansion anchors. The bracket also has integrated motor mount support points to easily align micropile placement. MAGNUM® products are manufactured in the USA according to our ISO 9001 approved quality program. MAGNUM® brackets are designed in accordance with ICC-AC358, IBC, ACI, and AISC codes. Design and detailing of the connection to the structure varies by project and is the responsibility of the registered design professional including maximum concrete span, pier spacing, concrete shear, and concrete bearing.



Installation Notes: Apply a grout bed of high strength, fast setting, non-shrink grout at a minimum of 1/2" thick to the bottom angle face, then attach the bracket. After grout sets, attach drill support arms and mount drill. Drill micropile to the specified depth. Install desired reinforcing steel bar, grout and a 6ft minimum length section of casing at the top of the pile. Slip appropriate collar tube over the micropile casing and secure to bracket with (1) 1-1/4" bolt. Remove the drill and drill arms for use on the next micropile. Once the micropile grout has cured a MAGNUM® ram or MAGNUM® lifting kit, with the appropriate sized shoe, can be used to life and re-level the structure if necessary. Lock-off the pile to the bracket with one, two or three 3/4" Grade 8 bolts, or weld. (Expansion Anchors Sold Separately)

Connection Type	Ultimate Capacity* 0.13 / 0.25 Wall Casing	Allowable Capacity* 0.13 / 0.25 Wall Casing
 Single Bolted	10 Tons / 18 Tons	5 Tons / 9 Tons
 Double Bolted	17 Tons / 35 Tons	8 Tons / 18 Tons
 Triple Bolted	28 Tons / 50 Tons	14 Tons / 25 Tons

*Bracket connection to pile consists of field threaded blind bolts as described in Section 7-13 of AISC Code. Capacities shown are based on IAS accredited laboratory testing of MAGNUM® products.



156 Circle Freeway Dr.
 Cincinnati, OH 45246
 800-822-7437
www.MagnumPiering.com

MAGNUM® MP1018 Micropile Bracket

Allowable Capacity 26 Tons

8" x 27" x 3/8" Plate with (18) 9/16" Anchor Holes

Fits 3", 3.5", 4" & 4.5" O.D. Steel Micropile Casings

Specifications	
Collar Tube	0.37 in. x 3", 3.5", 4" or 4.5" I.D. ASTM a513, Fy = 65 ksi or better
Configuration	8"x27"x3/8" Plate w/ (18) 9/16" Anchor Holes
Pile Connection	(1, 2 or 3) 3/4" SAE J429 Grade 8 Zinc Coated to ASTM B695/F1941
Surface Coating	Galvanized per ASTM A153/A123 (G) or Standard MAGNUM® Blue Paint (P) or Epoxy Coated per ICC-ES AC228 (EP)
Compatibility	3", 3.5", 4" or 4.5" O.D. Steel Micropile Casings

Description: MAGNUM® Micropile Bracket consists of a steel plate with tabbed connection to a collar tube and (3) 3/4" threaded bolt holes for connection to micropile casing. The steel plate can be attached to existing concrete using expansion anchors. A steel motor mount support can be attached to the bracket easily align micropile placement. MAGNUM® products are manufactured in the USA according to our ISO 9001 approved quality program. MAGNUM® brackets are designed in accordance with ICC-AC358, IBC, ACI, and AISC codes. Design and detailing of the connection to the structure varies by project and is the responsibility of the registered design professional including maximum concrete span, pier spacing, concrete shear, and concrete bearing.

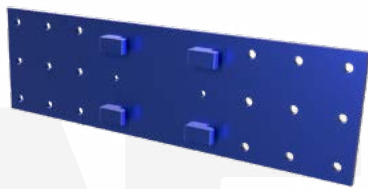

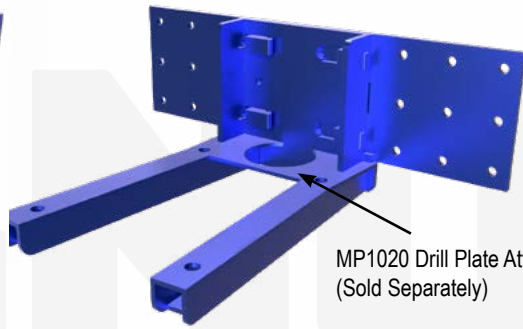

MP1018 Micropile Plate Bracket

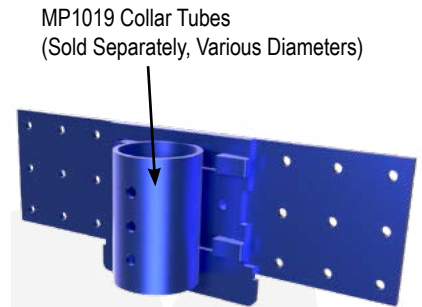

MP1020 Drill Plate Attachment (Sold Separately)



MP1019 Collar Tubes (Sold Separately, Various Diameters)

Connection Type	Ultimate Capacity* 0.13 / 0.25 Wall Casing	Allowable Capacity* 0.13 / 0.25 Wall Casing
 Single Bolted	10 Tons / 18 Tons	5 Tons / 9 Tons
 Double Bolted	17 Tons / 35 Tons	8 Tons / 18 Tons
 Triple Bolted	28 Tons / 50 Tons	14 Tons / 25 Tons

Installation Notes: Attach bracket plate to the side of existing foundation using up to (18) 1/2" concrete anchors. Attach drill support arms and mount drill. Drill micropile to the specified depth. Install desired reinforcing steel bar, grout and a 6ft minimum length section of casing at the top of the pile. Remove the drill and drill arms for use on the next micropile. Slip appropriate collar tube over the micropile casing and interlock tabbed connection, secure collar to plate with provided bolts. Once the micropile grout has cured a MAGNUM® ram or MAGNUM® lifting kit, with the appropriate sized shoe, can be used to lift and re-level the structure if necessary. Lock-off the pile to the bracket with one, two or three 3/4" Grade 8 bolts, or weld. To lock-off the pile, drill 11/16" diameter hole in pile shaft through threaded hole(s) in bracket collar. Install bolt(s) and use impact wrench to force bolt through pile shaft wall. (Expansion Anchors Sold Separately)

*Bracket connection to pile consists of field threaded blind bolts as described in Section 7-13 of AISC Code. Capacities shown are based on IAS accredited laboratory testing of MAGNUM® products.



156 Circle Freeway Dr.
Cincinnati, OH 45246
800-822-7437
www.MagnumPiering.com

MAGNUM® MP1029 Grout-Guide Micropile Bracket

Allowable Capacity 39 Tons

8" x 12" x 24" x 3/8" Angle with (12) 11/16" Anchor Holes

Fits 5.5", 6.0", 6.63", 7.0", 7.63" & 8.635" O.D. Steel Micropile Casings

Specifications	
Grout Guide	12.75" Dia. X 0.13" Wall (or better) x 36" Long
Configuration	8"x12"x24"x1/2" Angle w/ (12) 11/16" Anchor Holes
Pile Connection	Fill Annular Space with High-Strength, Non-Shrink Grout
Surface Coating	Galvanized per ASTM A153/A123 (G) or Standard MAGNUM® Blue Paint (P) or Epoxy Coated per ICC-ES AC228 (EP)
Compatibility	5.5", 6.0", 6.63", 7.0", 7.63" & 8.635" O.D. Steel Micropile Casings

Description: MAGNUM® Grout-Guide Micropile Bracket consists of a steel angle and a large diameter collar tube for grouted connection to micropile casing. The steel angle can be attached to existing concrete using expansion anchors. MAGNUM® products are manufactured in the USA according to our ISO 9001 approved quality program. MAGNUM® brackets are designed in accordance with ICC-AC358, IBC, ACI, and AISC codes. Design and detailing of the connection to the structure varies by project and is the responsibility of the registered design professional including maximum concrete span, pier spacing, concrete shear, and concrete bearing.

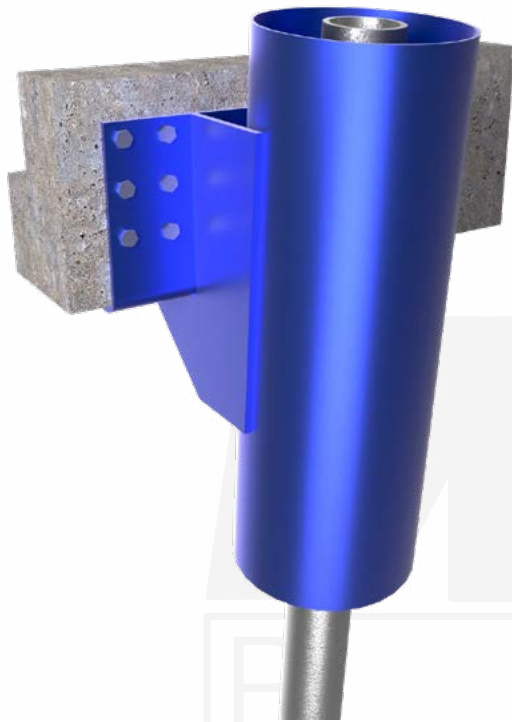

Micropile Casing			Allowable Capacity (Compression), Tons*
Diameter, in	Min. Thickness, in	Yield Strength, ksi	
5.5	0.415	80	27
5.5	0.562	80	35
6.625	0.432	80	39
7.0	0.408	80	39
7.625	0.43	80	39
8.625	0.5	80	39

*Based on combined bending/buckling in firm soil at a specified eccentricity of 7" from face of wall to centerline of micropile casing.

Installation Notes: Excavate soil in area of bracket. Notch footing (if any) flush with foundation wall. Apply a grout bed of high strength, fast setting, non-shrink grout a minimum of 1/2" thick to the bottom angle face, then attach the bracket to the foundation with a minimum of (6) 5/8" concrete anchors. After grout sets, drill micropile through the center of the guide sleeve. Install desired reinforcing steel bar, grout and a 6 ft minimum length section of casing at the top of the micropile. Fill annular space between guide sleeve and micropile casing with high-strength, non-shrink grout. (Expansion Anchors Sold Separately)



156 Circle Freeway Dr.
Cincinnati, OH 45246
800-822-7437
www.MagnumPiering.com

All-Thread Bar Product Number Specification Legend

Example

The MAGNUM® All-Thread Bar Accessory product number below **MTB075-06L24LHG** is for a grade 75, all-thread bar with nominal diameter of 3/4". The bar is 24" long with left-hand thread. The surface preparation is Galvanized.

Note: See "MAGNUM® All-Thread Bar Accessory Specifications" table on next page for detailed information. Specification information is also available at www.magnumpiercing.com

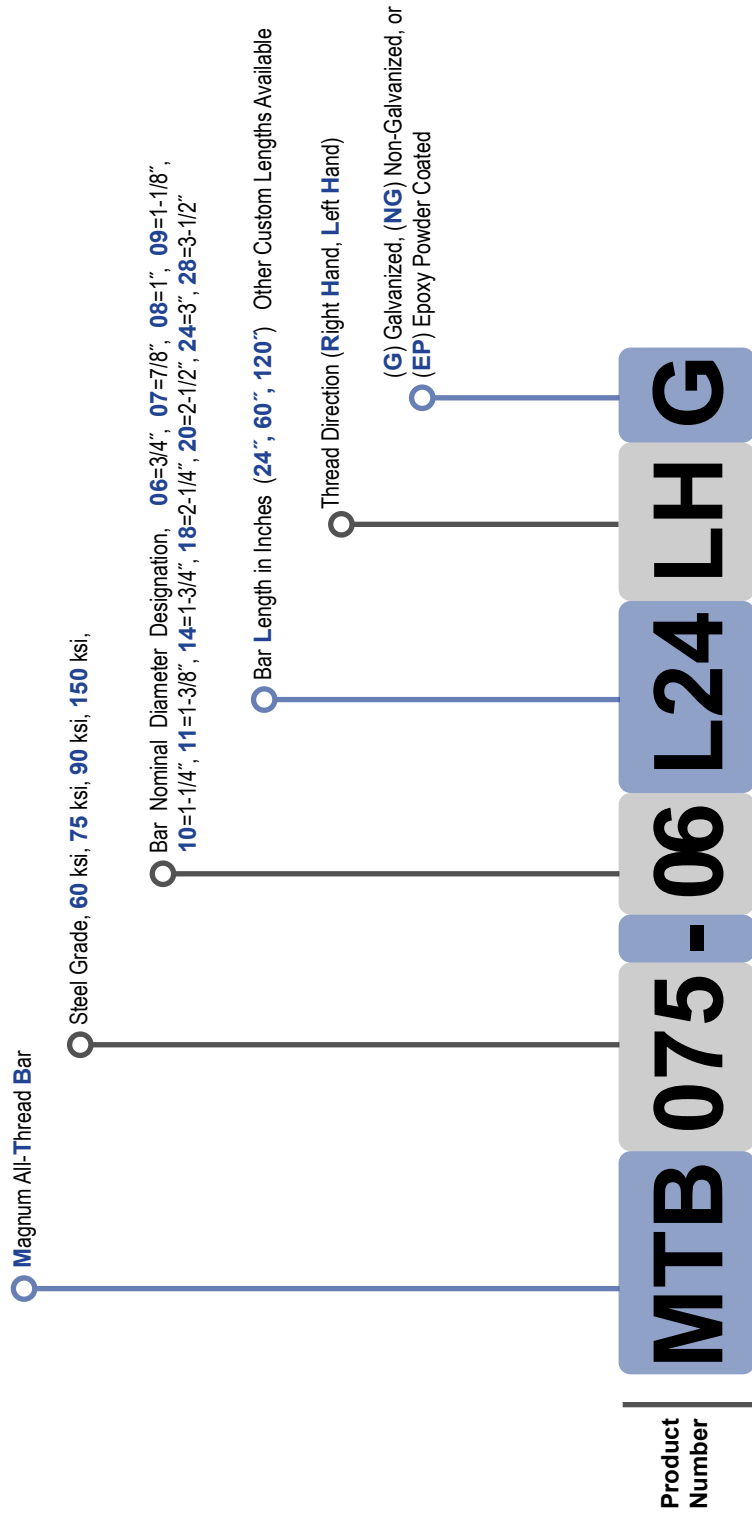

MAGNUM® MTB075 Grade 75 All-Thread Bar

22 ton to 480 ton Ultimate Capacity

75 ksi Yield, 100 ksi Ultimate Strength Continuous Threaded Bar

Description: Grade 75 All-Thread bars have an ultimate capacity from 22 to 480 tons in tension and compression (fully braced conditions only). All-Thread bars can be used in a variety of applications including micropiles, rock anchors, soil nails, and soil anchors for permanent and temporary structures. All thread bars are typically installed in ground using a fixed or articulated mast microdrill with down-hole or top vibratory hammer. These systems can have advantages over helical piles and push piers in soils with excessive rock, cobble, or debris. They also are useful when penetration into hard to very hard bedrock is required. Ultimate and yield strength shown in specifications below is indicative of the steel structural strength without corrosion. The strength of micropiles, rock anchors, soil nails, and soil anchors in ground may be limited by the soil-grout bond or grout-steel bond. MAGNUM® recommends that all thread bar applications be designed by a licensed professional engineer or architect experienced in the design of these systems. MAGNUM® technical support representatives are available to assist with design of grouted thread bar systems for a multitude of applications.

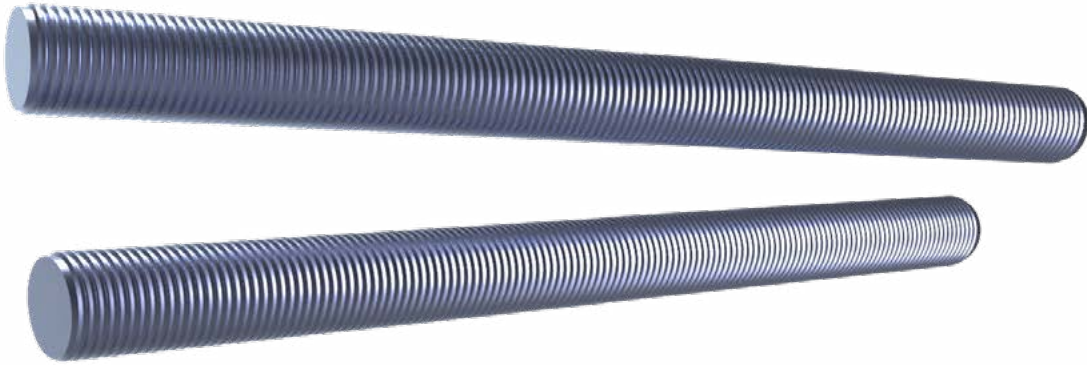

Specifications

Designation	Nominal Diameter	Gross Area (in ²)	Ultimate Strength (tons)	Yield Strength (tons)	Nominal Weight (plf)	Part Number
06	3/4"	0.44	22	17	1.5	MTB075-06LH
07	7/8"	0.602	30	23	2.0	MTB075-07LH
08	1"	0.79	40	30	2.7	MTB075-08LH
09	1-1/8"	1.00	50	38	3.4	MTB075-09LH
10	1-1/4"	1.27	64	48	4.3	MTB075-10LH
11	1-3/8"	1.56	78	59	5.3	MTB075-11LH
14	1-3/4"	2.25	113	84	7.7	MTB075-14RH
18	2-1/4"	4.00	200	150	13.6	MTB075-18RH
20	2-1/2"	4.91	246	184	16.7	MTB075-20RH
28	3-1/2"	9.61	480	360	32.7	MTB075-28RH

All-Thread Bar Accessory Product Number Specification Legend

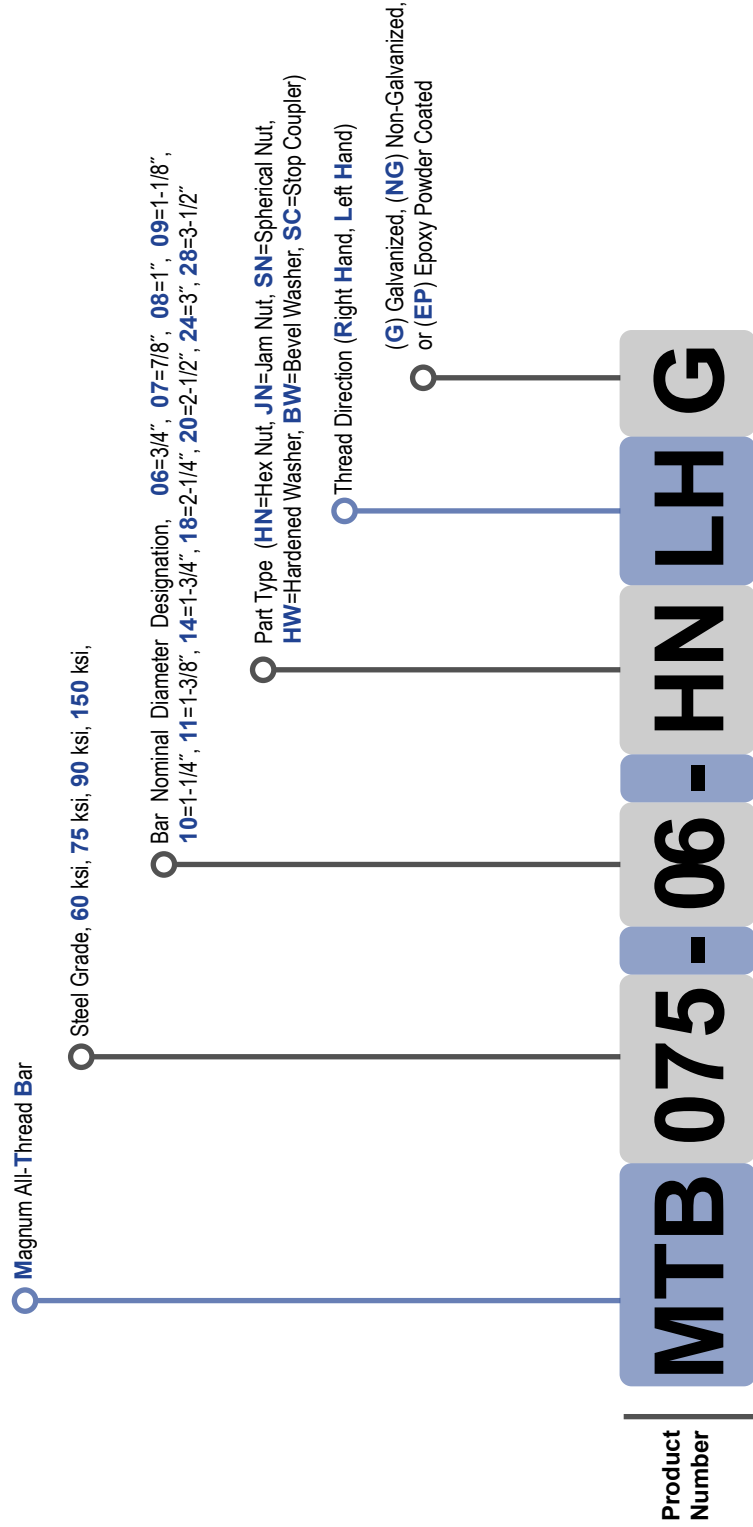

Example

The MAGNUM® All-Thread Bar Accessory product number below **MTB075-06-HN LH G** is for a grade 75, hex nut that fits an all-thread bar with nominal diameter of 3/4". The nut has left-hand thread. The surface preparation is Galvanized.



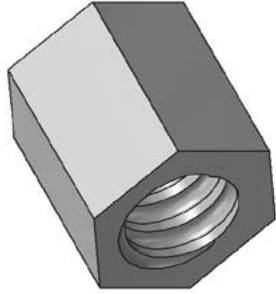
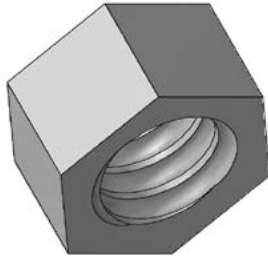

Thread Bar Accessories

System Ratings & Specifications

Accessories	Description	Notes	Surface Coating**	Schematic
MTB075-06HNLH	#6 Gr. 75 Hex Nut	Hex nuts are typically sold with MHC1080 Caps. Nuts shown here are for surplus or replacement parts.	G, NG, EP	
MTB075-08HNLH	#8 Gr. 75 Hex Nut		G, NG, EP	
MTB075-10HNLH	#10 Gr. 75 Hex Nut		G, NG, EP	
MTB075-14HNRH	#14 Gr. 75 Hex Nut		G, NG, EP	
MTB075-20HNRH	#20 Gr. 75 Hex Nut		G, NG, EP	
MTB075-06JNLH	#6 Gr. 75 Jam Nut	Hex nuts are typically sold with MHC1080 Caps. Nuts shown here are for surplus or replacement parts.	G, NG, EP	
MTB075-08JNLH	#8 Gr. 75 Jam Nut		G, NG, EP	
MTB075-10JNLH	#10 Gr. 75 Jam Nut		G, NG, EP	
MTB075-14JNRH	#14 Gr. 75 Jam Nut		G, NG, EP	
MTB075-20JNRH	#20 Gr. 75 Jam Nut		G, NG, EP	
MTB075-06ENLH	#6 Eye Nut	Hex nuts are typically sold with MHC1080 Caps. Nuts shown here are for surplus or replacement parts.	G, NG, EP	
MTB075-08ENLH	#8 Eye Nut		G, NG, EP	
MTB075-10ENLH	#10 Eye Nut		G, NG, EP	
MTB075-20ENRH	#20 Eye Nut		G, NG, EP	

Thread Bar Accessories

System Ratings & Specifications

Accessories	Description	Notes	Surface Coating**	Schematic
MTB075-06HW	#6 Hardened Washer	Wedge washers, if required, are sold separately. Wedge washers are available in 5, 10, and 15 deg angles depending on thread bar sizes.	G, NG	
MTB075-08HW	#8 Hardened Washer		G, NG	
MTB075-10HW	#10 Hardened Washer		G, NG	
MTB075-14HW	#14 Hardened Washer		G, NG	
MTB075-20HW	#20 Hardened Washer		G, NG	
MTB075-10BW	#10 15 Deg Bevel Washer	Wedge washers, if required, are sold separately. Wedge washers are available in 5, 10, and 15 deg angles depending on thread bar sizes.	G, NG	
MTB075-14BW	#14 5 Deg Bevel Washer		G, NG	
MTB075-20BW	#20 10 Deg Bevel Washer		G, NG	

Notes:

*G = Hot Dip Zinc Galvanized per ASTM A 153/A 153M or ASTM B 633 as appropriate, NG = bare steel, EP = Epoxy Powder Coated per ICC-ES AC228, P = MAGNUM® Blue Paint

As MAGNUM® is committed to testing and improving products, these specifications are subject to change. Additional product specifications available at www.magnumpiering.com, in the MAGNUM® Product Catalog, and in the MAGNUM® Helical Pile Engineering Manual available upon request.

Earth Anchor Systems

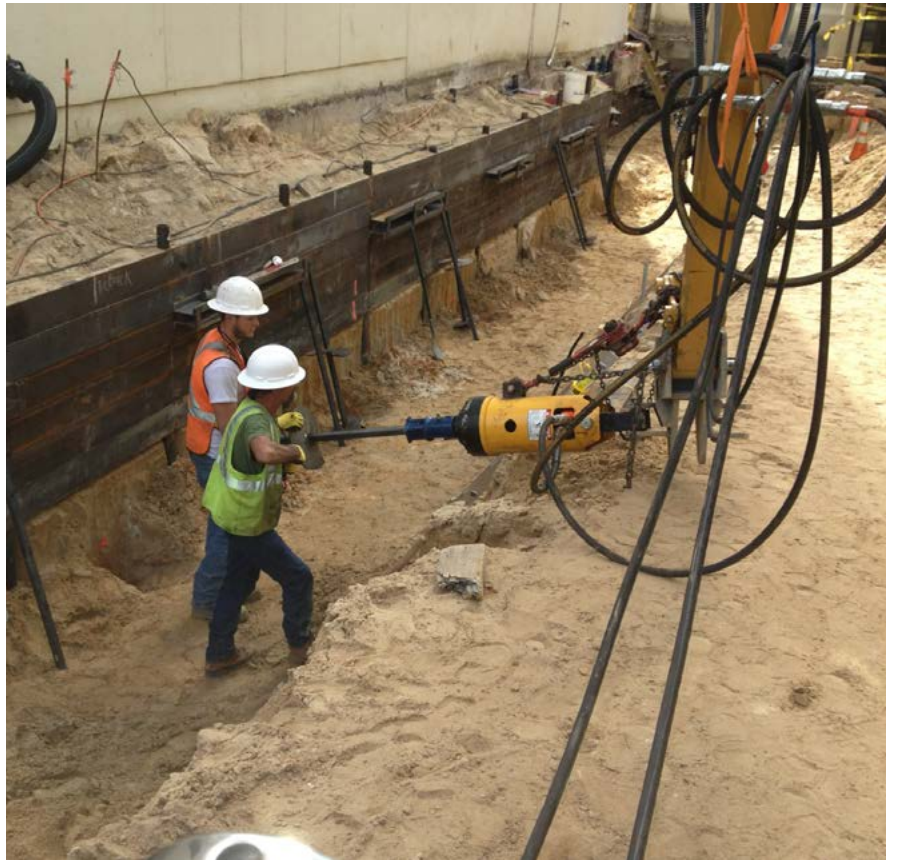

MAGNUM® Helical Soil Nails

Continuous Bonded Helical Anchors for Soil Reinforcement

Used in Earth Retention and Slope Stabilization

Description: As can be seen in the figure, soil nailing is the process of using helical shafts to reinforce slopes and blocks of soil for earth retention and stabilization. Helical soil nails have helical bearing plates spaced along the entire length of the shaft for continuous bonding with the soil. As opposed to grouted anchors which are generally 4 to 6 inches in diameter, helical soil nails mobilize a bonded diameter that is 8 or 10 inches in diameter for a greater reinforcing effect. Soil nailing permits the use of relatively thin shotcrete facing or steel mesh to prevent raveling between nails as opposed to the heavy reinforced facing required for soil anchor walls. Since helical soil nails are intended for earth reinforcement, the termination criteria for the anchors is based on length as opposed to minimum installation torque. Soil nail lengths then are fixed length (typically 0.7 to 0.8 times the slope/wall height). Fixed length allows for the shafts to be manufactured with an integrated thread bar adapter. There is no need to cut-off and re-drill the shaft. Helical soil nails have many advantages over traditional grouted soil nails. Installation is very rapid. There are no issues with caving soils and/or groundwater, and there is no waiting for grout to set.

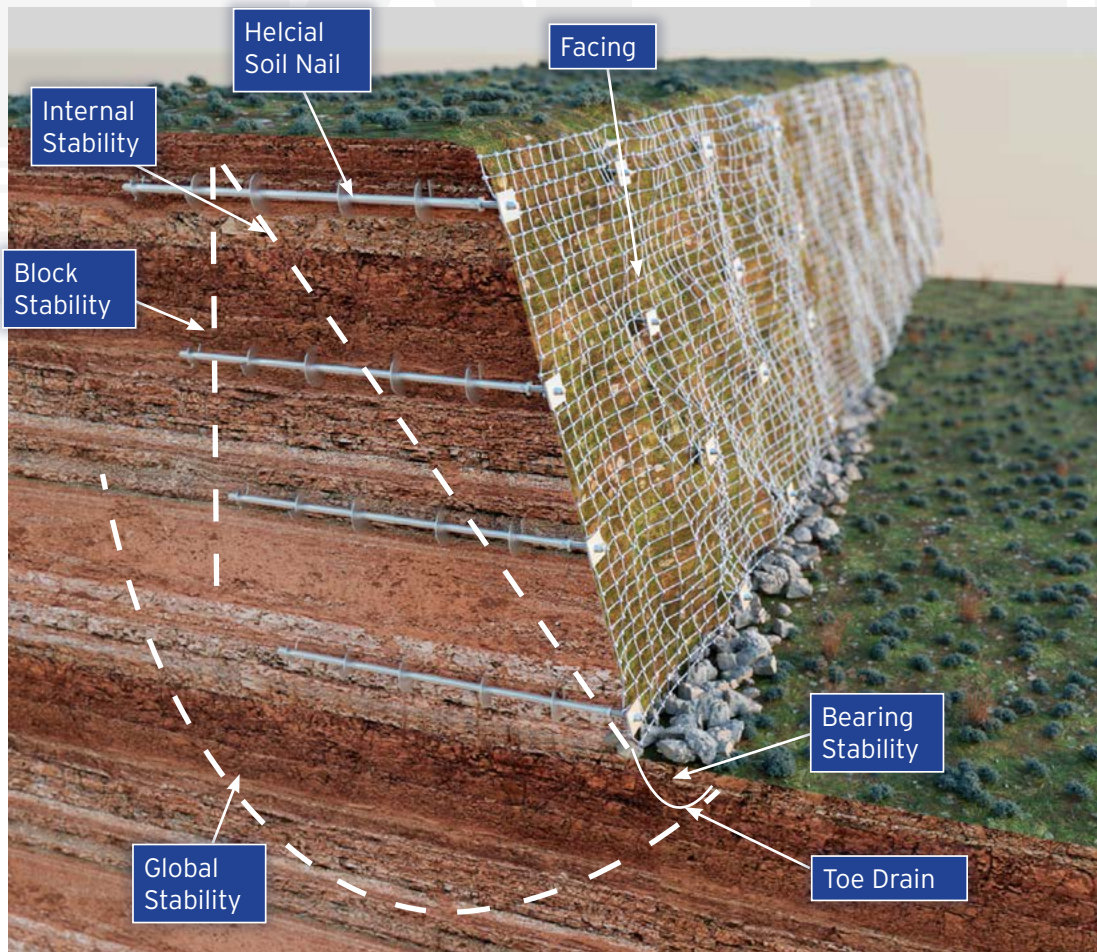

Designation	Shaft Diameter (in)	Helix Diameter (in)	Corroded Gross Area of Shaft (in ²)	Max. Allowable Tensile Strength (tons)	Max. Allowable Shear Strength (tons)
MHL313BN12K8D8D8D8D8DG	3	8	1.1	11	5
MHL313BN12K10D10D10D10D10DG	3	10	1.1	11	5

Note: Specification table provides two examples of helical soil nail sizes. Other lengths and sizes available.



156 Circle Freeway Dr.
Cincinnati, OH 45246
800-822-7437
www.MagnumPiering.com

MAGNUM® MDM6IS1224 Deadman Plate Anchor

16 Tons Ultimate, 8 Tons Allowable Capacity

12" x 24" x 0.125" Galvanized Plate Anchor
w/ #6 Gr. 75 Thread bar Anchor Rod

Description: The MAGNUM® MDM6IS1224 Deadman Plate Anchor consists of a 12" x 24" by 0.125" thick formed and reinforced steel plate with #6 Gr. 75 thread bar and can support working loads up to 8 tons in tension. The post is designed in accordance with IBC, ACI, and AISC codes. Design and detailing of the anchor varies by project and is the responsibility of the registered design professional including minimum length of thread bar, anchor spacing, and working load in ground.

Specifications	
Deadman Plate	12" x 24" x 1/8" Steel Plate ASTM A36 36 ksi or Better
Thread Bar	#6 Grade 75
Coating	Galvanized per ASTM A153/A123 (G), Standard MAGNUM® Blue Paint (P), or Epoxy Coated per ICC-ES AC228 (EP)

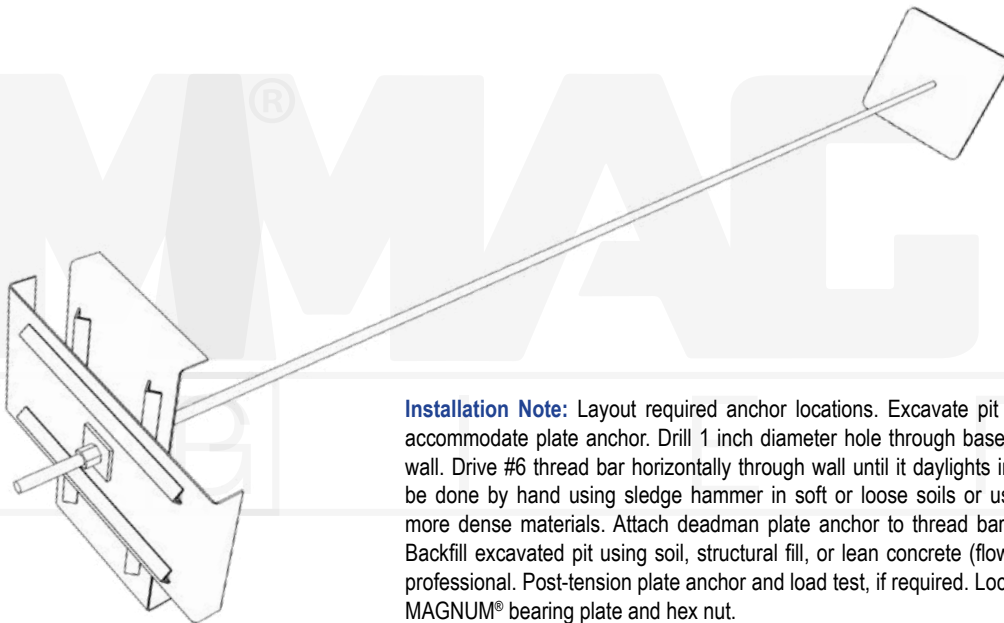
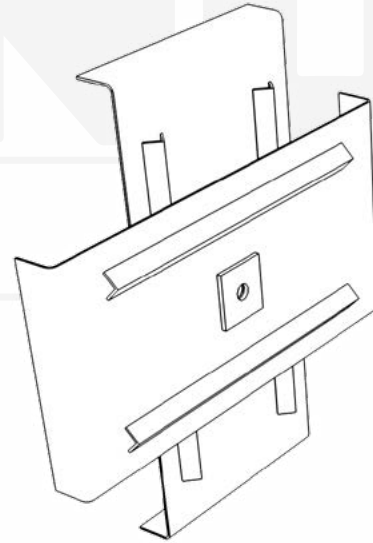

Installation Note: Layout required anchor locations. Excavate pit on exterior of basement to accommodate plate anchor. Drill 1 inch diameter hole through basement wall or other retaining wall. Drive #6 thread bar horizontally through wall until it daylights in excavated pit. Driving can be done by hand using sledge hammer in soft or loose soils or using a small jackhammer in more dense materials. Attach deadman plate anchor to thread bar using appropriate hex nut. Backfill excavated pit using soil, structural fill, or lean concrete (flow fill) as specified by design professional. Post-tension plate anchor and load test, if required. Lock off to basement wall using MAGNUM® bearing plate and hex nut.



Official Buy American Act Certificate

ATTENTION: Engineers, Architects, Building Officials, and Inspectors

SUBJECT: U.S.A Manufacturing

All Magnum Piering, Inc. products are manufactured in the United States. The raw materials used to produce our products are manufactured in various United States Steel Mills. All materials meet all provisions of the Buy American Act.

If you have any questions or need any further information, please do not hesitate to contact me.

Thank you,

A handwritten signature in black ink, appearing to read "Todd Paddock", with a stylized flourish at the end.

Todd Paddock
Vice President Manufacturing
Cell 513-617-6304
Office 513-759-3348 ext. 237
tpaddock@magnumpiering.com

MAGNUM Piering Inc.
156 Circle Freeway Drive
Cincinnati Ohio, 45246

www.magnumpiering.com
800-822-7437

Copyright (C) 2024 All Rights Reserved

Helical Piles

A Practical Guide To Design and Installation

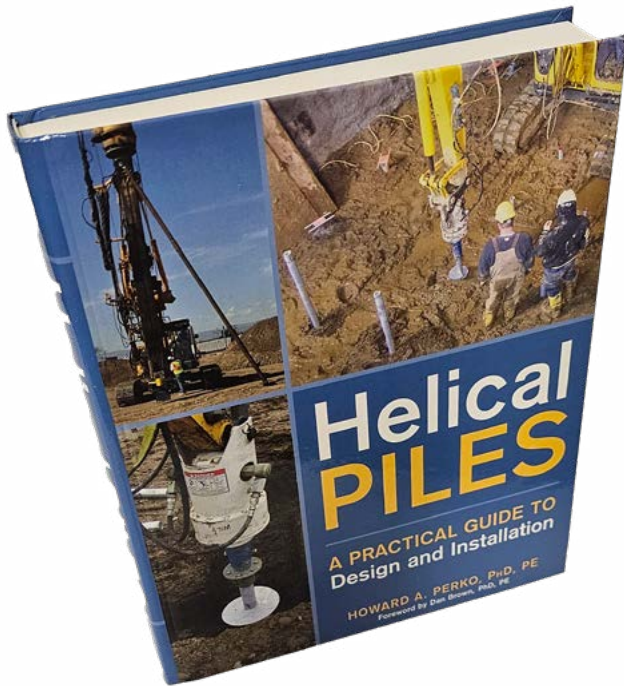

ISBN: 978-0-470-40479-9, Cloth,
528 pages, ~~\$125.00~~

MAGNUM® Group Discount

=

\$112/Book + Shipping

(Unique Offer: If desired, books ordered from
MAGNUM® may bear the authors' original signature and MAGNUM
PIERING® brand logo!)

 **WILEY**
Now you know.
wiley.com

Forward	Chapter 12 Foundation Systems
Preface	Chapter 13 Earth Retention Systems
Acknowledgements	Chapter 14 Underpinning Systems
Chapter 1 Introduction	Chapter 15 Economics
Chapter 2 Installation	Chapter 16 Proprietary Systems
Chapter 3 Basic Geotechnics	Chapter 17 Building Codes
Chapter 4 Bearing Capacity	Appendix A. Common Symbols and Abbreviations
Chapter 5 Pullout Capacity	Appendix B. Summary of Prior Art
Chapter 6 Capacity-to-Torque Ratio	Appendix C. Load Tests Results
Chapter 7 Axial Load Testing	Appendix D. Nomenclature
Chapter 8 Reliability and Sizing	Glossary of Terms
Chapter 9 Expansive Soil Resistance	Bibliography
Chapter 10 Lateral Load Resistance	Index
Chapter 11 Corrosion and Life Expectancy	

About the Author:

Howard A. Perko, Ph.D., P.E., Fort Collins, CO

- Director of Engineering, Magnum Geo-Solutions, LLC (The Engineering and Technical Support Company Associated with Magnum Piering, Inc.)
- Part-Time Academic Instructor, Colorado State University
- Chairman of Deep Foundation Institute: Helical Pile Committee
- Served on Operating Committee for CTL/Thompson, Inc
- Chair of 2007 DFI Annual Conference
- Founder and President of the Secure Engineering Companies

HOW TO ORDER

Call: 513-759-3348

And ask for Veronica Krouse
Please have your credit card ready

Please note, the special group discount is based on a total MAGNUM® order of 100 units. Send in your order right away in order to reserve your book(s) If you have questions, you are welcome to contact Sharon by e-mail at sappelman@magnumpiering.com; or CALL Toll Free 1-800-822-7437.

MAGNUM
PIERING
designed to support

Page - 293

Rev. 11-4-2025 | Copyright (C) 2016-2025 All Rights Reserved