

MAGNUM® MH3525U Helical Piles

42 Ton Ultimate - 21 Ton Allowable Capacity

High-Strength 3.50" Diameter, 0.254" Wall, Round-Shaft with Rigid Coupler

Description: MAGNUM® Helical Piles offer a number of unique advantages as shown below. MAGNUM® products are manufactured in the USA according to our ISO 9001 approved Quality Program. Our Helical Piles utilize rigid bolted couplings to join extension sections and the lead section, extending the helical bearing plates down to the desired bearing stratum. Structural Capacities are developed according to AISC 360 and ICC-AC308 considering buckling of 5 ft unbraced length after 75 years of corrosion in moderate to high aggressive soils. Various coatings, custom lengths and helix configurations are available upon request. See Magnum Technical Reference Manual for additional information.

1. Round shafts offer increased lateral and buckling resistance compared to square shafts.
2. Patented alternating helix pattern reduces wobble and improves plumbness and tracking.
3. 45-degree miter pilot point aids pile positioning and advancement.
4. Patented MAGNUM® Dual-Cutting Edge helical bearing plates (DCE) enhance penetration through dense soils with occasional cobbles and debris.
5. Sharpened edge on each helix slices through problem soils.
6. Conforming helix shape limits auguring and provides better quality assurance through valid capacity to torque correlations.

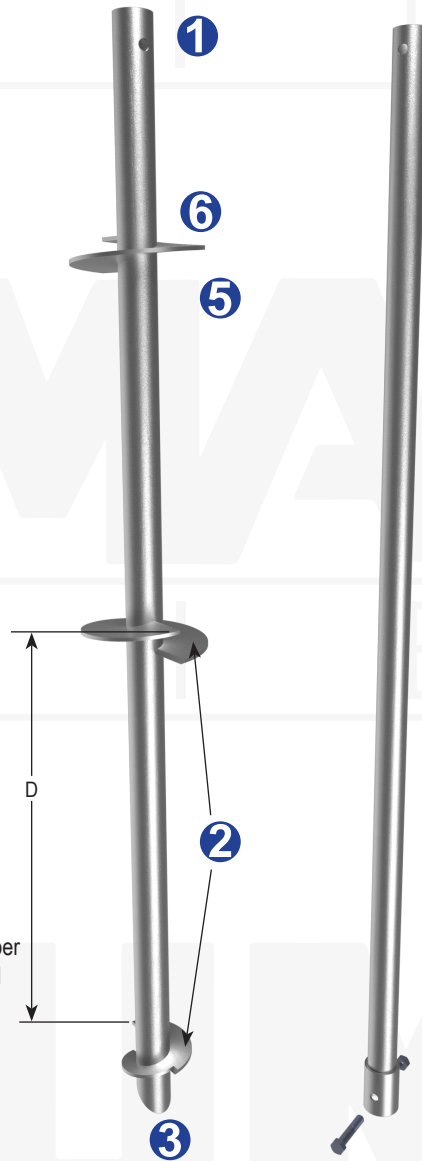

Drawing shows an example pile lead and extension section. Section lengths and number of helices vary with project requirements and soil conditions.

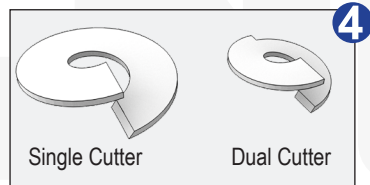

Specifications	
Shaft	3.5" x 0.254" Nominal Pipe ASTM A252, Fy = 80 ksi, or Better
Bolts	(1) 1" Diameter SAE J429 Grade 8 Zinc Coated to ASTM B695/F1941
Helices	3/8" Thick, Helix Die-Pressed ASTM A36, or Better 10", 12", 14", 16", 20 & 24" Diameters Available
Spacing 'D'	* 25-1/2" TYP
Pitch	3"
Coating	Galvanized (G), Bare Steel (NG), Epoxy Powder Coated (EP)
Properties	
7 ft ⁻¹	Ultimate Capacity-to-Torque Ratio
** 12,000f t-lbs	Maximum Installation Torque
Capacity by Torque	
42 Tons	Ultimate Capacity
21 Tons	Allowable Capacity
Structural Capacity	
*** 42 Tons	Ultimate Capacity
21 Tons	Allowable Capacity

Notes: Helical piles shall be installed to appropriate depth into suitable bearing stratum as determined by geotechnical engineer or local practice. Capacity by torque is based on advancing pile to maximum installation torque. A minimum factor of safety of 2.0 is recommended for determining allowable capacity from correlations with final installation torque. Deflections of 0.5" are typical at allowable capacity; a higher factor of safety may be required to achieve smaller deflections. For tension capacity, helical bearing plates must be deeply embedded (5 ~ 7 x ave. helix diameter or as specified by geotechnical engineer). Load tests are recommended when practical..

* Spacing = 34-1/2" with 20" & 24" Ø helices.

** Maximum Installation Torque rating considers Maximum Driving Stress per ASCE 20.

*** Structural capacity is shown for bare steel product after 75 years of corrosion. Structural capacity of galvanized product is more due to decrease in corrosion losses.



156 Circle Freeway Dr.
Cincinnati, OH 45246
800-822-7437

www.MagnumPiering.com